

**SOUVENIR**  
**NOTES**  
**BIBLE STUDENTS' CONVENTIONS**

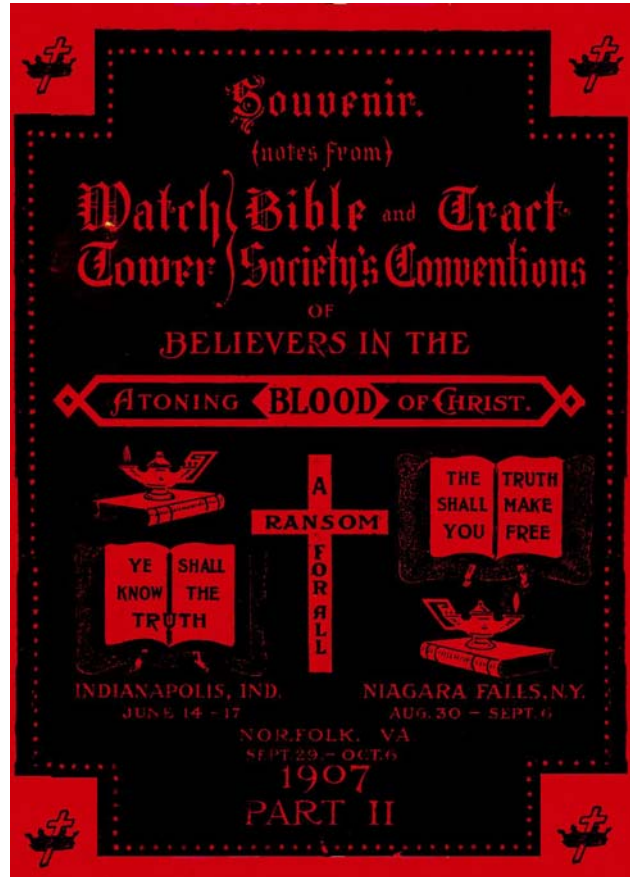

**1907**  
**PART II**

**SOUVENIR**  
**Notes from**  
**Watch Tower Bible and Tract Society's**  
**Conventions**

**INDIANAPOLIS, IND.**

JUNE 14-17

**NIAGARA FALLS, N. Y.**

AUGUST 30 - SEPTEMBER 5

**NORFOLK, VA**

SEPTEMBER 29 - OCTOBER 6

**1907**

**PART II**



# Souvenir



(Notes from)

## Watch Bible and Tract Tower Society's Conventions



ROCK OF AGES  
Other foundation can  
no man lay  
A RANSOM FOR ALL

To the King of Kings and Lord  
of Lords

IN THE INTEREST OF

HIS CONSECRATED SAINTS,

WAITING FOR THE ADOPTION.

THIS WORK IS DEDICATED

"To make all see what is the fellowship of the mystery which from the beginning of the world hath been hid in God." "Wherein he hath abounded towards us in all wisdom and prudence, having made known unto us the mystery of His will, according to His good pleasure which He hath purposed in Himself; that in the dispensation of the fullness of the times He might gather together in one all things, under Christ."

Eph. 3:4, 5, 9; 1:8-10.

INDIANAPOLIS, IND.  
JUNE 14 - 17

NIAGARA FALLS, N. Y.  
AUG. 30 - SEPT. 5

NORFOLK, VA.  
SEPT. 29 - OCT. 6

1907

PART II

## Are YOU?

Are you planning, dear friends, to the "Falls" you will go,  
Where the friends of the "blessed hope" meet,  
Where the Lord bath blessings in store for all, there  
A fellowship joyous and sweet?

What joy will be there at that meeting, with those  
Who are dressed in white robes like their Lord,  
When in heavenly places together they'll sit  
And drink in the bliss through Isis word.

Will it not be a glad and a joyous foretaste  
Of that glorious Convention so near,  
When all the dear Saints, the Lord's worthy Bride,  
Shall with Him in glory appear?

Yes! friends will be there with glad words of cheer  
From the North, South, West and the East,  
All gathered with one blessed object in view:  
To meet the dear Lord at the feast.

There, next the dear Lord, and in character like  
"That Servant" we all love to greet,  
Whom God in His wisdom hath set in the church  
To dispense in "due season the meat."

We will listen once more to His comforting words,  
So tender, so faithfully given,  
As He lovingly urges us on in the race  
For the crowns that await us in Heaven.

Then next come the Pilgrims, so dear to our hearts,  
We will listen with pleasure to them,  
As they tell us once more, the sweet story of old,  
How Christ Jesus died for all men.

We also shall meet, and the Colporteurs greet,  
The ambassadors for Christ and his crown,  
Who follow the Master in self-sacrifice  
And care not for earthly renown.

Prepare, then, dear friends, and don't miss the feast,  
Be there, let your presence be seen;  
Improve the precious time, the hour draweth nigh  
To reign with Christ nineteen fifteen.

R. B. M.

**BELIEVERS**  
IN THE  
ATONEMENT SACRIFICE OF CHRIST,  
"A RANSOM FOR ALL."

Dear Friends:

It gives us great pleasure to be able to send you Part IT of the report of this year's conventions, containing very full notes of nearly all the discourses and many of the testimonials of both conventions.

On account of the unusually large attendance, especially at Niagara Falls, where there were over 2,000 of "Like precious faith," it was found necessary to hold several overflow meetings, and as the discourses given at these overflow meetings were so grand and so full of such rich meat, we cannot refrain from reporting these also; although when sending out the announcements regarding the proposed reports of this year's conventions, we had no thought of there being extra meetings to report.

The force of Niagara Falls is now being used to generate electricity, which is being carried many miles and used as motive power, and illumination in other places.

All were set vibrating with the thrills of enthusiasm and interest generated at the Great Niagara Falls Convention.

The power generated by that mighty cataract of Truth and associated peoples of the Lord, doubtless will be used for illuminating and energizing purposes that will be far-reaching in effect. We know that of a surety a "great light" shown in that region for a time, with the Home of Shredded Wheat as the subsidiary power house, the main plant of which is Heaven itself.

May these Convention Reports (meat in due season from the Lord's table, dispensed by "that servant" and "the fellow servants") be, as it were, the "feed wires" to convey the current of love and blessings in every direction, to far off regions and all to the praise of our Heavenly Father, in the interest of His Truth and His dear ones.

It is with that hope, we are sending these out to the "household of faith," in the name of Him who is the giver of all good things, and who has promised to serve us at this time.

Yours in fellowship and service,

Geo. M. Huntsinger,  
Independence, Kans.

Dr. L. W. Jones,  
2024 Washington Boul., Chicago, Ill.

**NOTES**  
**ON THE SERMONS, INCIDENTS AND CIRCUMSTANCES CONNECTED WITH**  
**THE WATCH TOWER BIBLE AND TRACT SOCIETY'S**  
**CONVENTION**

*AT NIAGARA FALLS, N. Y., AUGUST 30- SEPTEMBER 5, 1907.*

Early in the summer, announcement was made that one of the General Conventions of this year would be held again at Niagara Falls. This was the signal for all to begin to make preparations to attend this convention, held in the same city and in the same building where so many met on a similar occasion two years ago. Accordingly friends from other places in the middle and western states joined with the Chicago Class and we were able to arrange for a special train, consisting of engine, baggage-car, four chair-cars and three sleeping-cars. Think of a special train entirely of Dawn readers! This train pulled out of Chicago August 29th with 270 on board. It is hardly necessary to say that we had a grand time en route, visiting one with another, singing hymns and distributing tracts. In due time, we reached Niagara Falls, N. Y., August 30th, and were met at the station by Brother Isaac Hoskins, one of the Committee from the Bible House. We then proceeded to find locations and get ready for the first session of the Convention, which was to open that afternoon.

While waiting for the Convention to open, it will not be amiss for us to describe the Home of Shredded Wheat and to mentally take a trip through their wonderful building and then view the great Niagara River with its rapids, falls, etc., and see what lessons we can draw therefrom.

## **The Natural Food Conservatory**

Buffalo Avenue between Fourth and Sixth Streets, Niagara Falls, New York.

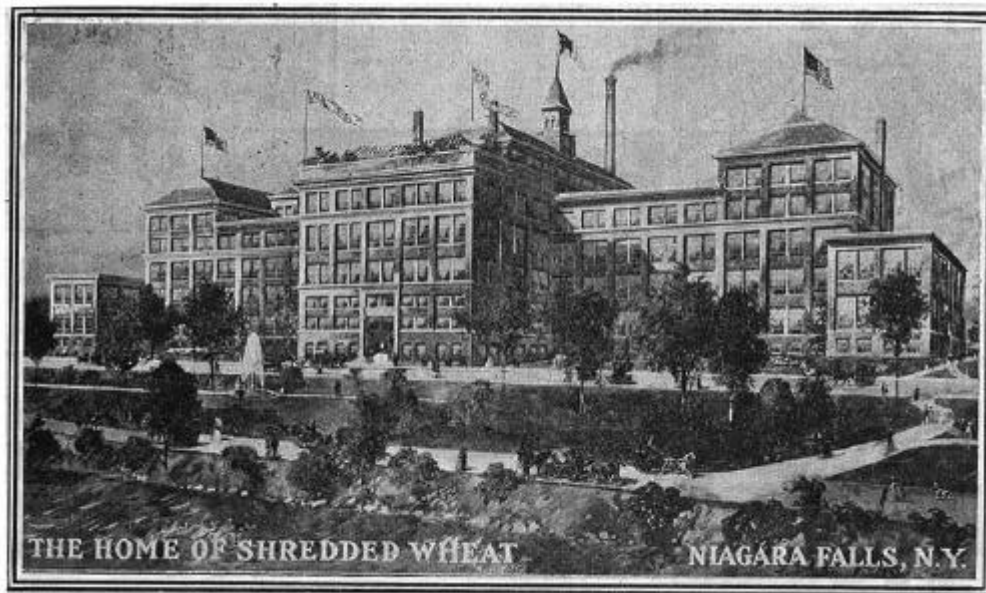

The Natural Food Conservatory

Buffalo Avenue between Fourth and Sixth Streets, Niagara Falls, New York.

In this wonderful building were the Convention Hall, Reception Parlor and other conveniences, which were turned over to us for the use of the Convention, FREE OF ALL CHARGES, by the NATURAL FOOD COMPANY.

### **The Home of Shredded Wheat**

The Home of Shredded Wheat -- the finest, largest and most hygienic building in the world devoted to food production, stands in the heart of the residence district of Niagara Falls, far away from the smoke and dust of factory and railroad, fronting the Rapids of Niagara River and within sound of the rush and roar of the great cataract.

This noble structure with the sunlight streaming in through thirty thousand lights of glass, flooding every nook and corner with cleansing rays, is dedicated to the scientific truth that a grain of wheat contains all of the elements of a complete and perfect food for man.

Here in this industrial palace of white tiling, marble and mosaics, visited every year by nearly one hundred thousand pilgrims to the Falls, are made every day over a million and a quarter Shredded Whole Wheat Biscuits.

Previous to visiting this institution, we had used some of their product, but not knowing how it was made or whether adulterated, we had formed no special liking for it. From 1500 to 2000

bushels of wheat are used every day in this work, nothing being taken from and nothing being added to the wheat. The grain is first carried to the top of the building to the cleaning room, where it passes through ingenious devices that remove from it every particle of dust, sand, chaff, rock, cockle and other foreign substances, dropping it clean into tanks of sterilized water. There are 20 of these machines, each doing its special work of cleaning.

The swelled and softened kernels are then spread on clean cloths and exposed to cool air for 14 hours, being turned from time to time with paddles until ready to feed into the hoppers for the great shredding machines, each 80 feet long, and consisting of 36 pairs of corrugated rollers. The wheat kernels are caught between these rollers and drawn out into fine porous shreds, laying layer upon layer, until the thickness of a biscuit is formed, when the long band of white filaments is brought into a cutting device which separates them into oblong cakes, and drops them into pans holding 48 biscuits each. The pan is then placed in the arms of a large drum, shaped like a Ferris wheel, which revolves in an immense oven, until the biscuits are baked brown, but they are still damp inside, so are passed through a second long oven. They move slowly and it requires about three hours for them to pass through the long oven, but when they come out they are thoroughly dry, and then they go to the packing table, where they are put into boxes by girls, and this is the only time in the whole process that the biscuits are touched by the hands of anyone. After seeing such a process and realizing what that is, many of us began at once to incorporate Shredded Whole Wheat Biscuits in our diet. Purity and Cleanliness seem to be the watchwords of the Natural Food Co.

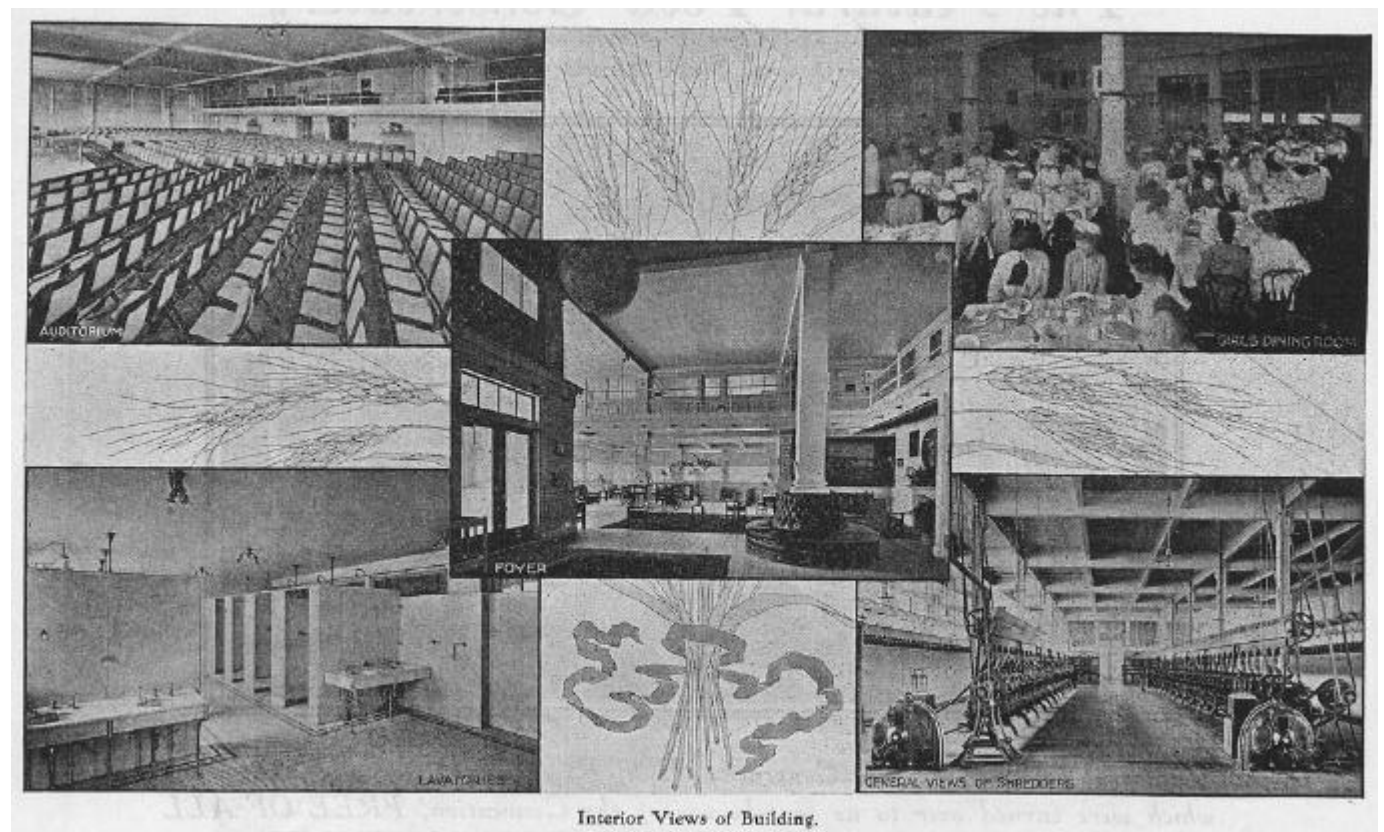



Let us go back to the Home of Shredded Wheat: We refer to this building and the work done in it, at considerable length, because we think we see in it foreshadowings of restitution blessings, both in the product and in the manner of treating the employees; also because Shredded Wheat is a food which possibly the Lord is permitting to be brought to our attention at the present time because of its economical as well as healthful qualities. Being of the whole wheat, it is a perfect food, as the whole grain of wheat contains all the constituents necessary to the sustenance of the human organism. Three shredded wheat biscuits will make a substantial meal for a workman, and in view of the approaching experiences of trouble upon all classes such an item of economy in food seems to savor something of the providential for the Lord's people, who are none of them blessed with an abundance of this world's goods, and they may have to endure considerable physical privations before the "great time of trouble" comes as the special testing for the world.

The more you know about the plant and the process, the better you will like the Shredded wheat products. Why does the Natural Food Co. keep "open house" for the thousands of visitors to Niagara Falls? Because nearly everyone who visits this model plant and notes its spotless cleanliness and the scrupulous care with which the purity and healthfulness are guarded, becomes a consumer of Shredded Whole Wheat Biscuit. He gets the "Shredded Wheat Habit." An industrial building that is visited by so many thousand people every year is worth knowing something about, and we are glad to in a measure reciprocate the kindness of the Company to the Convention in general, by incorporating some facts concerning them in this report.

Certain factory ideals have been attained in this building which make it unique among the industrial plants of the world. Mere figures give a very inadequate idea of the noble proportions of this building. They do not tell the story of the architectural symmetry, its costly equipment or its perfect adaptation to the work of making the cleanest and most healthful food product on earth. Those who like figures, however, will be interested in knowing that the Natural Food Conservatory is 463 feet in length, by 66 feet in depth, contains 3,000 tons of steel and 200 tons of marble. Its beauty is greatly enhanced by the 844 windows, with their 30,000 lights of glass, making it indeed a veritable "crystal palace."

The building is entered through a large foyer, on either side of which are writing and reading rooms for guests, furnished with beautiful rugs and sumptuous weathered-oak, leather-upholstered furniture. From the middle of the ceiling hangs a pendant, a great crystal ball, inside of which are 36 electric lights. At the base of the vast columns supporting the ceiling are upholstered settees.

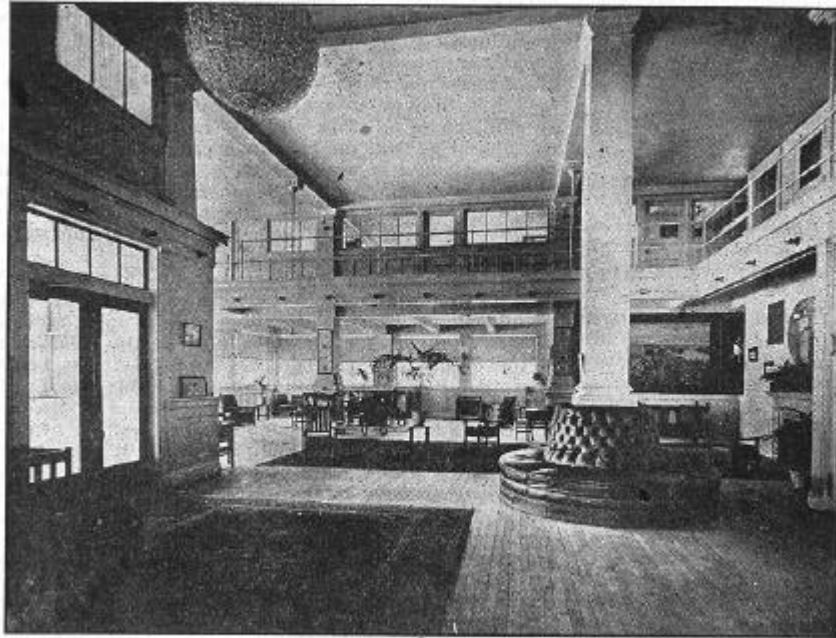

Foyer, or Reception Hall.

It was in this splendid reception room that the friends met between services for social greetings, writing letters and postals to the dear ones at home, etc. In this room were located the desk of the Secretary of the convention and the Information Bureau. We also held some of the overflow meetings in this room. It will long be remembered by the friends who were permitted to enjoy its comforts and blessings.

In one end of the foyer dainty "demonstration lunches" are served to visitors, and here may be found guides to pilot visitors through the building. The gallery around the foyer, as well as the floor above, are taken up with administration, publicity and accounting offices.

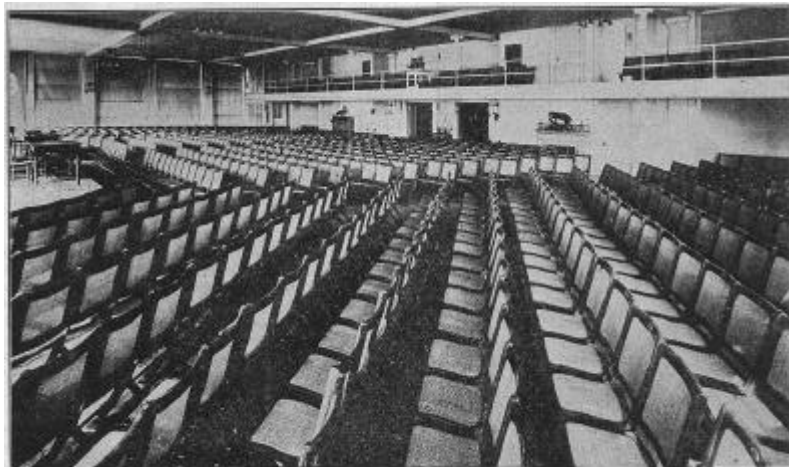

The Great Auditorium, Seating over a Thousand.

On the fourth floor is a convention hall or auditorium, with a seating capacity of 1,080. As no public services were to be held, it was expected this auditorium would be ample. The friends, however, evidently knew where the Pure Food was to be dispensed and they flocked there from

all parts of the country, so that soon we numbered over 2,000. The International Opera House was then secured for some of the sessions. That holds about 1,900, but it too was found inadequate, so that while meetings were in session there, overflow meetings were held in the auditorium of the Pure Food Co. There were from four to six hundred at these overflow meetings.

The building is electric lighted throughout, and has all modern conveniences in keeping with the other handsome appointments. There are elaborate lavatories and bath rooms finished in marble and mosaics at a cost of \$100,000.00, these are provided with not only hot and cold water, but with needle and shower baths. These are for the use of all of the employees of the company and they are furnished with soap, towels, etc., free of charge. Also they are given one hour a week, with pay, for bathing purposes, and are permitted to take other baths before and after working hours and at the noon hour if they wish. The woodwork of the entire building is of white enamel and is kept immaculately clean. The windows are double glazed making them dust proof. The pure air, filtered through sieves, is forced through the structure by means of great suction fans and ventilator shafts. It would require a good sized booklet to describe the many departments of "welfare work" carried on by this company to guard the health of their employees and to secure their comfort, contentment and intellectual and moral improvement. The company not only provides a locker for each employee, costly lavatories and baths, and hygienic noonday lunches, but maintains a circulating library, and gives them access to hundreds of other periodicals. It provides addresses by men and women of note, classes in English composition, essay contests, cooking school, sewing school, boys' vegetable gardens with cash prizes for the best work and children's playgrounds. It furnishes the girls in the manufacturing section with caps, aprons and sleeves free, and they are also provided with chairs which have foot and back rests. They are allowed fifteen minutes morning and afternoon for rest and recreation.

The company gets its power from Niagara Falls. The "harnessing" of this mighty Cataract to the wheels of industry was made possible by the electrical power transmission. It is this great engineering triumph which makes the Natural Food Conservatory a bee-hive of industry by day and a palace of electric beauty by night. Thus the most wonderful achievement of modern electrical science is yoked to the greatest of dietetic science. Nature's greatest wonder is providing the world with Nature's greatest food product, and here was held the best and largest convention of Pure Food Bible Students the world has ever known.

### **A Trip to the Falls.**

As the Convention was not to open until afternoon, Saturday, some of the friends went to see the wonderful Niagara Falls.

Walking about a block through the Natural Food Co.'s Park, we arrived at the shore of Niagara River, about a mile above the Falls. Here the water is calm, without any suspicion of the disturbance further on, except for the roar that could be heard even up there, and for a faint view of the Rapids in the distance. From this point in front of the Natural Food Co.'s Conservatory, to

the Falls themselves along the American side of the river is the Government Park, kept in the nicest kind of order by the Government, and which offered a most delightful walk while viewing the Rapids and Falls. In this Park is the lagoon, an old mill race, running beside the Niagara River; it was in this lagoon that the friends were immersed. The entire view must be seen again and again to be appreciated.

The fall of the Niagara River from the head of the Rapids, three-quarters of a mile above the Cataract, to the edge of the precipice is nearly 60 feet, the velocity of the current varying from seven to twenty-seven miles an hour. No words can describe the grandeur of this sight to the visitor as he stands upon the brink of the current above the Falls and looks out across the tossing, foaming stretch of water, a very emblem of chaos itself. All the shades of green and violet are displayed in the colorings of the water, while spread over it, like a network of filmy lace that rises and falls with the tumultuous heaving of the water's bosom, is the white foam and spray and mist. A walk of about three-quarters of a mile along the edge of these grand, sublime, yet awful Rapids, brings us to the Falls themselves.

The American and Canadian Falls are divided by Goat Island, which is reached from the American side only, and is connected with the mainland by a beautiful stone bridge, which takes the place of several crude wooden structures that served as passageways the past three-quarters of a century. Many have wondered how a bridge could be built across these awful Rapids. The piers were formed first by building a massive abutment of timber on the water's edge, from which were projected enormously long and heavy beams of timber. These were secured by great piles of stone, and their outer ends rendered steady by stilts thrust into the bottom of the river. A platform was then built, loaded with stone and then sunk and on this a pier was built.

No view of the Fall is so terrifying as that of standing on Prospect Point, a jutting rock which is perched on the very brink of the American Fall. The majesty and overwhelming grandeur of the sight from this spot can never be forgotten by those who have witnessed it. Not five feet away is the very brink of the Fall, over which the waters pour in resistless might. The whole sweep of the cataract's brink is visible from this point. The line of the precipice over which the waters sweep is jagged and irregular, and causes the spray to dash out in great spurts, as though some titanic hand were tossing the water from hidden depths. Here and there where the rocks come near the surface, their ebony outlines can be seen beneath the crystal whiteness of the flood. There has never been an accident at this point, though the entire Falls are said to claim about 50 victims each year. More than one mortal (not immortal) tired of life or fascinated by the sight, has sought death by leaping into the flood. A stout railing encircles Prospect Point, which is part of Prospect Park, a beautiful spot containing about ten acres.

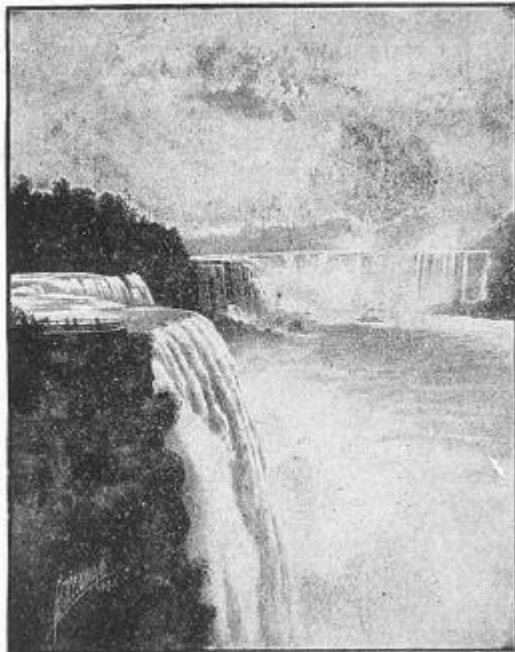

Prospect Point.

It is estimated that 275,000 cubic feet of water pass over these Falls every second. The present height of the American Falls is 161 feet, while the Canadian side is 158, a discrepancy which is caused by the slope of the land. For three-quarters of a mile above the Falls, the River drops 60 feet, the Falls themselves about 160 feet, while the River at the foot of the Falls is 180 feet deep, making a total depth from the beginning of the rapids to the bottom of the river of 300 feet.

Below the Falls, the water is again calm and quiet for about two miles, when we come to the Lower Rapids. At this point the river is not more than 100 yards wide, and through this narrow defile, the united waters of Lakes Superior, Michigan, St. Clair, Huron and Erie go thundering by at the estimated speed of twenty-seven miles an hour. The roar is deafening. The force of the water is like the rage of some imprisoned Titan, who, struggling beneath the flood, tosses the water in snowy spray and angry billows from 20 to 30 feet above the head of the spectator standing securely upon the shore. It is estimated that fifteen hundred million cubic feet of water rush through the Whirlpool Rapids every minute. The depth of the water here is problematic; it is supposed to be about 300 feet.

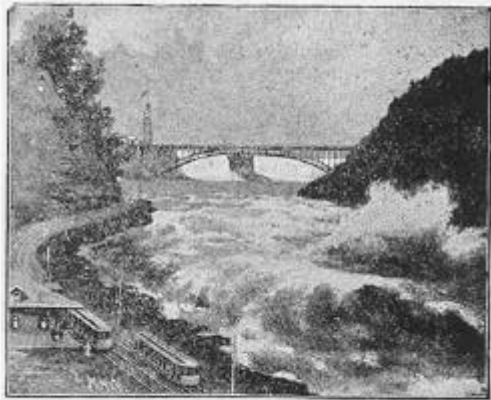

Lower Rapids.

The Whirlpool is about a mile below the Rapids. The popular conception of it is that of a maelstrom, a vortex of water swirling in gradual narrowing circles to a depressed center. Instead of this, the force of the water pouring into the basin raises it in the middle to a distance of three feet above the outer surface. The Whirlpool is the natural result of the mighty body of water rushing into a confined space, seeking an outlet. Bodies, driftwood and everything that finds its way into the Whirlpool circles around for days, and perhaps is never gotten out. Below this Whirlpool, the water is again calm and flows on through a beautiful country with rich farms and orchards.

## **Niagara River as Illustrative of God's Great Plan.**

This whole picture, from beginning to end, presented to the truth people a picture of the Plan of the Ages. First, the mighty Niagara River, so full of wonderful grandeur and beauty, from a natural standpoint, always inspires us with a better conception of God's Almighty power manifested in His vast creative works. The broad, limpid reaches of the upper river, the rushing rapids, the wonderful cataract tumbling in awful splendor over the mighty precipice, the foaming, lashing, leaping, angry waters of the whirlpool rapids, the sinister swirl of the whirlpool itself, and the final exulting dash of the raging waters as they race down the lower gorge to the freedom of the lake beyond, all inspire us with a solemn appreciation of divine power and the comparative insignificance of human capability alongside these marvelous works of nature. They impress us, too, with a realization that not blind chance nor things haphazard are responsible for the mighty forces of nature, but omnipotent power and authority designed the whole scheme of creation, and these giant wonders are but evidences of God's glorious handiwork.

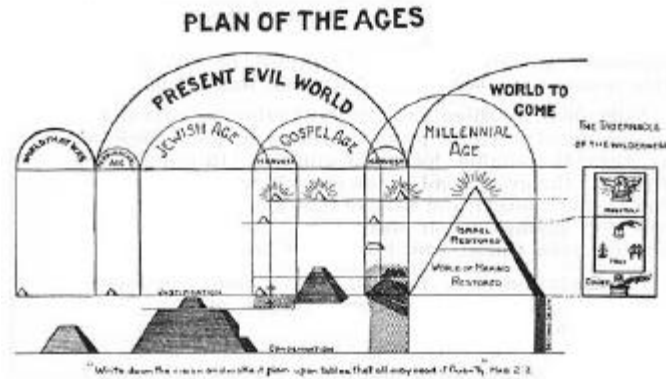

However, it is as we come to look at Niagara River as illustrative of some of the precious features of our Heavenly Father's Plan of the Ages that we see a more remarkable reason for regarding it as God's design. From this standpoint we see how almost every feature of it presents to our view an element of God's great purpose for the ultimate blessing of mankind. If we take the river as representing the course of the human race since the creation of the first pair in the Garden of Eden, then the head waters in Lake Erie would represent God's infiniteness -- without beginning, grand, sublime, incomprehensible. The river shows the course mankind has taken during six thousand years of experience -- winding, twisting, deviating here and there, but always confined by its banks, which represent God's permission, allowing the world certain liberties, but not permitting it to violate His own arrangements in any respect. The world has been pursuing its own way thus limited for sixty centuries, and now the Lord intimates that it must suffer an experience of extreme discipline, that it may learn the exceeding sinfulness of sin to the full -- that it may have so severe a lesson that it will never again be necessary to repeat it. So divine wisdom will permit a "time of trouble such as never was since there was a nation -- no, nor ever shall be." We see the beginnings of it already in the threatenings of capital and labor, in the unrest which pervades the whole social, financial, political, educational and religious world. These "elements," inspired by selfishness, will ultimately "melt with fervent heat" in the friction produced by their own opposition. This is illustrated by the rapids above the Falls. Before the water reaches the mighty precipice it is lashed into frenzy by a series of jagged boulders and rocks over which it flows; then, separated into two streams by Goat Island, the water finally plunges with terrible roar and fury into the awful chasm below. In the midst of the present stress and trouble which we see manifest among the nations, stubborn selfishness, so fitly represented by "Goat" Island, will cause the great cleavage between Capital and Labor, which stand for the great interests of the world today, and the result will be the great cataclysm, the "time of trouble," the day of the Lord's wrath upon all mankind, when present institutions will be disrupted and disorganized and the kingdoms of this world shall be dashed in pieces as a potter's vessel to give place to the Kingdom of our Lord and His Christ.

On the American side of the river, one hundred feet from the bank and parallel with the rapids above the Falls, is a series of upright rocks which form a channel, conducting the water of the river to a narrow lagoon further down. This lagoon passes between Willow Island and the mainland and is about thirty feet wide. The water is very placid, quite in contrast with the rapids on the farther side of the island. These features would appropriately represent the opportunities of the Gospel Age -- the upper channel illustrating those who are justified and "called;" the narrow lagoon indicating the way of self-sacrifice open to those who are willing to give up self

and walk in the footsteps of the Redeemer. These are separated from the world and its turmoil and stress and trouble by divine providence and care (represented by the beautiful little island), though they can hear and appreciate the sounds of trouble which are manifest on every hand. The waters of the lagoon empty into a placid little lake below, which would fitly represent the gathering of the faithful members of the church into the privileges of the Kingdom, whence they will be able to bestow blessing upon all the world during the Millennial Age.

Below the Falls the river surface becomes smooth and gentle, suggesting the opportunities of the Millennial Age, when the inhabitants of the world will learn righteousness, and when "nothing shall hurt nor destroy nor offend in all of God's holy kingdom." This condition will last until the close of the Millennial Age, when Satan will be loosed a little season for the testing of the whole human race. This testing is represented in the awful grandeur of the whirlpool rapids. The testing will be exceedingly severe, for upon the result of it will depend the future opportunities of eternal life for the race. Those who fail -- who are deceived by the Adversary -- will suffer the Second Death, represented in the Whirlpool. The "smoke of their torment will ascend forever and ever" -- that is, the lesson of their disobedience and its result will be a reminder to the rest of the world of God's unchangeable attitude toward sin -- "The wages of sin is death." This is pictured in the lower rapids, which ultimately give place to the broad sweep of the river as it hastens on to the haven of the lake beyond. After the Millennial Age has accomplished its work for the blessing of mankind there will be opened up new opportunities in the "ages to come," merging into the grand infiniteness of eternity, when blessing and peace and joy shall be without end.



## FRIDAY, AUGUST 30

*Brother J. E. Anger, of Niagara Falls, N.Y. called the Convention to order at 2:30 P.M., and after the singing of Hymn No. 23, and prayer by Pilgrim Brother John Harrison, made the following opening address.*

Dear Brothers and Sisters in Christ: Interested visitors to this Bible Students' convention in behalf of our little class of truth-seekers and the people of the city of Niagara Falls, it has fallen to my lot to extend a hearty welcome to each of you to our city, and this convention. You have come from the east, the west, the north and the south, many of you hundreds of miles to this, the greatest of American meccas -- not as a majority of Niagara's pilgrims do, to admire the beauties and stand in awe before the power, grandeur and sublimity of one of the greatest of Nature's handiworks -- the great Falls of Niagara, that draws its votaries from the uttermost parts of the earth, but to meet with Him, who, when He was upon the earth, was meek and lowly of spirit, who learned obedience, who completed that part of His work then due, was highly exalted to the divine nature, who is soon to return in great power and glory as the Lord of Lords and King of Kings, to rule on the earth in order to dethrone the arch enemy of mankind, to liberate the captives of death and to distribute the Abrahamic blessings to all the families that ever lived upon the earth.

We know that this great Personage is present, for He said that "wherever two or three are gathered in my name, there am I in the midst of them." We have several hundreds more than the required number here assembled in His name, as all can see by the happy expression upon the faces of those before and about me; therefore we welcome you to Niagara Falls, and introduce you to one you already love, and serve -- the Lord Jesus Christ, the Lord of Lords and King of Kings, our Redeemer and Elder Brother, who will rule over this convention through His appointed servants, and we invite you all to sit at the Master's feet, as Mary did, and drink in the truths of His wondrous plan and love until your hearts overflow with gratitude and love to God for all His goodness to us, and manifest that love and gratitude in a flow of brotherly kindness throughout this special gathering of God's dear children, that casual or interested visitors will be constrained to say, "Surely this people have been with Jesus and learned of Him."

Now, dear brothers and sisters, having welcomed you to our noted city, we place ourselves at your disposal, as regards reliable local information, introduce you afresh to the great head of the church, we now introduce you to one another and believe that you will prove to be true the saying of our dear Lord, "that one is your master, even Christ, and all ye are brethren."

In conclusion, dear friends, I have great pleasure in introducing to you the representative of the Watch Tower, Bible and Tract Society of Allegheny, Pa., who will be the permanent chairman of this convention; one whom most of you know and love --- our beloved brother, F. W. Williamson.



## **Response by Brother F. W. Williamson.**

Dear Friends: I do not think that you are able to realize how much my heart is overflowing this afternoon. I think you have some conception, but it is only a small measure. You recognize the love of God springing up in your own hearts, and I, dear friends, reciprocate and respond to that blessed, that precious feeling.

The words that come to my mind this afternoon as I stand before you are the words that our dear Brother Russell left with us two years ago as we closed the blessed convention that was held on that occasion. You remember how, standing on this platform, as we were wending our way about and saying good bye to the dear ones, he gave to us a convention number. Do you remember it? It has been ringing in my ears, I think, ever since: Number 62426 -- Numbers the 6th chapter, 24-26 verses. You remember Brother Russell gave it to us in the number form and we were to find out for ourselves what it was, and how we all went home that night and looked up the words he left to us, and they were the words of blessing: "The Lord bless thee, and keep thee; the Lord make His face to shine upon thee, and be gracious unto thee: The Lord lift up His countenance upon thee, and give thee peace."

This afternoon as we come together again, dear friends, it is with that same message -- "The Lord bless thee and keep thee." We want to make that a personal message this afternoon, and make it the message of this whole convention, praying that the Lord's blessing -- and how much that means! -- may be upon every heart, upon every mind, and upon all of the thoughts that shall be expressed in words, not only upon this platform but in our conversations and associations together in the convention greetings and meetings, and also in our associations with those whom we shall meet in the homes where we are staying. May this be the most blessed convention that we have ever enjoyed. It should be the most blessed convention. If it is not the most blessed convention we have ever had, then it is because we have not been growing in the Lord's wisdom and grace and love as we ought to have been growing. There ought to be more of a blessing, proportionate to the numbers who are here, than ever before. Truly we are a larger number than has ever before gathered at our conventions, but that should not be the only reason why it should be the most blessed convention, but because the Lord's love and His wisdom, and the fruits of the Holy Spirit, should be so accumulating in our hearts, and manifesting themselves in our lives, that we cannot help but have the most blessed, the most joyous, the most upbuilding, convention that we have ever had. So may this be the keynote of our convention -- that we shall have the best in our hearts, and the best manifesting itself forth to others.

Now, dear friends, there are a great many things we could talk about in connection with the opening of the convention, but there are just a few points I want to call to your attention, particularly that we may remind ourselves of the responsibilities as well as the privileges which are enjoined upon us in connection with this glorious gathering.

We have come together with the thought of the blessings which we shall get. We have been thinking about it, we have been planning for it, we have been praying for it, we have been looking forward earnestly to the day when this Niagara Falls Convention of 1907 should begin, and we have been thinking of all that we were going to receive and of all the blessed influences that should come to us to stimulate us and strengthen our love and our faith, and to help us to be

better servants of the Lord than we have ever been before. But have we been thinking sufficiently about what we are going to give? Now that is what we want to consider. We have been thinking about what we shall get and of the glorious things that we should receive at the convention. While we are thinking of the things we should receive, let us also remember that it is more blessed to give than to receive. So, let us, then, as we are meeting with one another, and as we are going about throughout this city, evidence the fact that we are the children of the Lord; let us see to it that there is a spirit manifest to others which will enable them to rightly recognize that we have been with Jesus, that we have learned of Him, that His Spirit is dwelling in our hearts, so they, taking knowledge of what we are doing, what we are saying, what we are manifesting, shall say to themselves, "That is a child of God." Thus they will be stimulated to come to a closer appreciation of God's love and an earnest desire to follow in His ways, and all of those who have honest hearts and are really seeking for righteousness, seeking for God if haply they may find Him, will receive the blessing that the Lord intends they shall receive from our testimony. So let us see to it that that shall be our attitude of heart throughout these precious days of our association here together. In the homes in which we are located let us remember this particularly, so that those with whom we are associated there shall recognize the Lord's spirit in us. Perhaps we may not find in these homes all that we might have expected; perhaps there have been some difficulties that have come to us in connection with our locations, some things that are not altogether desirable, but let us remember that the earthly things, the temporal things, are not the chief considerations; that these things are but for a moment and they are not worthy of comparison with the precious things we expect to get in our fellowship and association together. Let us lay these things aside; let us accept some of the little annoyances, and the little inconveniences, for the sake of the development of the characterlikeness of the Lord that it may accomplish in our hearts, because these experiences the Lord permits to us are just for the purpose of developing His Spirit and that we may have more and more of patience, more and more of self-control, and more and more of love, that others may recognize that even under adverse conditions, we are ready to accept whatever the Lord permits for us and to rejoice in these things as permitted of Him for our blessings and for our upbuilding in Christ Jesus.

Now, dear friends, in opening this Convention, in realizing all of the blessings that the Lord has given to us in the past in connection with these precious associations together, let us continue to consider His precious love to us as His children. May we be enabled to realize more particularly than we ever did before how gloriously we are the recipients of His grace, that nothing we have received is because of any merit of our own, but it is all from the abundant merit of Jesus Christ, our Lord and Master. May He help us to realize the glorious condescension of our Heavenly Father in giving to us such precious privileges of association together, and, rejoicing in all of this, may the opportunity which is now presented to us stimulate our courage, strengthen our zeal, and help us to be more and more filled with faith in all that the Lord has given to us, so that in His due time, having finished our course with joy, we shall receive an abundant entrance into the grand convention beyond the vale.

These little conventions we now have are but the foretaste of the glorious one that is to come. We know that the spirit which is manifested in these conventions is the same kind of spirit that will be manifest there. It is such a spirit of joy, of blessing, of peace that fills all who come together in these associations that it necessarily brings to our mind the joy, and the peace, and the

love, and the favor, that shall be gloriously manifest when we have all come together in the precious privileges which shall be ours in the kingdom.

So let us keep this in mind; let us constantly remember that we are children of the King, and rejoicing in all that the Lord has given to us out of His loving favor; and let us be faithful even unto death.

Our thanks this afternoon are specially due to the Niagara Falls class, who have welcomed us through the words of our dear Brother Anger. We love the class here, and rejoice in the precious fellowship we shall have with these dear friends. It is a small class that is here, but we rejoice to know that they are full of love and zeal. We rejoice in the expressions that have been given to us by our dear Brother Anger.

I think this afternoon, we have special reasons to thank the Lord for the special opportunities we have in connection with this building. It is the Lord who provided it for us, even though He is allowing some other people to use it for some other purpose also at this time. We thank the Lord for the privilege we have of gathering together in this beautiful place, and for all the conveniences which are provided for our comfort, and incidentally, too, and with exceeding fervency, we thank the ones who have charge of this building and have allowed us to use it for the purpose for which we are gathered this afternoon and for the coming week.

Now, dear friends, we have opened the convention; it is now ours. It is not my convention. It is not the Watch Tower Bible and Tract Society's convention in the sense that it belongs to the society, but it is your convention; it is our convention. So let us enter into the spirit of the convention in the way the Lord would have us do. We shall use the rest of this service for the purpose of allowing the dear ones gathered here an opportunity of manifesting by the spoken word the joy they have in coming together.

After the singing of Hymn No. 42, there were a number of testimonies given, part of which appear following, but in most instances we are compelled to give only the substance or central thought of the testimony, and as we could not always get the names of the dear friends accurately, it is thought best to omit the names in most instances, and simply say, "A brother" or "A sister," as the case may be.

Pilgrim Brother Harrison gave the first testimony, which was as follows: "My heart is rejoiced in this privilege, in my pilgrim way, to be permitted to stop for a few days at this convention. I have been looking forward to it with anticipation, and I shall be greatly disappointed if my heart is not greatly refreshed by these services. Indeed, I have been greatly encouraged, and cheered, since coming in this morning, and I know that we are all in sweet and glorious anticipation of a joyous season of refreshment, and waiting before the Lord, and in our greetings one with another in this earthly pilgrim way -- for we are all pilgrims, we are all strangers, we are all sojourners; our citizenship is not here, it is in heaven. Let it be true to the end of the race, until it shall be said to each of us, "Well done, good and faithful servant, enter thou into the joy of thy Lord."

A Brother: I do not think anyone is happier than I at this convention, and that is the reason I am going to jump up right away and tell you so. I came this morning and met a lot of friends I had

not seen for a long time, and my heart was so filled with love and joy that it was as much as I could do to contain myself, and I dare say that everybody else felt as I did.

A Brother: Sometime ago I had almost given up all hopes of coming to this convention because my means ran down too low; but God in His love and mercy and foresight gave me more than sufficient and now I am thankful, and praise God with all my heart.

A Sister: If anyone had told me a year ago that I would go so far away from home to attend a convention, I would have said, impossible. But what will not Present Truth make one do! I rejoice in Present Truth, and I am growing day by day. Why, I live on it. I am alone in the world, but yet I am not alone; it is Jesus and I.

Brother Williamson: Someone has said that one with the Lord is a majority. So, dear sister, you are not alone when you have the Lord with you.

I find that some of the dear ones here are making a great mistake: they think that it is Brother Williamson who is on this platform. I am not Brother Williamson; I am Brother Fred. Brother Williamson is not able to be at this convention, dear friends, much to his regret, and much to our regret, but I am glad that I have the privilege of being here. I hope none of you will make the mistake of thinking that it is Brother A. E. Williamson that is here; it is Brother Fred Williamson.



Brother A. E. Williamson.      Brother Fred.

Sister Van Amburgh, of Northfield, Minn.: I want to testify to the glory and love of the Lord, the love which he has given to me, and which I have in my heart, and I want to say one thing: I have been passing along the streets of this city already, and you can always tell the Lord's children, because there is such a heavy smile on their faces, even though you do not see the badge; and such hearty handshakes, and such love beaming in their faces! I praise the Lord that He has given me the privilege of coming to this convention. I have been to quite a number of conventions and each one is better than the last. Praise the Lord for this privilege!

Brother Williamson: Sister Van Amburgh has learned that the badge of the convention people is the convention smile.

A Brother: I am a representative from the penitentiary; they paid my expenses. I had no idea of coming to this convention two weeks ago. I have never been to a convention since the World's

Fair, but I have learned that they have been getting better ever since. You can imagine how full my heart is of joy today.

(It will be interesting to the friends generally to know that the inmates of the penitentiary are paid only a very small amount for their services when they work overtime, and these dear brethren in the Ohio penitentiary contributed of their money, earned in this way, to assist another brother to attend the convention; thus giving us a noble example of laying down our lives for the brethren.)

In this connection we might say that there were numerous instances where friends who were not able to pay their expenses to the convention were helped by others to do so. One brother had no money with which to come and had no thought of attending the convention until the day before the time to start, when he received an envelope containing the necessary money for expenses and a note simply reading: "Go to the convention."

What a grand opportunity these conventions give for those who have of this world's goods to assist some of the dear friends who are without financial means to attend, and thus both receive a rich blessing from the Lord. We rejoice to learn that so many of the dear friends have thus appreciated their opportunities and stewardship. Several of those who had been thus assisted, and who had not previously taken a positive stand for the Lord, were so impressed that they consecrated themselves to His service and there and then symbolized their consecration by immersion.

One dear sister said that she wanted to come to the convention but did not see how it could be, but she asked the Lord to open the way, and almost the last moment He did so, and she was rejoicing. In closing her testimony, she said: "I am so happy because I stand on something I know is sure, 'The Word of the Lord standeth sure.'"

A Sister: My heart is overflowing to be gathered here with so many of the Lord's dear people, and it seems to me that you might just as well try to turn back that great cataract with a teaspoon as to try to keep me from saying how thankful to the Lord I am this afternoon for all His blessings. I rejoice that the Lord has given me the privilege of being here. It is my seventh or eighth convention, I do not know just which, and it seems to me that those who have never attended a convention do not realize the great blessing that comes with it. I said to one dear brother who never has attended a convention, "Brother, when you get into the Kingdom, you will feel like a rat in a strange garret; you will not know the people; you do not get acquainted." I am thankful that I do know so many of the Lord's dear people. I ask the Lord's blessing upon us all.

A Sister: I thought I would not be able to attend this meeting at all because I did not have the money, but a sister in the Truth who could not come says: "I will stay and take care of your mother for you." And now she is at home rejoicing that she has found some way in which she can lay down her life for one of the brethren, while I am here getting the foretaste of the glorious convention to come, and can take back the overflowing part to her.

A sister from Cleveland, Ohio, sent the following message to the convention through another sister: "Having done all stand."

A Brother: The friends on our train very early this morning opened the convention by singing a hymn and I have obtained already a joy that fills my heart.

A Brother: I love to tell the old story, because this is the sixth convention for me, because I am happy, and the Lord has been with me all this time. I am glad to be here the second time. I was here two years ago and I have been rejoicing ever since.

A Brother: I desire to express thankfulness to the Lord for His favor in allowing me to come all the way from Nova Scotia to be with you and to hear your words of cheer and praise unto the Lord. I bring you greetings from the dear friends throughout the Maritime Provinces, and ask your prayers for their blessings that they may be faithful until they receive the crown.

A Brother: For months and weeks I have been desiring to be at this convention with so many of like precious faith, and I have been anticipating a great blessing. I am sure that before I arrived here I received a blessing, for my heart was overflowing on the boat from Cleveland to Buffalo. This is not my first convention. I have been at conventions of those of like precious faith since 1892, in Allegheny, when the number was comparatively small to what it is now; but I see the same smile, I see the same greetings, and I hear the same "blessed be the name of the Lord," and I rejoice. Some of my neighbors said to me, "How can you leave all your things behind you?" I said: "I will leave them all at home and not think of them again until this convention is over." It has always been my privilege to go back home and take care of my temporal affairs, and I have always been abundantly blessed in so doing.

A Brother: Two years ago my wife attended a convention, and she brought back such a load that I thought best for me to come and see what I could do. Already I am filled to overflowing. I thank the Lord I am here.

A Brother: My blessing started the moment we started on our journey to the convention.

A Brother: I want to say that I rejoice in the old, old story that has done so much for me. I came on the special train from Chicago. Just think of it, a special train of Dawn readers! I have heard of remarks made by a minister that he would not offer Millennial Dawn to his worst enemy. Think of the contrast; I would offer it to my best friend.

Sister Friese, of Boston: I wish to tell you of my experience at my first convention. I got a seat in the corner, and sat there and watched the others having such a beautiful time, and wondered why they did not love me as much as they seemed to love one another. While I sat there, very lonely, and wished I had not come, there came in presently one of the dear New York sisters, and she went around to each one and said, "I want to meet each one of you; I want to become acquainted." I said to myself, "I would like to be like that sister, and the Lord helping me, I will try to cultivate that spirit, and I will try to be like her." And so I want to say to those to whom this may be their first convention -- just ask the Lord to give you grace and strength to overcome your own nature, and reach right out to the brethren. You will not find them backward in greeting you. But if you sit back in the corner, we do not know but that you are tired, and resting, and do not want to be disturbed. But just come right out and you will find how much we love

you. We all know the Scripture is true, "By this shall all know that ye are my disciples, if ye have love one to another."

A Sister: I have been at a convention all summer. We drove from Illinois through Ohio to Pittsburg, and there was not a mail-box along the way at which we did not stop and put in a tract. We had a glorious time.

Brother Harrison, of Manchester, England: I have been asked by the Manchester friends that whoever I met of the Lord's people, to give them as our message, Psalms 121:7, 8, "The Lord shall preserve thee from all evil: He shall preserve thy soul. The Lord shall preserve thy going out and thy coming in from this time forth, and even for evermore."

A Brother: I am sorry to say this is my first convention, but as Sister Friese has testified that those who are at their first convention should not be backward about saying things, I feel it a duty incumbent upon me to tell you that I rejoice in present truth and rejoice in the privilege of fellowship with the dear brethren. We have been trying for the last three years to get to a convention, but the dear Lord has seen fit to keep us back until this time. Don't you know, brethren, it is as true in this case as it ever can be, that "absence makes the heart grow fonder." If you could realize the joy in our hearts, I am sure you would rejoice with us. Now I am glad to tell you, dear friends, that about three years ago I went to a funeral and happy I was, strange to say, to bury the old man in consecration, and I rejoice now still more to tell you that next Monday afternoon I am going to do it formally, so as to keep him more dead than ever.

Pilgrim Brother George Draper: It is because of the love of our dear Heavenly Father that we are assembled here. That love has been manifested to me this year in permitting me to attend two general conventions. We realize the Lord is abundantly able to do this, and He has admonished us, to not forsake the assembling of ourselves together, and so much the more as we see the day approaching. We realize the day is approaching and is very near at hand. And now that the Lord has admonished us thus, we are sure that He is capable of calling in all of His various bank accounts, so to speak, because everyone of us is only just a steward over the dear Lord's possessions. I consecrated all of my possessions to the Lord twelve years ago, and only recently the Lord permitted me to handle them at all. I have been trying to sell them and do something for the Lord, but the Lord did not want me to do anything for Him, He wanted to do it all for me; and in due time, the Lord permitted that sale to take place so quickly that I did not have anything to do with it at all. So, if you have been permitted to come to this convention through the help of our dear Heavenly Father, it is merely because He is calling in some of these bank accounts and using them for the blessing of His dear ones. I thank the Father that I am here. I know the "old man" Draper would not have helped me to come at all, so I am sure, dear friends, that the only one I have to thank for all of the blessings and privileges I have is the dear Heavenly Father, whatever the means used may be.

A Sister: This is my first convention. The question came up in our class, who could go to the convention? And I said I could go if someone would buy me a ticket, and that is all the way that I can go. And so it is in the Lord's providence that I am here.

A Brother: The reason that I am so anxious to get up and testify is, that it was a testimony meeting that brought me in. I got in a testimony meeting, where one of the sister's testimonies just threw me over, and I cannot stay down any longer.

Brother Williamson: I do not want this testimony meeting to close without giving my own testimony. I just want to give it in a few brief words. I am still trusting in the Lord. I remember a dear brother who used to be associated with our congregation at Allegheny, our beloved Brother William M. Wright. Sometimes after he had been away on his long trips that he used to make, he would come in very late in the evening and get into our prayer meeting, and he would be exceedingly tired, hardly able to say very much, but he always wanted to say something, and as he would arise, he would say, "I am not able to say very much tonight, dear friends, but I am still trusting in the Lord." And I always want to say that much whenever I attend a testimony meeting.

One little girl, eight years old, was heard to make the remark: "I don't hear anything here but 'glad.'" That one word certainly expressed the sentiments of all, for all were glad.

At the close of the testimony meeting, various announcements were made by the chairman, including instructions for the Colporteurs to meet at certain places in the hall and receive their badges. Those who were already in the work were to receive white badges, those intending to enter the work were to receive a gold badge, while those desiring a companion in the work were to receive a red badge in addition to their other badge.

## Evening Session

7 o'clock P.M. Praise Meeting led by Brother W. J. Mills of Hamilton, Ont.

*Discourse at 7:30 p.m. by Pilgrim Brother W. M. Hersee of Hamilton, Ont., on the text found in Col. 1:27: "To whom God would make known what is the riches of the glory of this mystery among the Gentiles; which is Christ in you, the hope of glory."*

(We will be able to give only a brief outline of Brother Hersee's discourse, as it is necessary, even if not desirable, to condense some of the proceedings of the convention. The dear friends will remember that there were one or more overflow meetings each day of the convention, and it would require more space than we have at our command to print everything in full.)



Brother W. M. Hersee.

Brother Hersee said, in part:

Dear Friends: It gives me great pleasure to be here this evening. It seems to me that every convention is getting a little better; and, judging from your faces, I think you will all say amen to it. We might well ask ourselves, why is this? One reason is, that the light is growing brighter and brighter, and the faces of those who are walking in the light will naturally shine. While meeting so many of the friends today I was considerably surprised to see the number of young people who are coming into Present Truth. Why is this? You all, I trust, realize that the general call ended in 1881, and when we see so many young people



coming into Present Truth at this late hour, we cannot help but say, why is this? Would God call any to this glorious High Calling, if there was no hope of their attaining it? Would any earthly parent set before his children something that would be impossible of attainment? Surely not. So, as we look upon the scene and recognize that so many young people are coming into the truth at the present time, after the general call has ceased, and many of whom were not in existence at that time, we recognize clearly that the plan is the Heavenly Father's plan from A to Z, and our dear Lord and Master is working out that plan in harmony with the Father's will.

(Brother Hersee then gave a full outline of the plan in general, showing the fall of man into sin; how God's plan -- the mystery -- for the recovery of man from the fall and its effects, was hid all down through the past ages; tracing step by step the various features of the plan, and finally how we, the Church, in this present Gospel Age, are permitted to understand the mystery, as none in the past were permitted to understand. He brought the subject down to the present time, the harvest, showing how our Lord who as the Chief Reaper, is permitting us to have a share in this glorious harvest work and that by and by we will have the glorious privilege of taking to the world the water of life. That having these privileges at the present time, we should use them faithfully, remembering that we are still walking by faith and not by sight.)

## **SATURDAY, AUGUST 31**

*Convention opened at 9:30. Praise and Testimony Meeting led  
by Brother T. E. Barker, of Boston, Mass.*

A Brother: I have been enjoying this feast of fat things. We are somewhat surprised when we go out and mingle with the world at large and see the amount of selfishness manifested, and when we come back to the Lord's people and see that selfishness put away, and everybody feeling good, and everybody is looking up and thanking the Lord for the great blessings that have come to us, we rejoice indeed.

A Brother: I desire to submit a question: "From what point can any man start, and by continuing to move forward from this point gain every good thing, including everlasting life, and yet always remain at the point from which he starts?" Answer: "The point is, known duty -- the duty that we know.

A Sister: During the one day that I have attended this convention, I have been trying to think of some comparison with the truth. While sitting in the meeting yesterday afternoon, this thought came to me: I remember, as a little child, of hearing fairy tales, and how grand we thought they were, if they were only true; and I thank God that this real fairy tale has come to us in later years, and we believe that it is true, and we can appreciate it more than, as children, we could appreciate those fairy tales.

A Brother: While this old, old story has all the fascination of a fairy tale, yet the Apostle Paul tells us that we are not following cunningly devised fables. Praise the Lord it is true.

A Brother: I have been a missionary for five years in China, and I have tried to proclaim what I thought to be the truth; but after coming home, I received more light, and now I am glad that I can proclaim the truth of a Gospel of which I am not ashamed.

While in China, during the first part of my term there, I went out with our Chinese evangelist; I could speak very little Chinese and felt that I was very little use on the trip on which I went. When I got back, I told the Chinese evangelist that I was of no use; I could not tell the people what I wanted to of the Gospel, and he said, "O, yes you are; you are our signboard; you attract the people, and we can talk to them." I am glad that I can be a signboard now for the blessed light, for the greater light, and I want to do my best for Christ.

There were also many other good testimonies showing the love and joy of the friends, but space forbids reproducing all.

## **Discourse by Pilgrim Brother Isaac Hoskins**

*11 A.M. -- Discourse by Pilgrim Brother Isaac Hoskins, of the Bible House.*



Brother Isaac Hoskins.

Brother Hoskins spoke, in substance, as follows:

It gives me a great deal of pleasure, dear brothers and sisters, to come before you. I esteem it one of the greatest privileges and honors of my life to occupy this position of service in your presence this morning. It is a privilege of which I feel very unworthy. In fact, as I often contemplate the grandeur and the excellence of the heavenly message of divine grace, I think what a wonderful contract, what a wide difference there is between this glorious message and some of the vessels that our Heavenly Father uses in connection with the dissemination of this message. And so, as we look about us, as we go amongst the fairest, the most eloquent and the grandest among our race, there are none that can by any means compare with the glory of this great message, and the conviction settles down upon us after all that even the fairest and most glorious of the heavenly host would be none too good, none too fair, to be used of our Heavenly Father in proclaiming this message of redemption that His glorious Word contains.

I have no thought or expectation that I shall be able to bring a revelation of new things to you this morning. You know ours is the old theology; ours is not the new theology, and we do not attach our claims or place any importance upon the so-called new light, advanced thought, etc., and we are here this morning for the purpose of inquiring for the old paths. So, if we fail to deal with some of the mysteries of the Revelator, if we fail to unravel the mystery respecting the various horned beasts, the white horse, the man-headed locusts, etc., of the Revelator, I trust none of you will be disappointed. We trust that all of us here are impressed with a sense of the importance of learning well the old things: that we are under the impression the Apostle Peter had, when he exhorted the brethren and said he would not be negligent to put them in remembrance of these things, even though they had already known them, already heard them, and even though they were already established in the Present Truth.

The theme that we propose to discuss this morning is found in the fourth Chapter of 1st Timothy, a part of the 12th verse: "Be thou an example of the believers, in word, in conversation, in charity, in spirit, in faith, in purity." We remark that the word example is a very common one, the

significance of which you should all be familiar with. There are various meanings attached to this word. One of the important meanings sometimes given to it is that which is held up, a standard, a criterion, a measure by which other things are to be criticized, sized up, and measured. But we find that there is a wider meaning given to the word in our general usage today, and the thought generally attached to it is: that which is exemplified; that which is shown forth, held forth, and revealed, displayed. So that as that word is used with reference to persons or beings, it has reference to that which they display, their manner of conduct, their life, who are good or who are bad. So, your conduct, your manner of life, your example, may be a good one; it may be a very commendable one, or it may be a bad one, or a reprehensible one.

We are discussing this point this morning to show what importance and value there is in an example, and that the world of humanity in general is keen to recognize what power there is in the example of one person over another. For instance, we see how the world is very keen to note various examples among themselves; how they will pick out certain men who have been great or successful, according to their standards of success or greatness, and they inquire as to what were the means by which these men gained their greatness or their success; and they are very quick to follow the example, to follow the same course or manner of life they see exemplified by these great ones, in order that they may also attain the same success, or the same great end. It is true enough that the world's standard of what is great and successful is not always harmonious with ours, not always in accordance with the divine Word, but it is success that the world is after, and we mention this point to illustrate what very great power there is in one man's life over another, and what a great factor it is in shaping the course and the destiny of another life. And so, the Scriptures refer to the power and the influence there is in an example for good or for evil.

It has been truly said that there are four ways of knowing things - four ways by which things may be known: (1) By intuition; (2) By experience; (3) By observation or example, and (4) By information. We recognize at once that we cannot know things by intuition, because to know things by intuition signifies to know them without the necessity of any process of reasoning. We recognize that God only has this way of knowing things; He only may know things by intuition, without any process of reasoning, without any philosophizing or theorizing about them; He knows them because knowledge is inherent to Himself, just as the Scriptures teach that immortal life inheres in Him, and He does not depend on any outside source for His existence or His supply of life. So we can know things only by three ways, so far as mankind is concerned.

We stop a moment and look at experience, and at once we recognize what an expensive way that is of learning things; how much it generally costs us to learn things by experience. How many bitter tears, how much agony we expend in the lesson that we obtain through experience! Very properly then may we seek as far as possible to learn life's lessons through these other ways than by experience, because it is such an expensive way to know things.

We have then by observation, or example, and by information, two important ways of knowing things, and these two ways we would do well to take heed unto, that as far as possible we may learn that which our Heavenly Father has for us to know, and thus avoid some of the pains, some of the agony some of the distress that generally comes to those who learn by experience.

We look back to the example of our first parents in Paradise. We see their situation there, their surroundings, their conditions, and from the record we gather the thought that they could not know anything except by the one way -- by information. They could not have learned by experience, because they had never experienced sin. They had never disobeyed God, and therefore had never come under any penalty for sin; they could not therefore learn things by experience. Well, someone would ask, perhaps, if observation or example is such a good way to know things, why did not our first parents learn the lesson of sin and the exceeding sinfulness of sin by observing it? Again we are forced to the conclusion that they could not know anything by observation, because there was no instance of sin in the world. We have no record that there was any sin in the world previous to the time that our first parents disobeyed God's command, and there was no death in the world previous to that time. We may well imagine that if our first parents could have seen outside of Paradise, and could have had a lesson by observation, could have had an example of sin and its awful consequences, that they might have learned this great lesson of obedience to God and submission to the divine will without having to go through all of these distressing experiences for the past six thousand years. For instance, we will suppose that our first parents could have seen this day, and could have seen the human race steeped in sin and death, suppose they could have seen their posterity from that day down to the time of the flood, then from the time of the flood down to the first advent of our dear Redeemer, and then from the first advent down to the present time -- suppose, for instance, that by some power they could have seen all the effects and consequences of sin during all of this time; do you not suppose that this sight would have caused such an impression on their minds that it would have constituted an everlasting lesson to them, and thus would have saved this awful experience the race has been going through for six thousand years? Then if we recognize what a power there is in an example for good or evil, and when we recognize that the Bible holds up example or observation as being the important way of knowing things, we do well to take heed unto this way, and to see how we can properly profit by all that we see around us and all the examples about us, and learn as many of life's lessons as possible without being forced to go through the severer experiences.

So the Scriptures bring to our attention as God's children some very valuable and some very important examples. And the first of these we find is in our Heavenly Father Himself; that He is declared in the Word of God to be the great example which we as His children should copy and to which we should conform our lives and our characters. We find this matter very concisely stated in the words of our dear Savior when He said, "Be ye therefore like unto your Father in Heaven," and again, the Apostle, representing God as speaking, says, "Be ye holy, for I am holy." and again the Apostle, speaking of those whom God is now calling to enjoy special favors, says that God has predestinated that these shall be conformed to the image of God's dear Son; and to be conformed to the image of God's dear Son signifies to be conformed to God's own image, because our Lord's character and disposition and mind was exactly like that of the Heavenly Father Himself; so much so that He could say when He was amongst the human race that he who had seen Him had seen the Father, and that He and the Father were one.

Again the Apostle, in representing how God is going to unify all things and make them like unto Himself in the future, says, that in the dispensation of the fulness of time God will gather under one head, under one arrangement, all things in Heaven and all things on the earth, even under Christ. But we now desire to come to a text that seems to be a climax of all of them. They are the words of the Apostle Paul: "But all with open face, beholding as in a glass the glory of the Lord,

are changed into the same image from glory to glory, even as by the Spirit of the Lord." I hope we all get thoroughly the significance of this expression, "we behold as in a glass the glory of the Lord." And the result, says the Apostle, is our change, our transformation of mind like unto that of our Heavenly Father. If we really get the proper significance of this language of the Apostle, we will find that the ultimate purpose and intent of all of God's Word, and His directions and instructions to us is, that we might be made like unto Him -- made like unto our Heavenly Father. It is not sufficient that we have a very clear understanding of the divine will and purpose; it is not enough that we have a pleasurable realization of God's forgiveness of our sin; it is not enough that we exercise ourselves to a great extent in disseminating this great message to others; we might do all of these things and more, yet if we are not letting the glorious light and influence of God's truth have its proper transforming effect upon our own minds and characters, we are missing the great end, the great object for which that truth was given. So, it is not a matter of how many sermons we preach or how many tracts we distribute, or how much money we may devote in the Lord's service; we may do all these things, and yet if we are not allowing the transforming influence of God's truth to shapen our lives, and make us like unto our Father in Heaven, all these other works will avail nothing. Even as the Apostle says: "Though I speak with the tongues of men, and of angels, and have not love, I am become as sounding brass or a tinkling symbol. And though I have the gift of prophecy, and understand all mysteries, and all knowledge; and though I have all faith, so that I could remove mountains, and have not love, I am nothing. And though I bestow all my goods to feed the poor, and though I give my body to be burned, and have not love, it profiteth me nothing." That is, if I have not this great quality of love which comes in connection with the transforming work, it profits me nothing.

So the object and purpose that we have as God's children in studying His Word is not merely to see how much we can know, how much we can satisfy our curiosity, but it should be with the thought in mind of bringing our hearts and minds into closer touch and sympathy of the great divine mind, making ourselves more and more like unto our Father in Heaven. You know the apostle says, "This is the will of God concerning you, even your sanctification -- your setting apart, your transformation."

Now this language we quoted above, "We all with open face," signifies a great deal. It signifies that all who are not experiencing this transformation are not of the class; they do not come under the direction or the blessing that is implied in this text. Therefore it is not a question now with you or with me as to whether we have made a consecration; the question is, are we in accordance with that consecration submitting ourselves to all the transforming influences of God's Word and shaping our own dispositions and our own characters and making them like unto our Heavenly Father? The Apostle says, "We all with open face." I hope we get the full significance of that expression. It signifies, without any veil, without any intervening hindrance, prejudice or fear; that we read God's Word, we see His glory, with open face, without anything between our eyes and the Word we read. If we get the proper thought concerning that expression, we will recognize with a great deal of regret that the great majority of our Christian friends today do not read God's Word with open face; they do not see His glory without this intervening veil, because as we look at the various views advocated by the majority of the various denominations, we find that all of them are looking into God's Word with a very heavy veil of prejudice, superstition and misrepresentation, and that all of this stands as a great hindrance to their seeing God's glory and seeing His image, His likeness and His loving disposition.

Someone, perhaps, would ask: "In what way do Christians as a general thing allow a veil to hinder them?" We give, as an example for instance, the great doctrine of eternal torment that has been advocated and pushed to the front by the various denominations all along; the idea that our Heavenly Father, instead of being a God of love, instead of being a merciful and kind Father, one who was looking out for the very best interests of His creatures, from all eternity has provided an arrangement by which the vast majority of the human race shall go into an abyss of torture, misery and pain. We see, dear friends, that those who have such a conception of the Heavenly Father have a great veil before their minds which hinders them from seeing God's love, and from seeing His disposition. And again we see that those of our dear Christian friends who advocate that the present time is the only time of salvation are amongst the class who have a great veil over their minds which hinders them from seeing God's love and mercy.

Again we see that our dear Christian friends who are contending that God from all eternity past has decided and determined who shall be saved and who shall not be saved, even before they are born, and that there are infants in hell a span long, are amongst the ones who have a great veil over their minds which hinders them from seeing the glory and the order of the great divine plan.

But we thank God as we come to His Word that we are able to see and read in fairer lines His goodness, His love and His mercy; that in fact His whole arrangement, His whole plan, is one of mercy; is one that demonstrates and exemplifies a character of the very highest type, and it is this that we want to notice as we go along this morning, in order that we might see more clearly what the divine will and purpose concerning us is.

We wish to notice specially two of God's attributes, His JUSTICE and HIS LOVE. I have no thought, my friends, that I shall be able to say anything in regard to these two points that you have not before noticed, but we desire to review these matters in connection with our theme, in order to see in what sense God's example is one that we should copy after; to see to what extent and to what degree we have made progress in this way of copying after Him and conforming ourselves to His glorious image and likeness.

We notice, first, God's justice is brought to our attention in the very first statement, we might say, of God's Word. He tells us that His mind and His disposition is one to insist upon absolute righteousness, for the first statement of divine law is that death, destruction, shall be the wage, or consequence, of sin, or the violation of His law; and as we pursue the study of His Word, His law, and as we learn the condition of the human race all the way down the centuries, we see to what perfect extent our Heavenly Father has carried out this original characteristic, this great attribute of His. The whole human race are witnesses to this fact, how God has carried out this penalty of death, how He has seen that His justice has been recognized all the way along. And the great lesson, therefore, coming to us is, that justice is the foundation of God's throne, and not only so, but that God will maintain His justice inviolate at any cost.

Another point it brings to our thought is the fact that God can be just, the fact that He can maintain what He declares shall be, proves to us that God is unchangeable; that when He declares that His will is thus and so, and that men shall do thus and so as a result of certain actions in their lives, they can depend on it, and His Word will be carried out to the very last

degree. It gives us confidence in our Heavenly Father to see how firm He has held to His justice right along. Let us suppose, for instance, that a few years after He pronounced this penalty on our first parents, seeing the condition of man and how awful was his distress and suffering, God had said, "Well, now, that is a pretty hard lot; I guess that since you have repented and wished that you had not disobeyed Me, you can go back into Paradise. This has been a pretty hard lesson and I guess you have had enough, so you can go back." What would have been the result of such a course on the part of our Heavenly Father? The result would have been that, in following such a course, He would have undermined the confidence of His children in Him. They would naturally have reasoned like this: that if the Great Maker of the universe can change a dozen times; and, therefore, they would not have had any confidence in God for anything. But the fact that He has followed a different course, that He has maintained His principle of justice, that He has maintained His word by His course of conduct all along, gives us ground for the strongest confidence. And no doubt the words of the Apostle Paul were based on this fact when he said, "Wherein God, willing more abundantly to show unto the heirs of promise the immutability of His counsel, confirmed it by an oath; that by two immutable things, in which it was impossible for God to lie, we might have a strong consolation, who have fled for refuge to lay hold on the hope set before us; which hope we have as an anchor of the soul, both sure and steadfast, and which enters into that within the vail." I have no doubt that the Apostle's study of God's example, of His plan of salvation, gave him this impression; gave him a reason for uttering such language as this. So the great lesson coming to us as God's children is that we can depend upon Him; that we know if He has maintained His justice and righteousness throughout the ages, that whatever other arrangements He may make, that if He has arranged a plan for our redemption and rescue from sin and death, He will just as surely carry out that arrangement as He will carry out His arrangement respecting the preserving of His justice and His righteousness.

Then finally, what is the great lesson coming to you and to me respecting God's justice? It is this: that if we have been privileged to read God's Word with the eyes of our understanding opened, with unveiled face, we see that if God has been so careful and so thoughtful to preserve this principle of justice throughout the ages, how careful you and I ought to be in all of our conduct to preserve this great quality that God has placed so much value upon. For instance, if we get a proper view respecting the importance of justice, we will naturally inquire respecting the little transactions of life, whether this transaction or that transaction is just. In our thoughts respecting each other, and in our treatment of each other, we will naturally inquire, Well, now is this the proper thing for me to do? Is this just to my brother to talk this way about him? Is it fair to him to say this thing, or that? Is it right, or equitable, for me to treat my brother, or sister or fellow-being, like that? I really believe, my brothers and sisters, that if we would exercise more thought respecting this principle of justice, it would save us a great deal of difficulty and friction in our little associations and fellowships and gathering together. Let us therefore endeavor to keep this in mind.

We come now, for a moment, to consider God's love. You know we naturally like to think about God's love. We have heard about it all our lives. The Apostle says, Behold the goodness and the severity of God. Now mankind all along have not seen God's goodness; they have seen only His severity. His severity consists of the fact that God insists on absolute righteousness; that all along He has insisted on maintaining justice. Therefore the human race today sees only God's severity. As they witness the various difficulties and trials, and calamities, and distresses, amongst

themselves today, they naturally come to the conclusion that they do not see any love in these, and very properly so. We do not expect the world to see any love in the carrying out of God's justice. Only those who have the eyes of their understanding opened to see something of the lengths and breadths of God's great plan of salvation can see what there is in God's love behind all the present distressing order of things in the world. But we are privileged to see both the severity and the goodness of God. Those who by faith have recognized the validity of God's Word, those who have seen how true God has been, those who have seen the evidence that convinces them respecting the sureness of God's Word and truthfulness, only those recognize God's love in a way and to an extent that none others can. We see that though God has been just from the beginning, He has also had in mind His great principle of love, and this fact is confirmed by the expression of the Revelator who tells us that Christ Jesus was the Lamb slain before the foundation of the world; that before God undertook the carrying out of His great purpose of salvation, He had in mind a loving provision of rescue, of deliverance, from the awful condition of sin and death, and that this fact is furthermore declared by the prophet when he tells us that, after the human race had fallen into their condition of sin, God looked down from the height of His sanctuary; from Heaven did the Lord behold the earth; to hear the groaning of the prisoners; to loose those that are appointed to death; that this was God's mind, His will, concerning His creatures while they were yet in sin and under alienation and separation from Him; that God's love and mercy were in operation and were exercising themselves on their behalf. This fact was further declared by the prophet when he represented himself as the Lord Jesus Christ and those whom the Lord would associate with him -- "The spirit of the Lord God is upon me; because the Lord has appointed me to preach good tidings unto the meek; He has sent me to bind up the broken hearted, to proclaim liberty to the captives and the opening of the prison to them that are bound." These declarations, dear friends, were made way back in the ages while we were yet in sin and death, and as the prophet says when there was no eye to pity and no arm to save. Thus it was that the arm of the Lord brought us salvation. You know how beautiful the Apostle John sums up God's love. He says, Herein is love, not that we loved God, but that God loved us -- before hand, while we were yet sinners, God gave His only begotten Son that whosoever believeth in Him should not perish but have everlasting life. And the Apostle Paul says that while we were yet enemies, we were reconciled to God's justice by the death of His Son. So this, dear friends, was the first manifestation of God's love, the giving of His only begotten Son that we might live through Him, that we might have life, and have it more abundantly. Not only do we see God's love manifested in the gift of Jesus Christ, but as we get the eyes and ears of our understanding open wider, we see the next great step in His plan; we see how He has set apart in His great arrangement a dispensation of the fullness of time, when all mankind coming forth from the state of death shall have an opportunity to gradually rise and return to their former estate which was lost in Paradise. We naturally reason that even though God had taken this first great step, even though He had lifted the great penalty of death, even though He should awaken all the masses of the world from the tomb, that they would be very little better off unless He provided some arrangement for their deliverance from the various weaknesses and degradation, because there could be no change take place in death, therefore, when they would come forth from the tomb, they would come in the same condition they went into it, and if there should be any real or lasting benefits from this first great step He took in giving His Son, He must take another step and provide a power that could take hold of the weaknesses and frailties of human nature, and rescue them from that condition, and lift them back to that which was lost. We find that God's Word is full of this fact; that it is declared by all



of the holy prophets since the world began, that times of restitution have been promised, and that our Lord Jesus when He said He came to seek and save that which was lost, implied a great deal more than merely the giving of His life. It implied what many other Scriptures bring to our attention, namely, that there is a special age set apart in God's plan in which He is going to give to every creature under heaven, all mankind, a share in this trial for everlasting life, and He has provided a special arrangement, which the Scriptures call the kingdom of Heaven, and that the prophet Daniel was permitted to see something of this kingdom when he said, he saw the kingdom which had dominion under the whole heavens given to the people of the Saints of the most high, whose kingdom was an everlasting kingdom and whose dominion should never pass away.

We do not wish to take up very much time discussing this matter, because it is a point upon which you are all very familiar, and you all recognize more or less the facts relating to this matter. But God's plan is one that is going to manifest His love just as fully as it has manifested His justice and insistence upon righteousness. When the apostle says that God in the ages to come is going to show forth the exceeding richness of His grace, it implies a great deal more than what the majority of our Christian friends believe along this line. It implies what the Scriptures tell us, that, when our Lord Jesus comes the second time, and when He fulfills the various predictions respecting His second coming to the earth, He will take unto Himself His great power and reign and accomplish all that is written in the prophets respecting this Kingdom of Heaven, for which our Lord taught us to pray. "Thy kingdom come, Thy will be done on earth as it is in heaven."

Now we have had a general view of God's love for the world; we have seen something of His justice and something of His love. If God's character and example is held up to us as the one which we are to follow, what does it teach you and me respecting our course and example in life? It teaches us that if we are to be like unto our Heavenly Father; if we are to carry out this same principle of love He has been carrying out throughout the ages, -- that inasmuch as this love that God has is of a kind that took hold of creatures that are fallen who were in a state of alienation and separation from Him, that inasmuch as God's love was of a kind that could take hold of these and manifest itself on their behalf, -- it teaches us that if our love is to be like the Heavenly Father's; if we are the Sons of God and manifesting His character and disposition, that we, in all of our experiences and transactions, and doings, will manifest this same quality in the same way. That to those who may be our opposers, those who may be rebels from our standpoint toward the way of righteousness, those who may do us injury, those who may seek by every means to interfere with our plans and to discourage us in the way of righteousness, we will still manifest this same disposition and mind our Heavenly Father has been manifesting, namely, that we will love our enemies and pity them, instead of doing them an injury, just as we see that God has been arranging a plan that will result in great blessings and favors to those who have opposed Him, and have been violating His character and principles of righteousness, all down the ages of the past.

But what shall we say furthermore of God's love? We have seen how the Scriptures so beautifully picture to us God's plan respecting humanity in general, but there is a still fairer picture of God's love and that this picture relates to the present time; that since our Lord Jesus has come into the world, the Apostle calls our attention to the fact that now there is a special

arrangement in order, which means that unto us are given exceeding great and precious promises whereby we shall be made partakers of the divine nature. Now we all know that is a very great promise. There is a great provision that man should have an opportunity of being awakened from the tomb and returning to that which was lost; but the Apostle speaks of the promises given unto us at the present time, previous to the time of the blessing of the world in general, and He calls our promises exceeding great and precious. That is, they are promises which exceed every other promise. He recognizes the fact that God's promises are of a different grade; that He has some promises implying blessings to a certain extent, but that He has other promises implying greater blessings. So the Apostle says, Unto us are given exceeding great and precious promises, that by these we might become partakers of His own nature. We are all more or less familiar with Scriptures which declare that the present time is one of very special favor and opportunity in which a few, as many as the Lord our God shall call, shall have the privilege of association with Jesus Christ and His sufferings, by filling up that which is behind of the afflictions of Christ and of sharing with Him in the glorious inheritance of being made like unto our Father in Heaven, being made a partaker of the divine nature, far above angels, principalities and powers and above every name that is named.

You know the prophet calls our attention again to the matter of the special experience that we have had in the present time. He tells us that God has delivered us from the horrible pit and from the miry clay and placed our feet upon the rock Christ Jesus, and He has put a new song into our mouths, even the loving kindness of our God. So we may well sing,

"Rock of ages cleft for me,  
I am hidden safe in thee."

What shall we say, dear friends, of this great love that has come to us? We see that God has loved us far beyond our worthiness, and far beyond what he is going to manifest to humanity in general. It gives to us an inkling of what God expects of us if we are to be made copies of His Son and like unto our Father in Heaven. It signifies that we will exercise ourselves to the last degree in blessing those with whom we come in contact and in doing good to all as we have opportunity.

Now the Scripture brings to our attention other examples for our profit and blessing and edification. You know the Apostle James says, Take, my brethren, the prophets for an example of suffering affliction, and of patience. We ask why? Because the Scriptures tell us that these prophets had the testimony that they pleased God; that they did that which brought God's approval and made them acceptable to Him, and therefore we are to take the prophets for our example. The apostle tells us how they were willing to endure affliction, and how they suffered and how they were stoned and sawn asunder; how they faithfully endured all of these things, and how it was this faith in God, this submission to the divine arrangement under the most trying and severe circumstances, that brought God's approval. Take these, the Apostle says, for an example of suffering and patience, that you also like them may obtain the testimony that you please God and thus finally and everlastingly with His approval.

Then there is another example the Scriptures bring to us; the Apostle calls our attention to how God when He was dealing with the children of Israel, leading them forth in the wilderness, was

not well pleased with many of them, because they were unfaithful; that they murmured and complained because everything did not go just as satisfactory, according to the flesh as they desired, and he tells us that, because of their murmuring and complaining disposition, specially prepared punishments were given, and finally he sums up the matter by saying, how all these things happened unto them for our example, that we through the faith and patience set forth in the Scriptures might have hope.

Finally we come to the consideration of our own personal example, and the influence each one of us, as God's children, has over others. The Apostle Paul surely recognized this when he said, "Be thou an example of the believers, in word, in conversation, in love, in spirit, in faith, in purity." We believe that men and women of all denominations and all classes recognize more or less the influence of their example upon their associates and upon those around them, and yet there seems to be a general failure on the part of most everyone to really appreciate how far reaching example is. Because of this lack of recognition and appreciation, God's children are really missing a great many blessings they might otherwise enjoy. We see how susceptible a child is to the example set before it. Most every parent recognizes how quickly a child learns to do the things it sees the parent or the older children do. This very fact should convince us all of how there is an influence going out from our actions and words that has an effect on those around us. Sometimes some of us are inclined to excuse ourselves for doing certain things by saying, "Well, Brother Smith, or Sister Jones, does this thing, or that thing, and I guess it is all right for me to do it, too." Right here is where we should draw the line. We are not to follow the example of those around us in doing things which we know are contrary to God's Word. We are not to base our conclusions on other people's example, but we are to watch their example, and see to what extent they are in harmony with God's Word, and to that extent we may follow it, and at the same time realize that we ourselves have a great power and influence for good over our brothers and sisters. It is a two-fold power. In setting a good example, in doing that which we recognize would be harmonious with God's will, we are not only helping ourselves and hurrying the work of grace in our own hearts, but reason, the Apostle says, "Be thou an example of the believers." Thus you will not only help yourself, but you will help others in this work of grace, assisting to build them up in the most holy faith.

But, says one, Suppose I do set a good example, and those around me do not recognize it; suppose they have different ideas from mine; what then? Someone would say, "I think you ought to attend to their cases, I think you ought to give them a good slighting; let them know you are dissatisfied, and that your example is the one for them to follow." What do you think about that? God forbid. I trust that all of us, by His grace, have the eyes of our understanding sufficiently open to see how very wrong such a course would be, to see how it would be in direct violation of the principles laid down in God's law, that it would be a flat contradiction of the command given us by our Savior when He said, "A new commandment give I unto you, that ye love one another." We are not to set our own example up as a standard and measure everybody else by it. We have no authority in God's Word to set standards for others and then judge them because they do not see things as we see them; but to let other have their own ideas and their own way of seeing things, and to allow our quiet example to do the correcting of those around us, without taking into our own hands the power and authority, which belongs to God alone, of judging and determining who is right and who is wrong.

We trust these things, as we have reviewed them this morning, have assisted us to see more clearly the proper course along this line, and that if possible we will exercise greater care, greater influence, and greater concern, respecting our own example, to the intent that it might not only help us, that it may not only hasten the work of grace in our own hearts, but that it may help those with whom we come in contact. I was very favorably impressed yesterday with what our dear Brother Williamson brought out that, in our fellowship and association in this place how much more blessed it would be for all of us to be concerned about the interests of our brothers and sisters, and not to be thinking first about ourselves in regard to this particular matter.

So, as we come to appreciate the fact of how valuable and far reaching our example is, and what influence it has for good or for evil, and when we recognize that God has marked out this way as one of the principal means by which we can help our brothers and sisters, I trust that we will give more concern and be more interested in looking after our own example, that it may be more and more like unto our Heavenly Father's. You know our Lord recognized this thought when He said we should let our light so shine before men that they seeing our good works would glorify our Father which is in Heaven. Now what is this but learning and observing by example? Let your example be such before men that the result will be, they will glorify your Father in Heaven. Our expectation is not that men will glorify God at the present time, but the Apostle Peter explains the matter when he says, that having our conversation honest before the Gentiles, that whereas they speak of you as evil doers at the present time, they will in the day of visitation glorify God on your behalf. And so, in this way, we ought to let our lights shine by our example, by our course in life, and as the Apostle says, be living epistles, known and read of all men. And if we do this, we cannot help but be more and more made like unto our Father in Heaven; and thus fulfill the injunction of the beloved Apostle when he said, Be thou an example of the believers, in word, in conversation, in love, in spirit, in faith, in purity. Amen.

### **Discourse by Pilgrim Brother John E. Streeter**

Praise Service led by Brother John J. Kuehn, of Cleveland, O., from 7 until 7:30 P.M.  
*Discourse by Pilgrim Brother John E. Streeter, of Providence, R.I., at 7:30 P.M.*

Brother Streeter's discourse was, in substance, as follows:



I desire to read for our lesson the first chapter of the Second Thessalonians:

1. Paul, and Silvanus, and Timotheus, unto the church of the Thessalonians in God our Father and the Lord Jesus Christ:
2. Grace unto you, and peace, from God our Father and the Lord Jesus Christ.
3. We are bound to thank God always for you, brethren, as it is meet, because that your faith groweth exceedingly, and the charity of every one of you toward each other aboundeth;
4. So that we ourselves glory in you in the churches of God for your

patience and faith in all your persecutions and tribulations that ye endure.

5. Which is a manifest token of the righteous judgment of God, that ye may be counted worthy of the Kingdom of God, for which ye also suffer:

6. Seeing it is a righteous thing with God to recompense tribulation to them that trouble you;

7. And to you who are troubled rest with us, when the Lord Jesus shall be revealed from heaven with His mighty angels,

8. In flaming fire taking vengeance on them that know not God, and that obey not the gospel of our Lord Jesus Christ:

9. Who shall be punished with everlasting destruction from the presence of the Lord, and from the glory of His power;

10. When He shall come to be glorified in His saints, and to be admired in all them that believe (because our testimony among you was believed) in that day.

To get the sense of the Apostle' words here it will be best to leave out the parenthesis, and study that afterwards under the two distinct things referred that shall be manifested at the appearing of Jesus Christ, "when he shall come to be glorified in his saints" -- that is one thing, and "to be admired in all them that believe in that day." So whatever day that is, it follows that at that time the Lord will be glorified in His saints, and in that day there will be those who believe.

"Wherefore also we pray always for you, that our God would count you worthy of this calling, and fulfill all the good pleasure of his goodness and the work of faith with power; that the name of our Lord Jesus Christ may be glorified in you, and ye in Him, according to the grace of our God and the Lord Jesus Christ."

I want to call your attention first to the only part of our talk tonight which will be specially practical, because I am sure of one thing: that you will get something tonight to carry away with you that will be a help to you, and that will be an exhortation to you, and to a practical Christian life. The first exhortation that is brought out in this message of Paul's to the Church at Thessalonica, is, "Wherefore also we pray always for you that our God would count you worthy of this calling, and fulfill all the good pleasures of His goodness, and the work of faith with power." This is the exhortation. Now, you would not need to remember anything which I have said tonight to get the benefit of this exhortation, for you can read it in the letter for yourselves every day.

Then I want to notice the words of the Apostle to this Thessalonian church, "We are bound to thank God always for you, brethren, as it is meet because that your faith groweth exceedingly." Now that will be an exhortation to us. It will be an incentive that we seek to use those things which the Lord has given to us in order that our faith may grow exceedingly. "And the love of everyone of you all towards each other aboundeth. So that we ourselves glory in you in the

churches of God for your patience in faith in all your persecutions and tribulations that ye endure."

Now this is the practical part of our message tonight; that which we desire particularly to call to your attention is more along doctrinal lines; but we cannot ever separate the doctrinal teachings of the Scriptures from practical living.

I want to call your attention to the 4th, 7th, 8th and 9th verses. You will notice that the theme suggested is the second advent of our Lord Jesus Christ. The Apostle Paul in every epistle which he wrote gave special emphasis to this doctrine -- the second advent of our Lord. The second advent of our Lord is clearly associated with the first advent. The first advent was designed to accomplish a particular work, and we are very sure that when the first advent was completed, and our Lord had ascended on high, the work that was designed of our heavenly Father in His plan for that advent was accomplished. And as we turn to discover in the Scriptures what that work was, we find it very clearly and plainly stated that it was to give Himself a ransom for all mankind. There is nothing more clearly stated in all the Scriptures than the fact that the death of our Lord Jesus Christ was for all mankind -- not only for those who would believe in this long night of weeping, but for all, for we have the Scriptures clearly declaring that He became "the propitiation for our sins, and not for ours only, but for the sins of the whole world." So then, when our Lord Jesus accomplished the work for which He was sent, He had become the owner of the race. Whatever the purpose was in the purchase of the race is another matter; but we are very sure reason teaches that there must have been an object in God's instituting a plan providing a Redeemer -- one who would ransom all mankind from the sins which came upon all through the disobedience of Adam.

So we desire to emphasize this: that our Lord came to taste death for every man; and also another statement of Scripture which declares that this testimony will be given to every man in God's due time. I do not care how many there are who have never heard this testimony, you may be sure they will all hear it in God's due time, and they will hear it in order that they might benefit by it, in order that the purpose of God for them might be accomplished, which is to enlighten them concerning His purpose for them, and that the Son of God died for them also.

Now in considering the Scripture read as the text, we want to notice that almost every feature connected with the object of our Lord's second advent is touched upon, but it is necessary in order to understand these distinct features to compare Scripture with Scripture, so that we will not wrest the Word of God. And in considering the Scripture read as the lesson we note, first, that the Lord's advent is to introduce a day -- "in that day." I am sure that everyone here who is familiar with the Scripture knows very well that the day referred to is not a literal day of 24 hours. The Scriptures very often refer to long or short periods of time as "days." We believe that the day referred to here is the day so often spoken of by God's ancient prophets. "In that day shall this sign be seen in the land of Judah: salvation to our God," etc. "In that day the Lord of hosts shall make unto all people a feast of fat things." It is the same day. It is not our day, for we are living in a day brought out in contrast with this day. You will notice that the Scriptures in speaking of this day, which is yet future, speak of it as a long day. The Apostle Peter evidently refers to its length when he says, "One day with the Lord is as a thousand years, and a thousand years as one day." It is the thousand year day of Christ, the reign of Christ with its saints, that is

evidently referred to here in the text where the Apostle says many will believe in that day; he speaks of those who will believe in that day.

Now notice that the terms used in this figure are not only of a day but of a night also. In the 30th Psalm, 5th verse, we read, "Weeping may endure for a night, but joy cometh in the morning." So we have in this statement of the Psalmist, as well as in other statements of the Scripture, the long period of human suffering since the fall of Adam, the long period when the whole creation has been groaning and travailing in pain together, and it is spoken of as a night as contrasted with this day referred to in the text.

When it is night it is always dark. Night is always associated with darkness, and it means this: darkness concerning God's purposes, lack of knowledge. As we look over human history we find that only a few, comparatively, of mankind, have had any knowledge of God, -- a night in the sense that it has also been a time of suffering, of darkness, of ignorance concerning God and concerning His purpose for them.

Now I want to notice that there is another Scripture writer, the Prophet Isaiah, in continuing to use this figure of speech -- night and day -- makes an inquiry. You remember it was the custom in those days for a sentinel, or watchman, to stand in the night upon the walls and declare the time of night. And so we have the Prophet making this inquiry: "Watchman, what of the night?" The answer is very indefinite: -- "The morning cometh, and also the night." It was left for another inspired writer to make this answer more definite. This answer that was given to the Prophet Isaiah was made 750 years before Christ, and about 60 long years after Christ's birth we have another inspired Prophet who answers this question. You remember who it was. It was the Apostle Paul. And he tells us that the night is far spent and the day is at hand. That was back in his time. And as we look over the matter very carefully, dividing up the period of 6,000 years of human history into a night of 12 hours, it is very easy to see that in the Apostle Paul's day the night was far spent, and we can determine something concerning what time it was in the night. And so dividing the 6,000 years up into 12 hours it would make 500 years to an hour. When the Apostle Paul wrote these words it was nearly 4,200 years after the fall of mankind. What hour of the night would it be then? We answer, it would be about 2 o'clock -- what we would call morning. That would show to us that we who are living in this day ought to be on the alert to discover whether we are not already in the dawning of this day referred to here in the Scripture.

I want to call attention to another point brought out in this same scripture: The Lord's advent will not only introduce a day -- the day referred to by the holy prophets of a thousand years in length -- but the Lord's advent is for the purpose of delivering the church from affliction, from tribulation, from persecution, and in connection with this deliverance we have had stated by one of the ancient writers, the Psalmist, that the Lord's people in the dawn of this morning would have special help given to them, because in the dawn of this morning the prophets have declared it would be absolutely necessary for the Lord's people to have special help, in order that they might not only see clearly through the clouds over into the age just beyond, but that they might be kept in the hour of trial which comes to try all at that time who dwell upon the face of the earth. So the Lord's advent is for the purpose of delivering the church.

I want to note that very day as it is dawning, and we read in the 46th Psalm, 5th verse, that the church will be helped specially in the dawning of her morning. You remember the Psalm. I will not turn to it; you have doubtless read it very many times; but read it over again. The word church is not used there, but the Lord's people, the church in the close of this age, are referred to, and in that time of trouble, which the context clearly intimates will occur at that time, then the Lord will give special help to His people, and will deliver the church at that time.

Then again we notice that every day is ushered in by a sun rising. So this day will be ushered in by a sun rising. You remember in the 4th chapter of Malachi we read, "For behold the day cometh that shall burn as an oven; and all the proud, yea, and all that do wickedly shall be stubble." Now that day, some of our friends have supposed was 24 hours long, failing to see that it referred to a period of 1,000 years in length. The fire referred to will begin in the opening of that day, and burn very fiercely in the opening period, and will burn all through the 1,000 years and at the end there will again be an increase of its fierceness until all those who are opposed to God and everything that is in opposition to Him will be destroyed. But it takes the whole thousand years to accomplish this, and not one literal day.

So every day has its sun rising; and we read right in that connection, that "unto them that fear my name shall the sun of righteousness arise with healing in his beams." Now we know very well that the sun of righteousness refers in its deepest sense to our Lord Jesus Christ; but we know also that the sun of righteousness refers not only to Him, but refers to the church which is His body, because the Lord applies it in the 13th chapter of Matthew in this way, in the parable of the wheat and the tares. You remember in connection with the separation of the wheat and the tares in the harvest of this Gospel Age our Lord said, "Then shall the righteous shine forth as the sun in the kingdom of their Father." So the sun of righteousness referred to here may be applied to our Lord Jesus Christ and the church who are joint heirs with Him.

"And the sun of righteousness will arise with healing in his beams." What does that mean? It is the great day of healing. It is the time of restitution spoken of by all of God's holy prophets since the world began. It is the time when creation will begin to cease groaning, because we are told by the Apostle Paul in the 8th chapter of Romans that when the sons of God are manifested then the groaning creation will be delivered, and the manifestation of the sons of God refers to this time, the time when our Lord Jesus and the glorified church will shine forth as the sun, and the healing beams of that sun will reach all the willing and obedient in that day; they will be the ones who will believe.

Now we want to notice next that the Lord's advent is that He might be admired in all that believe in that day. Let us note that the Scriptures speak of the church as glorified first; they speak of the church as being taken out of this world, the body of Christ, which is the church completed, entering into the great change, into the likeness of our Lord Jesus Christ, partakers of the divine nature, and then will come the fulfillment of this other statement, "all that believe in that day." The Lord's advent is that he might be admired in all them that believe in that day. Some will admire Him immediately when that day opens in connection with the great time of trouble which is to come, and which we are already in the beginning of. In connection with that great time of trouble we learn that some will admire, some are prepared sufficiently to appreciate righteousness and to admire and be glad of the fact that the Kingdom of God is established over



this earth of ours, and while they will not understand for sometime what the purpose of the establishment of that kingdom is, they will be glad of the great change which will come at that time in the transfer of the sovereignty of this earth from the present rulers into the hands of our Lord Jesus Christ and His glorified joint-heirs.

The Apostle states this in another way as we have already quoted in the 8th chapter of Romans. He refers to it as the time when the creation will be delivered. By creation we do not mean the inanimate creation, the trees and the rocks and the hills, as some of our dear friends interpret this Scripture, but it is the creation that the Lord spoke about, -- evidently not of its own will, but by reason of Him who has subjected the same in hope. It is mankind groaning under the curse of God. They will be delivered at that day, and it is stated by the Apostle Peter in the 3rd chapter of Acts, as the "times of restitution," and these times of restitution were spoken of by all of God's holy prophets since the world began.

Now another thing that is stated in the text is that the Lord's advent is to destroy them that acknowledge not God, and who obey not the gospel of our Lord Jesus Christ. Some of our dear friends, in noting the object of the second advent, have taken this Scripture, as well as a few others, and have stated that the object of the second advent is to deliver the church, that it is to deliver all of the Lord's people who have become His in the present time, but it is to destroy all others, and to destroy everything else. That is the interpretation given by some of our advent friends, and this Scripture is applied in that way. You see if they could only understand the fact that the day referred to here is not a literal day of 24 hours, and if they could understand also the fact that Jesus Christ gave Himself a ransom for all, they would of necessity begin to look into the times and seasons of God's plan, and would discover that the Lord had appointed a particular time when he will enlighten all those who are not enlightened in the present life, and that time will be the time of restitution. So the Lord's advent is to result finally, before the thousand years are over, in the complete eradication of evil in this world of ours, so that the earth will be full of the knowledge of the Lord as the waters cover the sea; and not only that, for that will be to a large extent in the very beginning of this day; for in connection with the introductory scenes of this day we read in the Scripture that all the false religious systems of earth will be destroyed, and the knowledge of the Lord will begin to fill the earth as the waters cover the sea, and before that day is over all those who are willing and obedient to the requirements of God, to the best of their ability, will be brought up into a condition where they will be able to stand any test which can possibly be applied to them. So there will never occur again an incident like that which took place in Eden -- no other fall; for the willing and obedient of mankind, those who will use the means which the Lord will place within their reach, will have the privilege of going up, up to restitution, to be restored back to perfect Edenic conditions, and then the test will be applied. And when that test is applied, all those who stand that test (and all who have had these privileges may stand the test if they will, if they have used the privileges as they should) will constitute a sufficient number to fill this earth, and the will of God will be done on this earth even as it is done in heaven; and not only that, but this earth will be brought into the condition which was typified in the home of the first man -- it will be made like the Garden of Eden. Eden was a place perfectly adapted to a perfect man; there was everything in it which was calculated to perpetuate the happiness of a perfect man. And you remember in Eden it was also calculated to perpetuate life. so in this restored Eden, which will be accomplished only at the end of this thousand years, this earth will be like that Garden of Eden. May God hasten the glad day; and we are glad, dear

friends, to know that that day is already being ushered in; we are already in the dawn; and the reason why we are enjoying this wonderful favor of understanding these blessed truths of God is because we are in the very dawning of that day.

Now I want to notice in connection with the introduction of this day that the Lord's advent is not to be as is generally understood. The Apostle in writing to this same church at Thessalonica tells us that the Lord's day will come in as a thief in the night; and we have our Lord Himself, stating in the last message which He gave to the church, in the 16th chapter of Revelations, the fact, "Behold I come as a thief." So that the advent of our Lord Jesus Christ will not be as generally understood by the church systems of to-day. We have, for instance, one body of believers who think that when our Lord comes he comes to destroy everything and everybody, except those who have become His people during this age. These same people believe that when our Lord comes back again He will come in a body of flesh, descending down the sky in the sight of all mankind. This is what is generally believed by professing Christians to-day. But we want to say that this is not the way our Lord Himself taught that He would come; and this is not the way that the apostles taught that He would come; but "the day of the Lord so cometh as a thief in the night.

Now, for instance, our Lord was asked the question on one occasion, you remember, on the Mount of Olivet, as recorded in the 24th chapter of Matthew, 3rd verse: "What shall be the sign of Thy coming and of the end of the world?" If that were the question asked by the disciples it would be very difficult to find the answer in the words of our Lord which follow in that discourse. But that is not the question; it is a wrong translation. Let me call attention in the first place that the word world there does not mean world as it is generally understood -- this earth. And then another thing, the word that is rendered end there is from two Greek words, one a derivative of "telos" meaning end, and another, "sun" meaning with, or, together. The proper translation, or a proper understanding of that text would be this: the consummation of the age. In other words, the over-lapping period of the ages. You remember that the Jewish age over-lapped the Christian and this expression, "the end of the age," refers to the over-lapping period of the Christian Age and the Millennial Age, or that day which we have referred to.

Now the question is, What shall be the sign, not of thy coming in the over-lapping period of this age, but, What shall be the sign of thy presence? It is a very difficult question. How do you know that is the question? We know it because we go to the original language and find this Greek word "parousia," meaning, according to all Greek lexicographers, presence. So the question is, "What shall be the evidence, or sign, of thy presence in this over-lapping period of the ages from this age to the next?" If that is the question, we would naturally expect to find an answer of our Lord in the same discourse. And so we will first find His answer as it applies to the world. Did our Lord teach in His answer to this question that at His second advent the whole world would see Him? Let us see. In the 38th and 39th verses of this 24th chapter of Matthew we have these words, which are a partial answer to this question: "As it was in the days of Noah, so shall it be in the days of the Son of man"; or as it is rendered, "At the coming of the Son of man" -- in the presence of the Son of man. As it was in the days of Noah so shall it be in the presence of the Son of man. Well, how was it in the days of Noah? As it was in the days before the flood men were eating and drinking and marrying and giving in marriage. Is that the sign? Is that the evidence whereby the Lord's people who have come to see that He will come as a thief in the

night are to know that He is present, because men are marrying and giving in marriage? Why, no, of course not, because that has been going on all the time. The significance is not in that expression. Notice that men were marrying and giving in marriage, and knew not until the flood came and took them all away, so likewise shall it be in the presence of the Son of man. How accurate this answer is, that the world will know nothing about it, that they will be going on just as they always have been, and everything will be going on, so far as the world sees it, as it always has. And the Apostle Peter in the 3rd chapter of his second epistle, brings out this same thought, that in the last days there would come scoffers, saying, as in the common version rendering, "Where is the promise of His coming?" But the Greek rendering is, "Where is the promise of His presence?" And you see the significance of it, for they say, "Since the fathers fell asleep all things continue as they were from the beginning of creation," etc. That is just what our Lord said would occur, did He not? Did He not say that men would be eating and drinking, and be about their usual customs, and everything would be going on as usual, so far as they knew, and they would have no consciousness that the Lord was present, and men would scoff at this and say, "Where is the promise of His presence? We cannot see anything to indicate that our Lord is present."

The question naturally arises then, if our Lord is to come that way, what kind of a being is our Lord? Is our Lord a human being? We thank God there was a time when He was; we thank God that in His pre-human existent condition He was a heavenly spirit being, and the Father's only begotten Son, the One whom the Father loved to honor, the One who, in the development or in the unfolding of God's plan, in the institution of that plan, was chosen to be the ransom sacrifice for mankind; and in order that He might be a ransom, in order that He might be a corresponding price we read that He underwent a change of nature and became a human being, as we learn in the second chapter of Hebrews: "We see Jesus, who was made a little lower than the angels for the suffering of death, crowned with glory and honor; that He by the grace of God should taste death for every man." That was the purpose for which He was made flesh. We read concerning our Lord now that He was not raised to fleshly conditions, but that He gave His flesh for the life of the world, and was rewarded for it with a new creation which began at Jordan when He consecrated Himself to the will of God, and which developed during the three and half years of His ministry, but which had nothing to do with the ransom; it was that new creation which was raised up and transferred to a divine body like our Heavenly Father's. And our Lord now has a body like the Heavenly Father, in possession of the divine nature, immortality. And so He will come back in this way. But we read in the Scripture that no man can look on immortality. You remember the statement in the 6th chapter of 1st Timothy, where our Lord Jesus is referred to and called the "Blessed and only Potentate, King of Kings and Lord of Lords, who only hath immortality [of course the Father excepted] dwelling in the light that no man can approach unto, whom no man hath seen, nor can see." So we want to note here that not a single member of the church of our Lord Jesus Christ, to say nothing of the world, will ever see the Lord until he undergoes a change and is made like Him. Secondly, our Lord when He comes, if He should come manifesting His glory, the glory of His presence, the effect upon mankind would be to strike all down dead. The Apostle Paul got just one glimpse of that glory, and he was stricken to the earth and was blinded and never fully recovered from it. Doubtless that was the thorn in his flesh.

So our Lord is not coming back as a human being. He gave Himself as a ransom for all. It would be taking back the price if He should come as a human being. But He is coming as a divine, heavenly, spirit being, in whom the Father hath confided the carrying out of all His plans and purposes -- and it would defeat these purposes should He manifest His glory. So when our Lord comes back again, the fact that He is present will be made known gradually, and thus He taught in the 24th chapter of Matthew. You remember He stated in the 27th verse, "For as the lightning cometh out of the East, and shineth even unto the West, so shall also the coming of the Son of man be." Some may say, Yes, that is true, it will be as quick and as sudden as a flash of lightning. But that is not the thought at all. The word lightning here is from a Greek word that is used at least one other time by our Lord, and is translated "bright shining." And it is in connection with the bright shining of a candle in the 11th chapter of Luke where the same Greek word is employed. So then the thought is not a lightning flash, but it is the bright shining from some light. In this instance it is not the light of a candle; as the lightning shineth forth from one part of heaven unto the other part, it could not be a candle. Well, what was it? We answer, the sun, of course, for the sun rises in the East and sets in the West. And what was the presence of the Son to be? To be made known gradually. To whom will He make known the fact of His presence first? We answer that all Bible history has taught us that He makes everything known to His people first; so the fact of the presence of the Lord will be made known first to the church. We are not to understand, though, that it will be made known to them all at once; it will be made known gradually, just as the sun rises. Those who are up early in the morning are the ones who see the sun come up, and the time will come when all will know it, all will have discovered it; and when the Sun of Righteousness shall have arisen with healing in His beams, when the church has been taken out of the world, then all the world will know Him. And that is brought out in that statement of our Savior when He said, "As it was in the days of Noah, so shall it be in the presence of the Son of man;" men were eating, drinking, marrying and giving in marriage, and knew not until the flood came and took them all away.

Now the flood in Noah's day was a type of what? A type of the great tribulation which is coming upon this world in connection with the overthrow of present conditions, preparatory to the establishment of the Kingdom of God. And it will be in connection with the great time of trouble, and in fact that great time of trouble is designed of God to make known to the world one thing, at least, and that is, that the old things are passed away and that God's Kingdom is then established over the earth.

The fact of His presence will be made known gradually. It will be made known to the church first, as the Apostle says, "Ye brethren are not in darkness that that day should overtake you as a thief; ye are children of the day? How will the church discover it? We answer, through the sure word of prophecy, which the Apostle Peter tells is as "a light which shines in a dark place until the day dawn, and the day star arise in your hearts." The evidences and signs of our Savior's presence tell us He will be seen where? In the heavens. That is, the evidence of His presence will be seen in the heavens. What heavens? Will it be the literal heavens above us, the skies, or among the stars? Will we look there for the evidences of our Lord's presence, "his coming"? No, dear friends; the symbolic heavens are referred to here, and our Savior tells us to look for evidences of His presence in the heavens. The symbolic heavens, then, are what? We answer so far as it applies to things here in this world of ours, it refers to the ecclesiastical systems, the religious systems. The signs are to be seen among the religious systems of the earth -- "the

powers of the heavens shall be shaken." Well, what do we see to-day? Do we not see the powers of the symbolic heavens being shaken in connection with the shaking of the creeds and dogmas of Christendom? Then we read that not only the powers of the heavens shall be shaken, but we read also that the heavens shall be rolled together as a scroll. what does that mean? The federation of these ecclesiastical systems. Do we see anything of this coming in our day? We answer, Yes. And then we read in Peter's epistle, third chapter, that the heavens shall pass away with a great noise; that is to say, the present religious systems will pass away. Do we see any signs in connection with the evidences that are transpiring in our day that the symbolic heavens show indications of passing away? We answer, it seems plainly significant to all who have their eyes anointed with the eye salve.

Then, again, we will discover the fact of His presence by having the fulfillment of our Master's promise to come forth and serve His people. You remember what our Savior said in the parable in the 12th chapter of Luke: "Let your loins be girded about and your lights burning; and ye yourselves like unto men that wait for their Lord when He will return from the wedding; that when He cometh and knocketh, they may open unto Him immediately." Now note that when He cometh is one thing, and when He knocketh is another thing. Why does He use these expressions? Right in harmony, we see, with what we have found in other Scriptures, that His coming will be as a thief in the night -- invisible -- and the fact of His coming will be made known by knocking. And He says in that same connection, "Verily I say unto you, that He shall gird Himself." When? "When He cometh." What will He do? He will come forth and serve His people. Serve them with what? Serve His people with the helps that will be essential to keep them in the hour of trial as predicted by the Psalmist, -- "The Lord will help her right early in the morning." And what are these helps? Why, the understanding of His wonderful plan; the privilege of looking over into the future, and see what is to happen there; that the time of restitution of all things is near at hand. And all of these glorious truths have come to us through the agency which was predicted to be opened by the Lord; that the Lord would select an agency in order that His people might have the meat in due season.

But, dear friends, we are living in the time when the table is spread, and our Lord has come forth to serve His dear people. May we just feast on these precious truths.

In connection with this, you remember, in the 24th chapter of Matthew, 27th verse, it speaks of the presence of the Lord being made known as the sun beginneth to shine in the East, and shineth unto the West. You remember right in that connection he says, "Wheresoever the carcass is, there will the eagles be gathered together." We are very sure of this, that when our Lord would come back again He would fulfill His word, first, in making known through the sure word of prophecy, the light which shineth in a dark place to His people, those who are awake, the fact of His presence; and they will be the ones who will be able to benefit and be privileged to partake of this meat in due season. And, O, how precious it is, this food which the Lord has given us concerning the great plan of God, so that we can look back into the ages which have come and gone, and see that He has been carrying out all the purposes which He instituted in His plan before the foundation of the world! And we can see that in this Gospel age His great purpose was to take out a people for His name; and all the Scriptures which were once dark and could not be understood are plain now; as, for instance, it has become clear and plain to us what the Apostle James meant when he said, "Simeon hath declared how God at the first did visit the Gentiles to

take out of them a people for His name." We understand that applies to this Gospel age, the calling out of a people for His name, to be associated with Christ as His Bride, as the Heavenly King, under whose ministrations all the families of the earth will be blessed. And when this great work is completed, we find it referred to in this same Scripture. He did not say, "In this was fulfilled the words of the prophets," but "To this agree the words of the prophets." That is, it is in perfect harmony with all that the prophets have said respecting the restitution of Israel, and then He adds these words: "After this" -- after what? After He shall have taken out a people for His name, "I will return." That is the same one who went away, our Lord Jesus, will return. For what purpose? To build again the tabernacle of David which is fallen down and restore, or renew as in the days of old, that the remainder, or residue, of men might seek after the Lord. That is what is to come in the future. And this is the Lord's programme for this age in which we are living, and in the age which is to come; to take out a people for His name, and then the blessing of all mankind with the enlightening information of His blessed truth, in order that all may benefit by the proclamation of His purpose in that future age.

So, dear friends, we are right at the verge of a great change; we are now living right in the closing of this age -- in fact, the transition period of one age to another -- and the reason why we have these wonderful blessed truths served to us is, that we may be kept.

Oh, how can we praise God enough that He has fulfilled His word, and that He has come forth and is serving us with these precious, blessed truths!

May the Lord Jesus add His blessing, in our prayers.

Brother Williamson: Our hearts are overflowing as we realize God's unbounded blessing to us and to all the families of the earth. As you have been enjoying the precious word of truth that has been presented to you by dear Brother Streeter, the dear friends who have not been able to gather into this service -- probably 300 of them -- have been having a very blessed time on the first floor. It has been one of the most precious experiences of the whole convention. As our hearts have been overflowing with the love of God, and manifesting to one another His love, downstairs the overflowing has been making itself manifest also.

In many respects it seems too bad to bring this day's blessed experiences to a close, but we know that we must have rest and refreshment for what the morrow shall bring forth to us.

**SUNDAY MORNING, SEPTEMBER 1, 9:30 A.M.**  
**Praise and Testimony Meeting led by Pilgrim Brother Bohnet.**

Brother Bohnet: It may be interesting to the friends to know that in the photograph taken yesterday there are, by actual count, 1,542 people. So we all have the honor of being present at the greatest convention the world has ever known -- viewing it from the Lord's standpoint.

Brother Russell is due here just about this time -- that is, if the train is on time -- and the arrangement is for his coming to this place at about half-past ten. Upon his coming into the room the pianist will play the first strain of No. 23, "Blessed be the tie that binds," etc., and we will ask the friends to please arise, and those who feel so disposed can wave their handkerchiefs at that time, giving Brother Russell the Chautauqua salute.

A Brother: When I came in town I heard there were three hundred convention people who were going to meet at the Pure Food Hall. I thank God that in our meetings the pure food is dispensed. I thank God that we have had it in this convention.

A Brother: I came to the convention to get a basketful to take home to some dear friends who could not come, and I now have to send and get another basket. Praise the Lord!

A Brother: This is my first morning at the convention, and I feel already as though I had the basket full. Pray for me.

A Brother: A few years ago I got in the habit of praying for wisdom, because I realized I needed it. My prayer has been answered. The Lord has seen fit to let me leave a very excellent position, and go into a position in which I have been so situated that I could not do anything else but study from seven to eight hours a day. I have been sitting beside a dying corporation, watching its last throes, and this has been a very excellent place for me. I have learned a whole lot, but it has cost me eight thousand dollars in cash, and this is the first time in four years I have been able to scrape together enough to get to a convention. But I am glad to be here.

A Brother: I thank God for having the privilege of meeting together with the Lord's people here, and to share with them the table of rich, pure food that the Lord has spread for His people at the present time. I want to thank God that He has permitted our dear Brother Russell to set in order His table that you and I have been feeding upon during this present harvest time.

A Brother: I thank the Lord that He has raised up Brother Russell, that, under the Lord's guidance, he has brought me into the full appreciation of the truth, and from this time forth I am going to enter into the harvest field until the end of the harvest, and carry the truth to others.

A Sister: Everybody up here in the gallery wants to say something to praise the Lord before this meeting closes. Won't you give us a chance to stand up and say "Praise the Lord, O my soul"?

Brother Bohnet: All that want to join in that praise to the Lord, raise your hands.

The whole congregation, both downstairs and in the galleries, raised their hands.

Sister Margaret Russell Land (Brother Russell's sister) arose and said:

Dear Brethren: I rejoice to be here; undoubtedly the Master, the Chief Reaper, is in our midst. How our hearts rejoice as we realize it is His spirit which illuminates each countenance and teaches us how to love one another! How true His words, "My sheep know My voice, and another they will not follow."

Since coming here many have inquired, "How long since you came to a knowledge of the Truth"? Upon my reply that it is "about thirty-three years," much interest has been expressed, with desire to learn something of the infancy and growth of what we term "present truth." After hearing, these have expressed great desire that still others should hear the same as a stimulus to their faith; so I trust that my testimony may be used of the Master to the blessing of some of His little ones.

Taking retrospective view, we see that more than 1,900 years ago the seed of Truth was planted. My mind pictures the seed-germ encased in the hard cover, representing the dark ages, which apparently hindered its growth, until "the due time," about the 16th century, when it sprouted. Laborers such as Zwingli, Malanthon, Luther, Calvin, Knox and Wesley were hired during various periods of its development to water this precious tree of promise. "In due time," we believe about 1874, the husbandman transplanted it into the open, that it might the better grow, blossom and bear fruit. At this stage He hired other laborers, having had several, we believe, in preparation; but He must needs have one who, despite "the burden and heat of the day," would prove faithful to His trust, even to the very end.

A few years prior to this period He anointed the eyes of a lad of 17 years that he might behold the errors and dishonoring doctrines being promulgated among God's true people. I rejoice to believe that later God's smile of favor rested upon him, my dearly beloved brother, according to the flesh, and that he was accepted as a laborer, not from necessity on God's part, but because this vessel lay in his pathway, empty and ready for service. This youth as a member of the Congregational church constantly inquired for explanations of various obscure passages of Scripture. His Bible class teacher, fearing that these unanswerable questions might make infidels of the other young men in the class, advised that the questions be referred to the pastor of the church, who after studying as to how he could harmonize the seemingly contradictory statements with which he was confronted and thus to prove the Bible to be God's Word by showing its harmony said, "Charles, I can help you very easily." And taking a book from his library said, "Read this carefully; it will satisfy your mind thoroughly on these points." He, very much pleased, took it home and began to read, but after reading one page he closed the volume and returned to the minister with the remark, "I shall need to see the book which precedes this one." "Why, what do you mean?" asked the minister. "I mean that this book starts out by assuming to be true the very things I desire to have proven to be true. I want the book which proves the Bible to be God's word and shows harmony in these Scriptures." The minister said, "I would advise you to stop investigating these things, for they were never intended to be understood." But he was met with the query, "Why then, did God place them here? If this is God's word, I believe He designed that it should be understood." Finally it was decided best to call a meeting of the Church session. Here was more perplexity for the youth; he wondering why it should be



necessary to call in consultation any outsiders; but he consented, and the Session was called in a special meeting for the purpose of discussing these perplexing questions and endeavoring to reconcile and prove reasonable some of the church doctrines. The men constituting this "Session" ranked high in professional and literary circles, one being a Professor in the Allegheny Theological Seminary. Charles met with them. At the close of the meeting the list of questions were returned to him with the admission that no satisfactory solution to these could be found. Later at a church meeting he requested a letter of dismissal, stating his reasons for withdrawing from church fellowship. About this time he had a very strange dream, and although he was not at all superstitious, not a believer in signs, dreams, etc., being extremely practical, yet this dream strangely impressed him. In his dream he seemed confined in an underground passage and stifled as with gases. Upon seeking an exit, he started toward a tiny yet the only visible light. He, however, found his progress impeded by prostrate bodies, seemingly dead, but upon examination he discovered they were merely stupefied with these same gases. He awoke, and feeling much impressed by this dream sought its significance, until finally this thought dawned upon him: Could it be that these were all stupefied by the same gases (doctrinal errors) from which he was awaking? Could it possibly be that God was awakening him first, and that his life's work was to awaken and help release others? He determined to seek further knowledge, remembering the Lord's words, "Seek and ye shall find, knock and it shall be opened unto you." From that time onward so devoted was he to the Lord's service that he spent all of his leisure time in mission work and conducting Bible studies, etc. About 1874 the true mode of Baptism and its import was discerned by him, and he and father, together with a number of others, including myself, symbolized our baptism into Christ by water immersion.

Later, about 1877, after attending a series of services held by my brother, a prominent Pittsburgh physician remarked concerning him, "I should not be much surprised if he should prove to be the youthful David who will yet slay with his pebble of Truth the great ecclesiastical Goliath." I feel I can truthfully say ever since those years he has been to me an example of self-sacrifice in every sense of that word and an inspiration, reiterating by his example the Apostle's words, "This one thing I do."

Sincerely and persistently he has pressed on to accomplish what he evidently felt to be his God-given mission. For thirty-three years I have watched his toilings up the hill of difficulty, for those were not days when warm, glad hearts welcomed him, nor words of "God-speed" heard to encourage him, as now; but days of scorn, for the Truth's sake, in which it looked foolish indeed to stem the tide of popular thought upon these subjects almost alone, turning the back upon all that seemed tangible, for that which at that time seemed so visionary. True, others came, and for a while rejoiced and assisted, but many becoming weary and relaxed their efforts. Though such discouragements came with "the burden and heat of the day," yet special grace and assistance also came, and the Master whispered, "Be not weary in well doing; in due time thou shalt reap if thou faint not." (1 Peter 2:12,19; also Hebrews 6:10.) Thus sustained and strengthened he continues until, behold! the tree blossoms, and its fragrance is wafted to the ends of earth, and others come "from every nation, kindred, and tongue" to co-labor in promoting the growth of Truth, which is so precious to us now!

"Paul may plant and Appolos water, but God giveth the increase." The Kingdom, the work, the laborers are all His, and to Him we delight to give the glory. We come to this convention 2,500

strong, testifying to the saving power of Him who over 1,900 years ago left us a legacy of love, with the assurance that if we suffer with Him we shall also reign with Him. As the reigning time draws very near, dear ones, let us "watch, fight and pray," taking heed that no man take our crown. Thus "we shall come off more than conquerors through Him who loved and gave Himself for us."

## **Sunday Morning**

At 10:30 Brother Russell came upon the platform and the congregation arose and sang one verse of Number 23, "Blessed be the tie that binds," etc., at the same time giving Brother Russell the Chautauqua salute. It was beautiful and impressive to see two thousand people, with happy and appreciative expressions on their faces, waving their handkerchiefs as a salute to our dear pastor, and as he responded by waving his own handkerchief, we are sure from the expression upon his face that he was deeply moved at this manifestation of welcome on the part of the friends.

At the conclusion of the singing, Brother Russell addressed the congregation.

Dear Friends: I need not tell you how much pleasure it gives me to be with you this morning. My heart has been with you for a couple of days. I have been thinking about your arrival and your pleasant time here, and remembering you in prayer, and I trust you have all remembered me also.

I am very glad to see so many here. Before I came, when some one saw the program made out and said, "Brother Russell, the friends will be tired to death; every session will be full. How will it be possible?" "Well," I said, "Brother, my expectation is that they will not all be able to get into the auditorium; they will have to take turns, and so, perhaps, they will not all be tired to death." So you see, I am not so much disappointed after all, dear friends.

Now, I hope you are going to have a very happy time -- I know, indeed, from your faces, as I look at you, that you are already having a happy time. It seems to me that those who are in the truth, those who have come to see, as we do, something at least of the lengths and breadths, and the heights, and the depths, of our heavenly Father's wonderful plan, can not help being happy. How could we be otherwise! No matter what may befall us, we have the assurance of the Lord's word, that all things are working together for good to them that love Him, to the called ones according to His purpose. If we ask ourselves what are some of the best evidences that we are amongst the called, we would say, one of the best evidences is that we have heard. You who have heard, must have been called. If you talk to a deaf person you will find that he does not respond, he does not appreciate; but when you talk to some one, and he gives evidence that he understands, and appreciates, and responds, then you see he has a hearing ear. So, when the message of the Lord goes forth, those who have ears to hear may hear. Our Lord, at the first advent, you remember, said to some in His day, "Blessed are your eyes, for they see; and your ears, for they hear. For verily, I say unto you, that many prophets and righteous men have desired to see those things which ye see, and have not seen them; and to hear those things which ye hear and have not heard them."

And so, dear friends, we are living in the harvest time of this Gospel age, in the time when special things are due, in the time when our dear Redeemer tells of His presence, when those

who have heard His knock through the prophetic Word -- those who have heard and opened their eyes, those virgins who have arisen and trimmed their lamps, those who realize the situation, those who have heard the voice of the Lord speaking peace and have realized the fulfillment of His promise that at His second coming those who would be ready, those who would be waiting, those who would be on the alert as faithful servants, He would come forth and gird Himself and be their servant, and cause them to sit down to meat and come forth and serve them -- are now enjoying these wonderful privileges. Now, dear friends, what you and I are hearing, what you and I are seeing in the Divine plan, what we are seeing of God's great arrangement for a few, that they should be partakers of the Divine nature, is so much more than we had ever surmised, so much more than heart had ever thought, so much more than mind ever appreciated, that when we begin to see what God has in reservation for them that love Him, our hearts are overwhelmed, and we say to ourselves, "Who spread for us this feast if it were not the Master Himself? Where did this message come from? How did it come that after eighteen hundred years we and our fathers, and their fathers, did not know that these things were in the blessed Word"? They were there just the same; we have no new Bible, but we have, dear friends, the light and the blessing that our present Lord gives us upon this Word of His, and this is what gives our eyes the blessing. Blessed are our eyes for we see, and blessed are our ears for we hear His Word in connection with all these things speaking peace to us, and showing us the way in which we should go, and what a joy it has brought into your life and into mine!

So, dear friends, what does it mean that you have been able to see, and you have been able to hear, when all round you, even though some of them seem to be nice people, and some of them very good people, have not heard? What does this say? It says: "Blessed are your ears for they hear, and your eyes for they see." And, indeed, by experience, those of you who have seen and heard, know in your hearts that there is a blessing such as you had never before had in all your Christian experience -- I care not whether it was for a day, or whether it was for twenty years. There are undoubtedly many in this room who were Christians for twenty years before they got the blessing of Present Truth, and I am sure that I speak the sentiment of every one of them when I say that all the past of their experience would not compare in any measure with one day, as it were, at the present time, with present enjoyment.

Now, dear brothers and sisters, what effect shall this have on our hearts? Shall we be puffed up as though we made this plan, as though it were ours, as though we had a patent right on it and might sell it out to others? No, indeed! It belongs to the Lord. We are blessed in receiving it, and we would like to see the same blessing extend to all others. We sympathize with those who cannot see, and those who cannot hear; fain would we give them the sight, fain would we give them the hearing ear, fain would we give those virgins who are sometimes asking for it the oil, but it is not in our power to give it to them. The Lord has ordained the means by which all should receive of the oil of the Holy Spirit, which will enable them to appreciate Present Truth; the terms and conditions are clearly laid down, and it cannot be obtained upon any other terms. God has arranged that matter, and the terms are these: that we must be fully consecrated to the Lord. And, therefore, when I find some dear friends inquiring about the way, saying, "Well, I am interested a great deal in this and want to know more about it, I think I am going to study this matter up, and see if I cannot see the same as you folks do," I say to them, "My brother, begin at the right place, it will be of no use to study expecting that you will understand merely from study; the study is necessary, but before your study can be effective study, you must make your

consecration to the Lord -- a whole-hearted consecration, even unto death. Those are the ones to whom the Lord has promised that they shall see, that they shall hear, that they shall appreciate, that they shall understand, and only those."

And so I trust if there are any here to-day who have not made a full consecration of themselves, and who are desiring to look into these things, as one brother said in this very city when we had our last convention here, "I cannot say I am quite a brother with you; I hear you call each other 'brother' and 'sister,' and I cannot quite call myself a brother, but since my wife is one with you in this way, and I am a Baptist minister and her husband, I guess I can call myself a brother-in-law" -- if there are any such here we would say that while we are glad to have a brother-in-law present, yet if there are any brothers-in-law here we want to say to you, don't expect that you will understand the deep things of God except by becoming full brothers. There is no other way; not that becoming full brothers means you will come under any yoke of bondage, for we have no yoke of bondage; the Son has made us free and we want to stay free, all of us. That is the spirit of which we are, that is the spirit of which we have been begotten; it is the spirit of truth, of which our dear Redeemer said, "Ye shall know the truth and the truth shall make you free." So the more you are getting of the truth, the more you are getting free indeed.

But there is a good deal of difference, dear friends, let me say, between being free indeed and cantankerous. We do not want to become cantankerous, but we want to become free indeed. Put the emphasis where it belongs; we want to be in sympathy with each other as much as possible, and live peaceably with all men as far as lies in us, and if there are any brothers-in-law with us we want to be at peace with them, and do not want to discourage them, but do want to tell them the plain truth, just as we would like to have them tell us under similar circumstances, that they cannot know the deep things of God except as they are begotten of the Holy Spirit and you cannot be begotten of the Holy Spirit except as you are first of all fully consecrated, after that you have believed. First comes faith as the foundation of everything, before we could be acceptable to God at all; then, as the Apostle says, the basis of that faith, which justifies us in God's sight, covers us as a robe of righteousness, and makes us worthy to come before the Lord at all, and be acceptable of Him through Jesus; then on the basis of that faith, on the basis of that justification, we present our bodies, as the Apostle says, living sacrifices, holy and acceptable to God, and our reasonable service. Our God has such a reasonable way, dear friends; everything about His arrangement is reasonable, beautiful, grand. So when we put ourselves in His power, we find that He deals with us as with brethren. How gracious is God's arrangement! Then He puts the matter in our own hands and says, "Here you have put the rope around your neck. You have already signified that you are consecrated to death, but I will leave the other end of the rope in your hands; you have control of it, and you can back out any time if you want to." And, dear brothers and sisters, those who have the right spirit do not want to back out; they want to be His clear to the finish; they want to be His beyond the veil in glory, honor, and immortality, and the wonderful things that God has in reservation for them that love Him -- for those who love Him not in the ordinary sense of the word love, not with selfish love such as people sometimes exercise toward their own cats or dogs, or children, or what not, but with the love that the Scriptures inculcate -- the love of God which passeth all understanding, that is deep, and broad, and generous, and that the Apostle emphasizes when he says, "The fruits of the Spirit are meekness, gentleness, patience, long suffering, brotherly kindness, love." These are the qualifications of heart that will make us more and more acceptable to the Lord, and make us

more and more fit and prepared for His presence, and for the work to which He has invited us.

Let us, then, see that we have this love, not the selfish love, but the generous love, the love that is willing to lay down and sacrifice self, and every earthly thing, according to the will of God, not according to the whim of some other person, or somebody else's idea, but according to your conscience as directed by the Word of God. God recognizes this individuality, this personality, and makes you responsible for yourselves. You are stewards of your talents, and your time, and your things, as I am of my talents, and my time, and my things, and each one of us shall give an account of himself. You do not give account as congregations; you do not give account as families; you give account individually. So we want to have that in mind, dear friends, that our wives, or husbands, or parents, or children, will not carry us into the kingdom; each one shall give an account of himself. Let us have, then, this relationship with the Lord, and this personal liberty, and this personal bondage also. We are bondslaves of Jesus Christ, as the Apostle says, bound to do His will, bound to do it even unto death; that is our covenant, and we are glad of it. We have not thought of backing out. Some one says, What is your pay? Well, no slaves were ever paid as we are paid, dear friends -- having in the present time the promise of the life that now is, and also that which is to come. Well, says the World, you Christian people have a lot of persecution, and difficulties, and tribulations, and in proportion as you faithfully walk in that narrow way, as you call it, you have a good deal of trouble. Well, we do have to admit that; there is no doubt about it. Whosoever will live Godly will suffer persecution; we have the Lord's word on it; we do not want to deny the truth. But what do we have in addition? We have what the whole world is looking for, and not finding, we have glory in our hearts, and we have the peace of God which passeth understanding ruling in our hearts, controlling in our hearts, and blessing our hearts, so that we are the happiest people in the world. It is in harmony with our experience that the happiest people in the world are the people in Present Truth. I do not know of any other people as happy; you will notice it in their faces, and in everything pertaining to them; and it is getting more so. I am pleased to tell you that as I meet the Lord's people, as I do every week, and, sometimes, as here to-day, for instance, and at another time in Ohio, and at another time in Illinois, and at another time in Pennsylvania, and so on -- meeting them at various places, and sometimes for the second, third, fourth and fifth time -- that I find a growth in grace; and that is what we ought to expect. We tell you, dear friends, that is what the truth is for. God did not give us the truth so that we merely should know more about Him and His plan than any other people. The Truth was given to sanctify, to separate, to make us wholly the Lord's. And if the Truth is not having that effect upon your heart and mind, it is not having its legitimate effect. And we are all in danger, too. As it was a blessed privilege to come into the light, and the light was intended to sanctify, we are to remember also that unless we abide in the light, and walk in the light, and are faithful to the light, and are good soldiers of the Lord Jesus Christ, we are in danger of losing it. The loss is gradual; at first it is so gradual we would hardly notice it; perhaps it would be permitted of the Lord that the Adversary should bring in some strong delusion, or some weak one that would seem strong, then we might lose everything that we might have, and be led astray in the error of the wicked, as the Scriptures call it: But the Lord has promised, and we remember His word, that He will not suffer those who are faithful to be tempted above that which they are able to bear, for the Lord knows them that are His, and He equally knows them that are not His. He not only knows those that are warm, and those that are cold, but also those that are luke-warm. Now, where will He know you and me? That is an important question for us. We are preparing for the great Feast, we are preparing for the great Convention that the Lord has been

telling us about, and our lives have all been shaped accordingly since we realized the truth. How is the work of grace going on? I am glad to say that, in a general way, it is going favorably. I hope that in each of your cases you can say, Yes, in my heart the work of grace has been going on favorably. We hope that will be more true by this time next year than it is today, and that you will keep going on from grace to grace, from knowledge to knowledge, and from glory to glory, until we shall see His face and share His glory.

### **Discourse by Pilgrim Brother John Harrison.**



While sitting this morning, dear friends, my own heart overflowing, as were also yours, I said there is but one reason why I might not wish that another should stand before you instead of me, and that is, that our Heavenly Father, by the blessed Holy Spirit, can use any instrument for the bearing of His message; and having by full consecration put myself into His hands, I said, He can use me this another time. And I praise Him that you have this blessed privilege of this glorious convocation in His name, in His service.

I want to call your attention this morning to a record in the 17th chapter of the Acts of the Apostles; beginning with the 22nd verse, we read to the close.

22. Then Paul stood in the midst of Mars' hill, and said, Ye men of Athens, I perceive that in all things ye are too superstitious.

23. For as I passed by, and beheld your devotions, I found an altar with this inscription, To the Unknown God. Whom therefore ye ignorantly worship, Him declare I unto you.

24. God that made the world and all things therein, seeing that He is Lord of heaven and earth, dwelleth not in temples made with hands.

25. Neither is worshipped with men's hands, as though He needed anything, seeing He giveth to all life, and breath, and all things;

26. And hath made of one blood all nations of men for to dwell on all the face of the earth, and hath determined the times before appointed, and the bounds of their habitation;

27. That they should seek the Lord, if haply they might feel after Him, and find Him, though He be not far from every one of us;

28. For in Him we live, and love, and have our being; as certain also of your own poets have said, for we are also His offspring.

29. Forasmuch then as we are the offspring of God, we ought not to think that the Godhead is unlike unto gold, or silver, or stone, graven by art and man's device.

30. And the times of this ignorance God winked at; but now commandeth all men everywhere to repent;

31. Because he hath appointed a day, in the which he will judge the world in righteousness by that man whom he hath ordained; whereof he hath give assurance unto all men, in that he hath raised him from the dead.

32. And when they heard of the resurrection of the dead, some mocked, and others said, we will hear thee again of this matter.

33. So Paul departed from among them.

34. Howbeit certain men clave unto him, and believed; among the which was Dionysius the Areopagite, and a woman named Damaris, and others with them."

We call your attention to the record in the 24th chapter of the Acts of the Apostles, verse 15, and we will read two or three preceding verses.

"But this I confess unto thee, that after the way which they call heresy, so worship I the God of my fathers, believing all things which are written in the law and in the prophets. And have hope toward God, which they themselves also allow, that there shall be a resurrection of the dead, both of the just and unjust."

Now, dear friends, these scriptures that we have presented this morning are the basis of the theme which has been assigned to us for discussion at this hour -- the subject of the resurrection of the dead, both of the just and unjust.

From our viewpoint we recognize death as the penalty for sin. Having hope toward God for all men, we see no other basis for that hope than by a resurrection. This doctrine of the resurrection we see, according to the lesson read, is the old doctrine -- one held and taught by God's ancient people, the Jews; one held to in some form or other by almost all nations, peoples, and kindreds of the earth, for even the heathen, while they do not realize from the Bible standpoint the doctrine of the resurrection as we see it, still hold for a future existence, still recognizing the fact that when death takes men out of the earth by some process or other, they will again return. We have not time this morning to discuss these various pagan and heathen superstitions along these lines, nor have we time at length to enter into the various views held by professed Christian people in regard to this wonderful subject which presents to us the only possible hope for humanity from any point of view at which their interests may be considered.

Many Christian people, and so far as I know, all men, recognize the necessity of a resurrection in order to live in the future. While this is true, there is also a great variety of opinion as to what the resurrection consists in. For example, the doctrine of natural inherent life, or immortality of the soul, would do away with the possibility of a resurrection but for the fact that those who hold that doctrine, and who also hold the doctrine of the resurrection, recognize two things. Knowing that the body dies, and recognizing that the spirit cannot die, they make provision for the

resurrection of the body. Hence you find written in the various creeds of the various organizations in connection with the Confession of Faith: "We believe in the resurrection of the body."

Well, now, I subscribed to that creed once, but I could not understand it. There are various views as to that proposition, and you will find, if you are among them, that they are discussing the question as to whether it is the same body that was born here that will be brought up, and through some process or other prepared to receive the spirit that has hitherto been dwelling apart from the body in glory, or torment, or some other place, and the whole arrangement prepared for a residence eternal in glory, or an abiding place forever in torment.

Now, there are a good many things in that connection I never was able to comprehend; for instance, as to how a physical body could be arranged for a home in glory; or how a physical body could be so constituted as to endure throughout all eternity the torments of fire. I was told it was so, and I must not inquire about these things too closely or I would go into infidelity, and that meant sure torment.

I am very glad this morning that that old nightmare of uncertainty, and of the possibility of such suffering for the larger portion of the human family, has completely melted away as the mists before the morning sun, and the glory of the Lord, and the joy of redeeming love, shines into our souls today having dispelled all the darkness and unbelief along those lines.

Our dear friends who hold to this doctrine of the resurrection of the body -- the same body that went down -- have another difficulty with which to contend. Counting the multiplied millions who have died, and added to these the millions of souls that are now living on the earth, they say these must all be brought up, and if any part of the body has been lost during the earthly pilgrimage, it must be restored, for if it be not identically the same body then it is not the same individual. That is the line of argument. The teaching I am speaking of now is not that which is held alone by people who have not had opportunities of knowing some things, but I am quoting from a man who, in his day, was recognized as of international reputation as a minister of the gospel, the late T. DeWitt Talmage, and he is only a representative of all other people of international repute as ministers of the gospel, for they all hold along the same lines. I remember to have read a discourse delivered by Mr. Talmage in Washington, D. C., some years ago, and he described the resurrection, as he alone was capable in his powers of graphic description, as being accomplished in a twenty-four-hour day. He described it as the dead being brought up from all over the earth in a twenty-four-hour day, the body being literally brought from the tomb -- that which went down; that the limb that may have been dismembered yonder must come here to this part of the body, and the two are united and made one again, which is as it was before. Not only so, but the same spirit must be brought from the spirit land and again re-enter this earthly tenement, and then be equipped for its position in eternity -- in glory or in torment. When I read this I said how could such a thing be? I did not say that with any lack of confidence in God. I believed that Jehovah God was able to do whatsoever was wise in His sight, but it did not occur to me as a wise thing for a God of order to have even a twenty-four-day of such confusion as that would create.



There is another view on this subject of the resurrection that goes along with it, with a little less trouble and friction, and yet their trouble comes from another source. They claim that the wicked will never have a resurrection at all, that only the good will have a resurrection, and that they will be brought up at the same time from whatever place they are to come -- to where? Why to a place in glory with Christ, taken up bodily. They will not need any resurrection. I do not know what they are going to do with the saints who have died. They evidently hope for them a resurrection. But the thought is, that after the saints and the righteous have been gathered out of the earth, the earth will be subject to a terrible heat that will completely renovate it in all its parts, and that after the renovation has taken place, Christ and his saints will descend to reign on the earth. Now the question is as to whom they are going to reign over. That proposition came up last winter in a series of articles written in the town where my home was. Somebody, it seems, had asked that question of the writer, and he said, I will tell you where the good will be protected, or rather I will let the Revelator tell you where the good will be protected while the earth is being burned over and renewed. He quoted then from the first verse of the 21st chapter of Revelations, which reads, "I saw a new heaven and a new earth." There, he said, is where the good will be preserved, the New Jerusalem suspended from heaven will be the home of the good while the earth is being burned over and renewed. Now that brother failed of one thing. And all who seek upon any other basis than the Word of God to account for any of God's works will find themselves always in trouble. I raised this question with the brother after he got through with his series of articles: Where are you going to be preserved while the heavens are being burned over? Why the various scriptures he quoted declare the same thing concerning the heavens that they declare concerning the earth; they were both to be burned, and the thing is represented as occurring simultaneously. There is always trouble when we fail to abide by the Word of Truth.

We have simply called attention to this in order that we might more clearly comprehend the truth when we get to it. We see that none of these theories are feasible, in harmony with the Word of God; we run against this bulwark and that bulwark whenever we depart from the record of the Word of God. Our text tells us that there is to be a resurrection, both of the just and the unjust. Why? Because it is our Heavenly Father's plan of administering the blessing promised to all the families of the earth; there is no other way possible. And why? Because the Adamic sin brought the curse upon the entire race of mankind. Now people are not always willing to recognize the whole truth in this connection. Death, as we announced in the beginning of our discourse, is the penalty for sin. There is no other penalty fixed. But our friends tell us that death means something besides what we say it does, that death does not mean death at all in some respects, but that it means life, life in a different condition. And yet I see no definition that will cover Jehovah's pronouncement against the man in Eden when he said to him, "In the day thou eatest thereof, dying thou shalt surely die" -- I see no other outcome but the going into death. But our friends tell us that death means separation. I used to argue as a Methodist preacher that death means separation; that physical death means separation of the spirit from the body, and that spiritual death means separation of the spirit from God, and that meant torment forever. But where do you find anything in the Scripture which intimates that there is something in man that cannot die? I have sometimes put it this way: If you will show me that some part of the man was not involved in the sin, then will I be ready to admit that there may be some part of the man that was not involved in the penalty for sin. But until you can show me a distinction between the "thou" that sinned and the "thou" that died, I cannot believe there is any difference; I think the whole being went into death. We have not time to discuss that subject further. I simply call your

attention to two or three Scriptures here which indicate the fact that the whole man goes into death, and that the only hope for that man is by a resurrection, as we will see from other Scriptures.

In the 49th Psalm, beginning with the 12th verse, we read, "Nevertheless man being in honor abideth not: he is like the beasts that perish .....Like sheep they are laid in the grave; death shall feed on them." What is more destructive than that? Then comes the golden lining of hope: "And the upright shall have dominion over them in the morning." There you have the hope. Who are the upright? "Gather my saints together unto me." Who? "Those who have made a covenant with me by sacrifice." These are they who are to have dominion in the morning. What morning? The morning of the resurrection, the glorious Millennial morning; the morning of the day for which the other days were made. Glory be to God, for it is dawning! It is even now within the range of our vision.

I call your attention to another record in the 90th Psalm: "Thou turnest man to destruction; and sayest, Return, ye children of men." What is more destructive to the human form and beauty than death? "Return, ye children of men." When Lord? It matters not, "For a thousand years in thy sight are but as yesterday when it is past, and as a watch in the night." In His own due time He will give the command to return. But by what authority will He command the return? By the authority of Him who was found worthy, not only of life in Himself, but had in his hand a ransom for His brother's soul.

Let us look at some other Scriptures in this connection. Come with us this time to the record in the letter of the Apostle Paul to the Roman brethren, chapter five, verse eighteen: "Therefore as by the offence of one judgment came upon all men to condemnation, even so by the righteousness of one, the free gift came upon all men unto justification of life." Now it is needless that we take time to stop here and define, and designate, that this one man in the first instance was the first Adam, and that this other man in the second instance was the Lord Jesus Christ, the second Adam; but some people say that in the Bible it does not always mean all when it says all. Did you ever meet any body like that? I met somebody like that just a few Sunday evenings ago at the close of a service in one of my pilgrim meetings. There came forward a brother -- I judged him to be a brother, he talked like a brother in some respects -- and he told me he was very anxious for the truth, and said, "I have been studying a little along the lines of your teaching, and I have not been able to get everything straight; I would like a little help, and want the privilege of a question or two." I said all right, brother, I will be very glad to help you in any way I can. I am sorry to say that he did not want the truth nearly so bad as he thought he did. He thought he wanted to instruct me along certain lines, for he started in like this: "You know the Bible does not always mean all when it says all." Well, I said, brother, then what does it mean? It does not mean some does it? He insisted that it does not mean all, and after talking with him a few minutes I took the text we have just now quoted to you: "As by the offence of one man judgment came upon all men unto condemnation." I said, brother, does that mean all? "Why, yes, that means all," he said. "Even so by the righteousness of one the free gift came upon all men unto justification of life." I said, Brother, does that mean all? He said, "No, that doesn't mean all." Then I said to him, Let me ask you another question; let us go to the record again. I want to know what this means: "Even so by the righteousness of one man the free gift came upon all men;" what does that "even so" mean? Does it not mean as truly as all were condemned in one

man, even so truly were all justified in one man? He did not have any answer. And he is not alone; there is a large class of people over the earth who read the Bible that way, and our hearts go out in pity for them, for they have much truth, and we read in the Scriptures that if they hold the truth in unrighteousness there is a fearful affliction awaiting them, and I fear many of them will have to come up through great tribulation, being unwilling to receive the truth in its simplicity and purity. God help them out of that dilemma -- who will come squarely up to the teaching of the Word of God to a certain point and then rather than surrender opinions that have been ground into them, call the Word of God in question, and say it does not mean what it says.

Now we want to look at this for a little while this morning, for it is a terrible thing, if true, that God's Word does not mean what it says. And we want to be sure, when we look at any point in the Word of God, that we see that it harmonizes with all others on the same subject. I remember on this point some years ago when I was in Sherman, Texas, meeting with a gentleman there who claimed to be an excellent Greek scholar, a teacher of the language. He came to me in my meeting and said, "Why is it you want to refer to more than one version of the Bible? Why can you not take one version and abide by it? I said, "Brother, if you will show me a version that harmonizes all of the Scriptures on each given subject presented therein, I will accept that version and not ask for another." He said, "Would you not accept the Greek text?" I answered, "I will accept a Greek text if you will show me one that harmonizes everything on each subject."

Now I call your attention to another Scripture on this theme of the resurrection. You will find the record in the fifth chapter of John's Gospel. The Master performed a miracle, and the people were astonished; they were looking on in amazement and he said, "Marvel not at this, for the hour is coming, in the which all that are in the graves shall hear His voice, and shall come forth." Come forth to what? "They that have done good, unto the resurrection of life, and they that have done evil, unto the resurrection by judgment." Now somebody says I won't take that as it reads, for in my Bible it reads damnation. In the Emphatic Diaglott and the Revised Version it reads judgment. It reads damnation in the King James Version; but did you ever notice that there are four other places in the same chapter where the same Greek word that is translated damnation in that verse is translated judgment? Now we want harmony, and there is a lack of it right here. We have it in the Diaglott, and we have it in the Revised Version; in all the places it is translated judgment and we believe that to be correct. Why? Because it fits so beautifully with the thought of the resurrection presented to us throughout the Scriptures, that God has in Christ Jesus provided for the bringing again of all the children of men -- bringing them again by a resurrection -- and the lifting up and enlightening of all the children of men concerning his purpose, his plans, his character, and the condition on which they may all have life. I think we are often times in difficulty at this point. We view the condemnation that comes to the race through the fall of our first parents, Adam and Eve, as the final condition of all who do not, during this Gospel Age, come into a knowledge of the truth and accept life in Christ Jesus.

Now, our dear friends who hold against a resurrection of the unjust forget the fact that they have never been enlightened along the lines of Gospel truth, and the thought which came to me this morning was this: The Adamic condemnation comes upon all men; there are none exempt; no man was ever found able to give a ransom for his own life; but the Gospel condemnation comes on no man until he has been enlightened and made acquainted with the Gospel plan of redemption. God will never condemn a soul who has not had the light and knowledge of the

truth. We call your attention to one or two Scriptures in that connection. We are told in Paul's first letter to Timothy, concerning this man Christ Jesus, that he gave Himself a ransom for all to be testified in due time. We are also told in the same chapter that God will have all men to be saved and to come unto the knowledge of the truth. Now that is our understanding of what the Lord Jesus Christ meant when He said in the 5th chapter of John that all should hear the voice of the Son of God and come forth, they that have done good unto the resurrection of life. Who are they? The Old Testament saints and the New Testament saints, all have had their trial day here and have been tested, proven, and found faithful; they will come forth to life -- the Gospel saints coming first to their glorified estate and exalted rulership with our Lord Jesus Christ upon the throne of His glory; the Old Testament saints coming forth later to perfect human conditions, and to be "princes in all the earth" for the administration of the earthly affairs of the kingdom under the direction and ministration of the Christ, Head and Body, the glorified church. They shall all come forth, they that have done good to the resurrection of life, and they that have done evil unto the resurrection by judgment.

Now somebody says I cannot quite accept that because my Bible says they shall come forth to a resurrection of damnation, and that means eternal torment, and you cannot make anything else out of it. Well look a little further into that text. Did you ever look at the Greek word there translated one time damnation and four times judgment? What is the Greek word? It is "krisis." What does it mean? It means a crisis. Well, what is a crisis? It is the turning point. To illustrate: You have had sickness in your home. You have known what it was to be under the shadow, as it were, of death itself. The physician has come and gone day after day, week after week. Your heart has been sad and your flesh weary with the watching, and for days there hovered over the home the cloud of death as the loved one seemed to tarry in the Valley with no decisive point indicating whether it would be life or whether it would be death. As the physician came and went day after day there was nothing in his countenance to indicate hope. But he came in one morning, and as he approached the couch of the sick one you saw in his face something that you had not seen for weeks -- something that gave you a little leap of joy in your heart -- an expression of pleasure. And he turned to you with his face all radiant and with a smile he says, "Well, the crisis has come." What is it? The turning point has been reached. The physical system has proven strong enough to wear out the disease. And, Oh, how glad you were as he turned and said, "Now all that is needed is careful nursing and the patient will soon be out." That is the position of this old world that for six thousand years has been under the dark cloud of disease and death, going down by multiplied thousands and millions into death. The crisis is about here; the turning point is at hand, and we are anticipating the day when the great physician will make the announcement and command, and they will come forth and He will take charge of them; and He will direct the nursing through the nurses that He has been developing and training through the centuries of the past. Glory to God for the prospect! And we know that the nurses will be all right for they have been under His direction, His immediate training, for this great work that is before us for the thousand years to come. Thank God for the fact.

But someone will say, With what body do they come forth? Now we have before us a thought which would require much more time to discuss generally than we will have at this service. Our understanding is that for all men a resurrection is indispensable in order to have any future life at all. I want to give one quotation on that. We all realize that the most hopeful people on the face of the earth are those who have hope in the Lord Jesus Christ, and we have greater hope for our

friends who died in Christ Jesus than we have for any other class of people we have ever known. If a man had no faith in Christ we do not see how he could have any hope in Him, and nominal Christendom today has no hope for a man who died out of Christ. The vast hordes of humanity have gone down into death without any knowledge of Christ, much less a hope in Him. But what are we going to do about those who have died in Christ Jesus? The Apostle Paul tells us in 1 Corinthians 15:14, "If Christ be not risen then is our preaching vain; and your faith is also vain." "If the dead raise not then they that are fallen asleep in Christ Jesus are perished." They are not in Heaven? No, they are perished, but for the hope of a resurrection. And we believe that they who have died in Christ Jesus, who have entered and successfully run the race for the prize of the high calling of God in Christ Jesus, have already been resurrected to their glorified estate with Christ in the glory of His Kingdom. But with what kind of a body? The same kind of a body that our Lord has -- a spirit body. His promise is that kind of a resurrection -- to be associated with Him in glory of His kingdom; to be made heirs of God and joint heirs with Him; "For I count not the sufferings of this present time worthy to be compared with the glory that shall be revealed in us." If it could be revealed in us it will certainly be revealed to somebody else. But who? Why to the whole creation that is travailing in pain together until now and who are to be delivered from the bondage of corruption into the glorious liberty of the children of God.

Now as to the ancient worthies, they will come forth unto life, but upon a different plane entirely -- upon the earthly plane. There are a good many things here pressing upon us that we would like to say; but let us look at that for a moment. Did you ever read carefully the 11th chapter of Hebrews? The epistle begins with righteous Abel, and continues with all the holy prophets, and then says that time would forbid that he mention all the others that might be mentioned in connection therewith; and what does he say of them? "These all, having obtained a good report through faith, received not the promise." Why did they not receive the promise? He gives a long list of sufferings they endured, and the privations they suffered, such as being compelled to wander about in sheep skins and goat skins, hiding in the rocks and caves of the mountains; enduring torture, such as being stoned to death, some of them sawn asunder, and they accepted not deliverance. Why? Because it meant the recanting of their faith, of going back upon their covenant relationship. Did they accept not deliverance because they wanted a home in heaven? Not a word about that. They accepted not deliverance that they might obtain a better resurrection. I remember the first time I ever notice that record; my heart almost stood still for a moment. I had never noticed it until after I had come into Present Truth. What is the better resurrection? It is not the best. Any kind of an awakening from the tomb would be good, would it not? The great mass of humanity will come up on the old plane of sin and degradation upon which they went down. That will be good, will it not? Yes, because there is going to be a highway opened up and they will be trained to go up that highway until they attain perfect human conditions. That is a good resurrection. But it is a better resurrection to come to perfect human conditions at once, is it not? -- rather than have to go up all along the toilsome way of education until it is attained? Well, that is the better resurrection -- the plane of perfect human conditions. So they will come forth to life at once, and we are told that they will be made "princes, in all the earth," to the glory of God, and for the great work of blessing all the families of the earth according to His promise. Yes, these will come up to life, and the others will come up to what? To human conditions, just as they occupied when they went down; they will come up in a state of sin and degradation, so far as the natural man is concerned; they will simply have their awakening, and then what? He will have them all to be saved. Saved from what? The present curse of death. That is the great

mission of our Lord Jesus Christ at His second advent -- to open the prison doors and let the prisoners out. Thank God for the fact; and He is not going to leave one unnoticed. I am so glad that everyone of them will have a release. Then what? They will come to a knowledge of the truth. And then what? They will accept it and live forever; or if they reject it, they will go down into the second death from whence there is never a hope of deliverance.

But with what body do they come forth? Our understanding is as suggested a moment ago, that they who are to be associated with Christ in the glory of His kingdom will have spirit bodies, just as He has, and we are told in the Word of God that there is a natural body and there is a spirit body; that the Lord Jesus was put to death in the flesh, but quickened in the spirit; that the first Adam was made a living soul, and the second Adam was made a quickening spirit; and this second Adam is the Lord Jesus Christ, and His church His glorified body, who are to quicken and lift up and bless the world of mankind.

Now our argument is attacked right here by those who say, "Well, if it is not the same body that went down, then it is not the same being." And then somebody says, "If the whole being is dead how are we ever going to be restored at all." I remember on this point that I have had people frequently ask me this question: "What becomes of the spirit when the body dies?" Well, what is the spirit? We have answered these questions frequently on this wise: That the word spirit is a very uncertain quantity to rely upon in any teaching. Why? Because the Greek word *pneuma*, translated spirit, is also sometimes translated wind, and sometimes air, and sometimes breath, and sometimes spirit. It is susceptible to all these translations. And the English word spirit is not wholly reliable. Why? Looking out of a window one day you see a man driving a team rapidly along the street; you say, That man is driving a spirited team. Again you see a young lady going along, and you say, There is a sweet-spirited young lady. You have used exactly the same expression in regard to the lady and in regard to the team. What do you mean? Why the team had a disposition to go, and the lady had a disposition to be obliging, kind and gentle toward everybody with whom she meets. Now it is not your disposition you are so anxious about, is it? And yet that word spirit is used right in that connection all the way through. What is it we want to know about? We want to know about our identity. What has become of it? Will I be the same on the other side that I am here? Will my friends, when they come up by a resurrection -- whether those who come up to life, or those who come up to judgment -- will they be the same beings they were before they went down into the grave? Evidently. We have a beautiful illustration of it in the person of our Lord Jesus Christ. They never recognized Him by His personal appearance, and evidently He did not have the same body; He was always recognized by some word or some act. And I believe that in whatever body my old father might be clothed when he comes up I would recognize him by certain forms or terms of expression, and by certain characteristics in him that are familiar to me, and that I never found in anybody else. And there is just as much distinction to be made in the characteristics of the individual as there are in the personal appearance. What, then, are we to conclude? Why, that God preserves our identity. Turning to Psalms 139:14, we find this record: The Psalmist there takes up the thought of the body, the individual body. Some think that he refers to the body of Christ. If that be true, it is all right; it is a body used as a figure representative of Christ. "I will praise thee; for I am fearfully and wonderfully made; marvelous are thy works; and that my soul knoweth right well. My substance was not hid from thee when I was made in secret, curiously wrought in the lowest parts of the earth. Thine eyes did see my substance yet being imperfect, in thy book all my

members were written, which in continuance were fashioned, when as yet there was none of them." I take that Scripture and put it along by the words of our Lord Jesus Christ when He said to those about Him, "Take no thought for the morrow," and "The very hairs of your head are all numbered;" and "Are not two sparrows sold for a farthing? and one of them shall not fall on the ground without your Father." That being true then, our members all being written in His book, if God is so careful of your being as to have the very hairs of your head numbered, the question is, "Can He forget you after you have lived to form a character?" Never. There is where your identity is preserved. It is in the resurrection morning that the identity of every son and every daughter of Adam is to be brought forth by the authority of Him who has this record of each in its identical place. Thank God. It is not an unreasonable doctrine, that of the resurrection. It is to my mind one of the most reasonable and one of the most pleasing of all Bible doctrines, while it is vitally important, and far more so, indeed, than that of any except the ransom sacrifice of the Lord Jesus Christ upon which it is based.

Go back to-day in memory two or three score years, and where do you go? Naturally to childhood days. Where? It matters not where, whether in this state or in an adjoining state, beyond the Rockies, or beyond the Atlantic, it matters not where those childhood days were spent; memory stops not at any object, or time, or space; it simply leaps over all and goes back in reverie around the days of childhood. What do you see? Why, you see everything just as though it were yesterday. You see father and mother, you see sisters and brothers, your schoolmates and associates, of your earlier life, and you look on them as it were but yesterday; you hear their voices, you see their faces, and you recognize their forms, their tone of voice, their color of hair and eyes, and even the disposition that characterized each, and your heart leaps with joy in anticipation, if you have faith in God, of meeting them again, some day, some time -- God's time. What do you lack? You simply lack the power to create, or you would gather them up and set them about you just as of old. Our heavenly Father who has ordained a resurrection of the just and unjust lacks in nothing. He holds in His infinite hands the power of calling again, and to establish again in their goings every member of the human family, and He is going to do it. How? By that man Christ Jesus, Head and Body, whom He hath ordained for the great and glorious work.

I think the most complete and perfect illustration of this doctrine of the resurrection I have ever heard, I received from my good Brother Henderson in Decatur, Ill., some years ago. He related this incident to me: A friend of his had lost his father; he had a phonographic record of his old father's voice. He prized it very highly. But it was a very common, cheap, wax record, and he knew it would not last long if he used it, and even the elements would soon destroy its usefulness, and it was not of any value except as he could use it anyway. In his anxiety he wrote to Mr. Edison, or to one of his establishments in the East, to know if he could do anything for him. The reply came back: "I must first see the record before I can tell whether I can do anything with it or not." The record was packed and shipped. On examination at the factory it was found to be in perfect condition. What did they do? They put it in an encasement, using plumbago as a moulder uses sand-mold, then using sand, and having it thoroughly packed and secure, it was subjected to a heat of sufficient intensity to melt that wax out completely. Where is the record of the old gentleman's voice? Lying there in the puddle of wax. Then what did they do? They took the more modern material used and poured it into that mold, and when it had sufficiently cooled it was slipped out, put into the instrument, and there was the old gentleman's voice in its

perfection restored. Was it the same old body? No, there is the old body. It is a new body, but the same voice, the same record. When I heard that story I said in my heart: If man can invent an instrument to record the human voice, and then take that record and destroy it completely, and then restore it in a new and better and more enduring form, what cannot the infinite God Jehovah do when He gets ready! Glory be to God for the fact that not a single son back in the ages ago, or down around this present time, not a single one who will not be remembered by the great High Priest, when He comes with His Bride associated with Him, and with those ordained of God for the accomplishment of the work. They will all be brought up and they will all have bodies just such as will be fitted for them, each in his place, and they will all, if they have not been brought forth unto life, be brought forth to a resurrection by judgment; and an opportunity will be given for each one to work up the highway, the glorious way that will be opened up. There will be no stones there to stumble, nothing to hurt or destroy, nothing to trip or turn to one side, but an opportunity will be provided for every member of the Adamic race to come up. But, dear friends, it is a fearful thought: If you have had the light here, if you have passed from under the Adamic condemnation -- the Gospel condemnation -- there is no more hope for life in the age to come.

God help us to recognize this glorious doctrine in all its beauty, grandeur and glory, to the glory of Him who hath loved us and given Himself for us, for His name's sake. Amen.

## **Labor Day! Rest Day!** **THE LABORER AND HIS HIRE.**

*Various Labors, Various Wages. -- Choosing Our Labor -- We Are Choosing the Wages Attached Thereto -- The Necessity for Wise Choice -- Some Egregious Mistakes -- Need for the Wisdom From Above in Deciding -- Divine Counsel in the Divine Word -- The Rest That Remaineth*

3 P.M. - Brother Russell spoke in the International Opera House, from the text, "The Laborer is worthy of his hire." (Luke 10:7.)



### *Labor Day! Rest Day!*

*THE LABORER AND HIS HIRE.*

*Various Labors, Various Wages.—Choosing Our Labor We Are Choosing the Wages Attached Thereto.—The Necessity for Wise Choice.—Some Egregious Mistakes.—Need for the Wisdom From Above in Deciding.—Divine Counsel in the Divine Word.—The Rest That Remaineth.*

*3 P. M.—Brother Russell spoke in the International Opera House, from the text, "The Laborer is worthy of his hire." (Luke 10:7.)*



As tomorrow will be celebrated as Labor Day, and as the Lord's calls are to those who labor and are heavy laden, it will not be inappropriate for us to consider the subject from the Scriptural standpoint. While the Scriptures do not lay down a fixed rate of compensation for labor, they do



indicate both in the Old Testament and in the New, as in our text, that labor should have its reward. And the word "hire" in our text seems to carry with it the thought of a bargain or contract between the laborer and the employer, which should be lived up to on both sides. From this point of view all that anybody gets for his laboring is his food and raiment and shelter, luxurious or otherwise. But from another standpoint none should labor for these things alone. In order to happiness there must additionally be a hope of improvement, of betterment. Whoever labors hopelessly, dejectedly, is worthy of our commiseration and needs our assistance that he may enjoy life at least a little. It may safely be set down that the hopeless life is a joyless life. It may also be safely concluded that the hopeful are the ambitious, and that the ambitious are the progressive workers of the world in all departments of industry. Here then lies the difficulty with the vast majority of the race -- hopelessness, stupidity, ignorance, blind them to any better prospects, and their toil therefore is doubly weighty upon them and the supply of their daily needs is proportionately disesteemed as an unsatisfactory wage for their labor. It is the hopeful and ambitious that are courageous and successful -- and they are a small minority of the whole.

Since, then, the hopeful are the happy, all true philanthropists will be glad to encourage hopefulness in all of his fellow creatures. The bright, intelligent eye speaks to us of hope, whether we see it in the workman, in the merchant, in the lady or in the housemaid. One is hoping for domestic happiness with his or her family, another hopes for name or fame or wealth, and all of these may properly be counted in as part of the laborer's wage and should be sought and appreciated and cultivated.

But some may say, I had hope but it is crushed out, it was killed. My business prospects were seemingly good at one time, but they have all been blasted. Another remarks, I have lost hope of any advancement in my trade; others brighter than myself are far ahead of me; it must be mine to plod along hopelessly. I could long for the end of life's journey were I sure that it would be better. These hopeless conditions apply to three-fourths or more of the adults of the world and of the remaining one-fourth the great majority will ultimately reach the same despair before they die, as comparatively few really attain to the earthly hopes and ambitions and prospects they set before themselves.

### **The Laboring and Heavy Laden**

Of all the books in the world the Bible is the one which enters sympathetically into the conditions of the race and offers cheer and comfort to the hopeless classes We have already described. It addresses itself primarily, not to the ambitious and hopeful, but to the laboring and heavy-laden and despairing. And to as many as hear and hearken to its voice it brings rest, peace, a new hope. But why does not the Bible especially address the hopeful, the ambitious, the progressives? Ah! it is because these have little or no ear to hear the divine message so long as their earthly hopes and ambitions are so bright and glorious before them. It is when these earthly hopes become blighted that they get the ear to hear the message from "Him that speaketh from heaven," saying, "Come unto me, all ye that labor and are heavy-laden (despised and grief-stricken), and I will give you rest. Take my yoke upon you and learn of me, for I am meek and lowly of heart, and ye shall find rest unto your souls." (Matthew 11:28,29.) Thus it is that the Scriptures everywhere declare that amongst those responding to the Lord's call in this present time not many wise, not many great, not many learned, not many rich are called, but chiefly the

poor of this world, rich in faith. The rich, learned, wise are the hopeful, the ambitious, the progressive of the present time, who feel not their need of sympathy and direction and aid. They see their own way or think that they do, and are following that which they believe will bring them the greatest joy -- the prosperity which they covet, name, fame, earthly ease, luxury, etc.

When our Lord declares that the laborer is worthy of his hire he expresses a general principle of justice. There are two great hirers or employers into whose service mankind may go -- God and Mammon -- and each one who hires out should properly consider the wages offered. Mammon makes great professions of what it will give, honor, dignity, wealth, etc. -- all things of the present life; it has nothing to promise as respects the future. On the other hand God is now inviting some to become His servants, and He makes very plain the terms and conditions, present and future, of those who shall accept His service. He tells them that to be His servants will cost them the renouncement of the pleasures of sin. More than this it will cost self-denial even in respect to things not sinful. It will also bring against the Lord's servants more or less of the animosity of the world and of the great Adversary. "Marvel not if the world hate you; ye know that it hated me before it hated you. He that would be my disciple let him take up his cross and follow Me." Here are some of the distinct propositions of the Lord respecting the wages that will come to those who will enter His service -- they must endure hardness as good soldiers of the Lord Jesus.

But must they serve to the extent of sacrifice and without compensation? No! The Lord has promised compensation -- that He will provide the things needful as respects the present life, though He in no wise engages to give more than bread and water -- whatsoever is more than this is that much more than the contract between God and His servants. But He does promise more in the way of hope. He promises that now, in this present time, His servants shall have in their hearts the peace of God which passeth all understanding. He promises further that the difficulties and trials of life shall constitute to these supervised experience under divine discipline and care, which will work in us a development of character deepening and broadening our hearts, and enabling us to appropriate more and more the peace of God and the love of God and the character of God in our thoughts and words and doings. But, more than this, God gives to those who accept His invitation most glorious hopes respecting the everlasting future. He points out to these that the present life is but a schooling period anyway, and that to the faithful alone eternal experience remains, an eternity of rest, an eternity of joy, an eternity of divine favor and blessing. More than this, the Apostle declares he has given us "exceedingly great and precious promises -- that by these we might become

### **"Partakers of the Divine Nature."**

It is when the Lord's servants begin to get a glimpse of these exceeding great and precious promises that have to do with the coming eternity that they begin to realize in true measure the love of God shed abroad in their hearts. Thenceforth, so long as they maintain this attitude of heart, old things are passed away and all things become new -- they care comparatively little for the things of this present life, since their aims and objects now are centered in the glorious things of the heavenly kingdom. Instead of laboring for some petty office of an earthly kind, they now perceive that in accepting the Captaincy of the Lord Jesus they have become heirs with Him in His glory, honor and immortality, and associates with Him in His throne, His Kingdom, when it

shall have been established. Instead of laboring for riches of an earthly kind, that would so likely take wings and fly away, they have now learned of the true riches of character and of the divine blessings which are, as the Apostle explains, an anchor to their souls, sure and steadfast, entering into that which is within the veil. -- Hebrews 6:19.

It will be seen, then, that there are two general classes of laborers -- the world in general laboring for the things of the present life and having little knowledge and almost no faith in respect to the things of the world to come. Of these we have seen that the vast majority are in a comparatively hopeless and despondent condition. On the other hand we find a new set of laborers in the world, the followers of the Lord Jesus, composed of those drawn from the ranks of the broken-hearted and discouraged children of this world, servants of Mammon. These have received new hopes, new ambitions, new peace, new joys, which far transcend any that they ever previously had, and all that Mammon has to offer to its most successful votaries. They are still laborers, and indeed in some respects their labors may be as difficult as at any time in the past; but they have found the great Helper and have realized the meaning of His words, "Come unto me, all ye that labor and are heavy-laden, and I will give you rest." Their coming to the Master meant a great transformation of heart and of ambition, of motive, and they are continually being more and more blessed as they hearken to His voice and learn the good lessons whereby He prepares them for future glories, honors, immortality. A summary of all this is expressed in the words, "Labor not for the meat that perisheth" (John 6:27) -- the present life and its present transitory interests -- but labor for that which endureth unto life eternal. We hearken again and hear the same message through the Prophet of old, saying, Wherefore do you spend your labor for that which satisfieth not? Hearken diligently unto me, and eat ye that which is good, and let your soul delight itself in fatness. -- Isaiah 55:2.

### **"They Have Their Reward."**

But there is a great difference between being truly the Lord's servants and being such merely in an outward, superficial way. It is necessary to point out that, while Christians are numbered according to the census at a total of 400,000,000, the real genuine followers of the Lord are represented in the Scriptures as being only a "little flock" -- not many. And with this Scriptural delineation our judgments and experiences are in harmony, for truly we know of but few who are even seeking to "walk not after the flesh, but after the Spirit" -- to be "not conformed to this world, but to be transformed by the renewing of their minds" -- walking in the footsteps of Jesus, gladly sharing in the sufferings of Christ for the prospect of having ultimately a share with Him in His Glorious Kingdom. There have been true and false in every age, and hence what we are saying is not a reflection merely against our own conditions. In our Lord's day He called attention to the fact that very prominent amongst those professing to be God's servants were some who made long prayers for a pretense, who gave alms with a similar purpose in view -- of having honor of men, of being thought holy. Our Lord declared of them, "They have their reward" -- they get the reward which they were seeking, namely, the praise and approval of their fellow creatures. They were not really God's servants, but servants of Mammon, servants of selfishness, who had put on the livery of the Lord and were pretending to be His. They were seeking an earthly reward of Mammon, and that they got. Hence their labor getting its reward in this manner; they had nothing laid up for them as a treasure in heaven; they got what they were working for, and that was earthly honor of men. That there are many enrolled in Church

membership to-day of a similar class can scarcely be doubted, many who draw nigh to the Lord with their lips while their hearts are far from Him, many who are children of this world while wearing the garb of the children of the Kingdom, many that are tares, imitations of the wheat, the true children of the Kingdom.

Whatever we are, let us not be hypocritical; let us not think to deceive the Lord, who knoweth and readeth the heart, and who tells us through the Apostle, "His servants ye are to whom ye render service." (Romans 6:16.) If we are really living for the present life alone let us not pretend otherwise, but remember that an honest servant of Mammon is much more respectable from the Lord's standpoint than one who dishonestly professes to be a servant of the great King. Whatever we are let us be truthful -- we cannot deceive God; let us not deceive our own hearts. Let us be content then to be misunderstood by the world, misrepresented by the hypocrite class, if thereby we have fellowship with the Lord, and have the privilege of walking in His steps, and the glorious promise of by and by sharing His likeness as members of His Bride and sharers with Him in His Millennial Kingdom.

Our text applies to this feature of the subject, too -- the laborer is worthy of his hire. The hypocritical desiring the approval and smile of the world and the prosperity of this present time gets the reward sought in some measure at least, though not always. The god of this world cannot be relied upon thoroughly in regard to any promises. As respects the servants of God, all of these who will prove worthy by their faithfulness will find their God faithful and His word of promise sure -- faithful is He who has called us, who also will do for us exceedingly and abundantly more than we could have asked or thought. Our hire, then, we are to remember, is in this present life trials, difficulties, sacrifices as respects earthly things; but the divine favor and blessing upon our hearts, upon us as New Creatures, and our faith and hope beyond the veil, constitute the chief elements of our wage. Could all the servants of God from the humblest member of the Church of Christ up to and including the most honorably engaged in the public ministries of the Lord's Word -- if all these could but have in mind what constituted the wage, the hire that the Lord has promised them, there would be but comparatively little expectancy of great favors or strife therefore, but a contentment with the Lord's provision -- with a realization that He knows the things we have need of before we ask Him, and that He is both able and willing to give us the things most expedient for our welfare, the things which will help us best in the attainment of the exceeding great and precious promises which are the main part of our wage -- the portion most encouraging to us, most stimulating -- for which we really live, and on account of which all other things are to be counted as but loss and dross.

### **Labor to Enter Rest.**

The Apostle calls attention to the fact that those who have become the Lord's consecrated followers have by faith already entered into rest by trusting in the finished work of the Lord Jesus on our behalf, by realizing that through His sacrifices God has made provision for the forgiveness of our sins and our acceptance by Himself. This indeed gives a rest and a peace and a joy which the world could not appreciate, which the world can neither give nor take away. All this, however, is a rest of faith only and not an actual rest. The Apostle differentiates between this rest of the present time, into which believers have already entered, and that rest of the future which is in reservation for them that love God. He says of the latter rest, that remaineth for the

people of God -- "Let us labor, therefore, to enter into His rest," and again -- "Let us fear lest a promise being left us of entering into His rest, any of us should seem to come short of it." -- Hebrews 4:1,11.

Here then are the two thoughts respecting labor. In one sense the Christian ceases from labor when he by faith accepts the Lord Jesus. In a word, he accepts the fact that he was not worthy of eternal life, but that the merit of Christ has made up for his deficiency. No longer need he labor to do the impossible thing, for all that was on our part impossible has been done for us by the Redeemer, and is imputed to us who believe. The believer's reconciliation to the Father is affected through faith, by which he lays hold upon the work already accomplished on his behalf. But therewith the consecration of himself to the Lord begins a new work -- not a work of justification, but a work of schooling, a work of grace, a work of development of heart and of head and of talents in the service of the one who redeemed him and set him free from the slavery of sin and death. He has entered into a contract to serve the Heavenly Father with all his powers, and so surely as he remains loyal to the Father and His covenant he is guaranteed grace to help in every time of need (Hebrews 4:16.) It is for the consecrated believer, however, to demonstrate his loyalty by his works, by his endeavor to do the Father's will, and different degrees of blessings have been promised to the faithful overcomers and also special blessings to the still more self-sacrificing, styled the "more than conquerors." (Romans 8:37.) Both are to get eternal life, but the latter are to have it in association with the Redeemer as the Bride, the Lamb's wife and joint-heir in the Kingdom. Thus the Apostle says that by our labors in the Lord's service we are to "work out our own salvation with fear and trembling. Our labors will have to do with the grandeur of the salvation which will be bestowed upon us, for, as the Apostle again declares, the saved will differ as star differeth from star in glory."

Both of the classes of saved ones just mentioned must labor, must demonstrate their loyalty to God and to the principles of righteousness, by fighting a good fight of faith, striving against sin and laying down their lives for the brethren -- for the Lord's cause. Hence, as is declared, we must labor if we would enter into the rest which remains for the people of God. But this labor, as we have already seen, is a different one from that which the unjustified world is occupied in. Our labor is in connection with the Father's work -- "I must work the works of Him that sent me." (John 9:4.) We are not laboring for ourselves, but for the cause of the Lord, including the cause of all that are His. If any man after being justified through faith and after making a consecration to do the Father's will shall fail to labor in this manner, it demonstrates that he has not the proper appreciation of the Father's favors nor of his own consecration vow. Such will not enter into his rest -- such will be proving themselves at heart disloyal to the principles of righteousness for which God stands, and if disloyal to God and righteousness the only provision for them will be the Second Death. So, then, the better we understand the situation the more thoroughly do we concur with the Apostle's exhortation, "Let us labor that we may enter into His rest."

### **"God Will Not Forget Your Labor."**

Many of the Lord's children, realizing their own insufficiency and the Lord's greatness, realizing the small value of anything they can do to directly glorify the Lord or to promote the interests of His cause, are inclined to feel discouraged and to say within themselves, if not to others, When the Lord shall decide my case I fear that He will find no labor in service accomplished for His

cause -- no ground for saying to me, "Well done, good and faithful servant, enter thou into the joys of thy Lord." But we remind such that if they are doing with their might what their hands find to do they could not do more, and the Lord is not asking more than they are able to do. He is quite able to do the entire work Himself. But what He does seek in us is the loyalty of heart, the desire, the effort to serve Him and His cause of righteousness. We remind them that in connection with the very Scripture quoted, the Lord not only declares that He will reward the good and faithful servant but he adds, "Thou hast been faithful over a few things; I will make thee ruler over many things." The intimation is that none of the Lord's people have been or could be faithful over many things -- that only a few things are committed to any of us, and that the Lord is seeking merely to note our disposition and to reward us accordingly.

We remind these faithful but timid ones again of the Lord's message through the Apostle, saying, "God is not unrighteous to forget your work and labor of love which ye have showed toward His name, in that ye have served the saints and still do serve them." (Hebrews 6:10). And again He still more particularly shows that there are two classes of labor to be rewarded, an active and a passive. He says, "Call to remembrance the former days, in the which, after ye were illumined, ye endured a great fight of afflictions; some being made a gazing-stock both by reproaches and afflictions; and some becoming partakers with them who were so used." (Heb 10:32,33). Here we note the Lord's benevolence, in that He is willing to count as His servants and laborers to whom He will give a reward not only those who were actively in the conflict, sufferers for righteousness' sake, but also to count in with them and to reward with them others who, themselves suffering nothing, were loyal to the principles of righteousness to the extent that they stood with and acknowledged and upheld the cause of the Lord and those who were His, and who suffered for righteousness' sake. What a gracious arrangement we have here! It shows us that the slightest labor that we can perform in the cause of our Master will be accepted of Him and bring us a share of His ultimate blessing. With such inducements, who has a proper appreciation of the Lord and His goodness would not desire to lay down his life in His service?

The intimation of the Scriptures everywhere is that the Lord's people are to be active, "Instant in season and out of season," using time and talents in the Lord's service and to the Master's praise. They show us that the present life is all one of activity and labor, looking for the rest of the people of God in the future -- except that measure of rest which we have by faith, and which enables us to rejoice even in the trials and difficulties of life, and to even count afflictions as unworthy of consideration because of the joys of our faith. I exhort you, then, that we rest from all sin and from all attempts to justify ourselves, that as we have accepted Christ Jesus our Lord, so we continue to rest in Him, the rest of faith, and that we continue to labor to the extent of laying down our lives for the Lord and His cause, and that thus being found faithful as laborers we shall ultimately be granted a participation in the glorious honors of the Kingdom.

If there is any one power in the world that will make itself felt, it is character. There may be little culture and slender abilities, yet if there be a character of sterling excellence, it will demand influence and secure respect.

## **Overflow Meeting**

*at Natural Food Company's Auditorium, About Four Hundred Being Present.*

Brother Williamson: Well, dear friends, this is an overflow convention, and surely the spirit of the Lord is overflowing in our hearts. I rejoice to see it, and I am sure you rejoice with me. Surely the Lord is with us, to bless us and strengthen us as we are gathered together. It will be a great pleasure to us this afternoon to hear our beloved Brother Sullivan. I do not need to introduce him. We all rejoice that he is here, and are glad to know that we shall now hear from his lips the glorious message of the Word which he has to proclaim to us.



Brother Sullivan: Dear Brethren; I need not tell you that I esteem it the greatest possible blessing and privilege to be permitted to speak to you all upon this important occasion. I am quite sure that this audience is made up of "hearing ears," and I pray God that our meeting together may not be in vain this evening, but that it may be a blessing to us.

I was just thinking a moment ago that we will soon all see that Jesus has led us all the way; but we must not turn aside to the right nor to the left. Let us proceed in this narrow, straight way and look for the divine blessing to strengthen us. But remember this: The angels come and minister to us, not before the temptation, but afterwards – after you have stood the test. After Jesus had stood the test, He said, Get thee behind me, tempter. Then angels came and ministered unto him. And I will tell you, dear brethren, they will come every time. The most real thing in this world is God, and He is taking care of you and me; He is looking on to see what influences control your actions and mine. Will you remember that and carry the

thought with you, that in all of these trials and temptations, the blessed Lord is looking on and listening to see what you will say, and to note what things control your actions, and how you appreciate your privilege of being joined to him in this narrow way.

The subject to which I invite your thoughtful consideration to-day is:

### **Greatness -- From God's Standpoint.**

"At the same time came the disciples unto Jesus saying, who is the greatest in the kingdom of heaven?" (Matthew 18:1).

Bear in mind that Jesus answers this question. The first thing that impresses us at the beginning of this study is, the contrast between greatness as it is practiced by the world from Satan's standpoint, and greatness from God's standpoint. Greatness as revealed in the Word of God, and

as practiced by our Lord Jesus Christ, who is our example, is diametrically opposite to the teachings and practices of the world, which is under Satan's influence and control, and is being swayed by his mind, his spirit, his disposition. So at variance with the true standards of life has the world become, that it casts off and rejects that which God accepts and honors.

The prophet Isaiah pronounces a woe against those who practice the false at the expense or sacrifice of the true, saying; woe unto them who call evil good and good evil, that put darkness for light and light for darkness, and put bitter for sweet and sweet for bitter. As illustrating this point, note the following:

### **A Contrast.**

The two masters in matthew 6:24: "No man can serve two masters. Ye cannot serve God and mammon." Behold in the gilded parlors on Fifth avenue in New York, one of earth's queens, a devotee of mammon. She has wealth by the million, liveried servants, magnificent apartments, jewels, silks, wines, balls gardens, music, flowers, banquets, gay companions etc. -- with many heart-aches and groanings. But watch her, as she sits resting her throbbing temples upon her weary hands. Watch her as she thus sits scheming, scheming far into the night. The clock has struck twelve; again it strikes one, yet she lingers, scheming, scheming. What is she doing? Why don't she rest and enjoy life, for surely she must be happy. Oh, no! On the contrary, she is most miserable. She is a slave to mammon. She enjoys nothing. She only schemes and slaves and serves the god of this world. She is only seeking how to retain and increase her hold upon other society moths, who, bewildered like herself by the glare of mammon's brightness, are intoxicated by the spirit of Satan. She is only scheming how she may have them bow at her feet and thus gratify this Satanic ambition. Notice her as she spends a few feverish years and is then borne to the tomb unwept. The world calls this greatness.

### **The Scene Changes.**

Contrast in your minds with this a sweet maiden of twenty years. She has plain attire, beauty, health, a warm sunny heart, a happy face. She is one of heaven's queens -- the Lord's Bride.

She, too, poor soul, has human desires and wishes. True they are not many now; they were once, but now they have narrowed down to one -- just one. Listen to that sweet, earnest little prayer as she, too, sits leaning upon a table looking up -- listen! "Blessed Lord Jesus, may I have just this one desire: I have given up nearly all -- only this one remains. Father is gone, society is gone, all the school girls have forsaken me; I have not much money left; I am so tired; I have been going all Summer selling Millennial Dawns spreading the 'glad things.' Blessed Lord Jesus, may I indulge just this one hope; may I marry this one, who reflects so much of thy Spirit, and have a home, and settle down for just a little while?"

The tears (human tears, not sorrow's tears) are streaming down her cheeks. A halo of brightness covers her face. What is she doing? Listen! "Shall I with my own hand sever this last cord that binds the human heart to these earthly loves? Must I give up all?" She hears the Lord's voice in His Word, speaking (Matt. 10:37-39): "He that loveth father more than me is not worthy of me; and he that loveth son or daughter more than me is not worthy of me. And he that doth not take



his cross and follow after me, is not worthy of me. He that saveth his life shall lose it; and he that loseth his life for my sake shall find it." And again she hears the Lord saying, through His Word (Matt. 10-29): "Every one that hath left houses, or brethren, or sisters, or father, or mother, or children, or lands, for my name's sake, shall receive a hundredfold, and shall inherit eternal life." And as she listens to these words she reaches a conclusion. Hear her own words:

### **Her Conclusion.**

"The question is now entirely settled in my mind. The week has been a solemn one for me. I have been thinking, thinking, thinking. My heart was full. I told the Lord that I loved Him supremely, and that if any earthly love would call for affection which should be centered on Him, I would sacrifice it.

"My dear loving Father has shown me that it is a lack of faith to desire to lean on an arm of flesh; that He is abundantly able to care for me without human aid; and that the greatest and noblest earthly love would be selfish inasmuch as it would be pleasing self.

"I see this in a new light; personally I preferred to think I would be more greatly helped spiritually by marrying one who reflected much of the Master's Spirit; that under such circumstances I needed not to sacrifice this desire; but I realize now that my consecration is unto death, and that my human desires have no right to make any demands, or express any preferences; and that it is the things which are right in themselves that we have the privilege of giving up. Oh, the Lord has become so precious to me through this experience. How can I thank Him enough. The colporteur work seems more grand than ever, and a holier joy has come into my heart. I want to praise with heart and voice as I never praised before, and the gladness and the gratitude rejoicing to outpour."

This is greatness from God's standpoint. God calls it so and our hearts respond, Amen!

Greatness then is: 1st, that attitude of heart which prompts us to make a covenant of sacrifice at the beginning and, 2nd, that which does not hesitate to carry out the conditions of such a covenant, even unto death.

Briefly: Greatness means making a covenant, and keeping your covenant. Around these two points this discourse revolves.

We notice in the first place, that the disciples were judging that to be a part of the Kingdom of Heaven was to be great. Jesus admits this to be true, as He also taught elsewhere, saying (Matt. 11:11 and Luke 7:28): "Among them that are born of women there is none greater than John the Baptist; yet he that is least in the Kingdom of Heaven is greater than he." However, he proceeds to show that this greatness consists of two parts, or,

### **Two Elements.**

First: The choosing of the right, and secondly; the will-power or ability to follow up that choice - to bring their conduct into conformity with their covenant. The Lord admitted that they

possessed the first of these elements of greatness, else they would not have been His disciples. But as to the second point the Lord proceeds to give explicit instructions, saying; (1) "Ye must be converted and become as little children." (Vs. 3.) And (2) "You must humble yourself." (Vs. 4.) And (3) "You must receive these little ones as you would receive me." (Vs. 5.) And (4) "You must not ensnare one of these little ones which believe in me." (Vs. 6.) And (5) "You must not permit the most desirable things of this life to ensnare you." (Vs. 8 and 9.) "But (6) on the contrary you must be a sacrificer." These things dear as a foot, a hand, or an eye, to the flesh must be laid upon God's altar. All this requires much will power.

We note in the next place that the heart condition which prompts us to choose the right at the beginning, regardless of predominating influences, is one of the principal elements of greatness. This is admitted by the Lord, and is obvious to all the thoughtful. But on the other hand it is equally clear that all these right decisions are of no value except they have "power of will" to sustain them and execute them.

Our Lord's teaching in this lesson may be analyzed as follows:

### **Analysis.**

I admit that to be a part of the Kingdom of Heaven is, as you suppose, to be great; you are correct; I admit also that you possess some of the necessary elements of character, which is shown by your faith and consecration in becoming my disciples. But I call your attention to the fact that there is another element or factor in which you are seemingly deficient. This is will power. Your conduct is out of harmony with your covenant. mark well; it is not "will" to do as you prefer of which I am speaking, but "will" to control your own flesh with its affections and desires. You must be converted (turned) from Satan's and the world's way of seeking and proving greatness. The world's greatness is a false kind of greatness. Instead of being proud and self seeking, you must humble yourself as this little child. This requires will power.

To how many of us this same statement could be made today: "Your conduct, your thoughts, your words, your expenditures, your example, are not in harmony with your covenant."

Our Lord is then showing to us and to them that greatness consists of

### **Certain Elements of Character.**

The Lord in substance says, I would have you, and all who would come after me, to understand that true greatness, greatness from the standpoint of God, consists of certain elements of character, and not in power, or ability, to usurp, dominate and control.

These elements are easily discerned. They are faith and consecration, backed by a strong, unimpaired "will." These constituted the very essence of Jesus' character; and they are the very foundation of all true greatness. An unconsecrated life has no object, no meaning, but is only a weary round of duties and responsibilities; but for the consecrated to be living at the present time is sublime, full of meaning, full of interest.

## **What Faith and Consecration Are.**

Faith and consecration are faculties of the mind. (1) That which prompts us to lay hold of God and His promises as the chief good is "faith," and (2) that which desires to follow His leadings at any sacrifice and at any cost is "consecration." These lead us to choose the right regardless of predominating influences: At the present time the ruling influences are evil, are bad. Now it is easy to do wrong, and almost impossible to do right. Why is this so? Why does the Apostle Paul say, (Rom. 7:15) "The things that I would, I do not, and the things that I hate, I do" -- or practice. Because (verse 18) "in my flesh dwelleth no good thing." And he exclaims (Verse 24), "O, wretched man that I am; who shall deliver me from the body of this death?" So we see, dear friends, that the reason it is hard to do right now is because of the infirmities of the flesh, and because we wrestle not against flesh and blood, but against wicked spirits in exalted places, (Eph. 6:12), and against governments, authorities, and with potentates of this darkness. (Eph. 6:12 Diaglott).

This government is that of the "God of this world" (Satan) together with the demons or devils, the fallen angels, Satan being the prince of these, and of the world. (See 2 Corinthians 4:4; John 12:31, 14:30; 16:11; Eph. 2:2.)

## **Steps of Faith and Consecration.**

The taking of these right steps shows we have the right heart to begin with; but to follow this decision, or choice, faithfully unto death, at any cost of self-denial, suffering and weariness, requires much will power -- more than is necessary for any other thing. Greater is he who rules his own spirit (brings his will into full submission) than he who takes a city. (Prov. 16:32.)

You must be guided into this greatness. You have some of the elements necessary to begin with, but this is not sufficient; these must all be developed. (1 Corinthians 3:9.) The full immersion of your will into the will of the Lord is absolutely necessary at the beginning, and this must be followed by bringing your conduct, your thoughts, your expenditures, into harmony with your covenant. Therefore my instructions to you, and to all are: (1st) That it is not only necessary that we exercise faith, and take the step of full consecration at the beginning (which not many can do, most being like unto Esau), and, (2nd) that our wills must be kept continually immersed in the will of the Lord. And he is greatest, whose will, being least impaired, shall succeed in controlling the perverted, unnatural desires and ways of the world and the flesh. Just to the extent that you succeed in doing those things are you great. Not all can or will do this last either, for they promise more than they are willing to perform, and are broken off as branches of the vine. (John 15:2.)

## **The Question Brought to Jesus.**

Jesus' disciples had just had a quarrel as to who was greatest. (Mark 9:33.) They had now brought the question to him. His answer was: "To be truly my disciples (learners) is to be great." Nothing in this world can add any luster to that. That is the greatest possible honor. But, mark, you must learn of me, not of the world. Follow my example, not Satan's. Walk in my footsteps,

not society's, not mammon's, not your parents'. You must mark my conduct, and govern yourselves accordingly. "Let this mind be in you which was in Christ Jesus." (Phil. 2:5.)

Holding firmly the thought that Jesus is our example, let us turn our attention for a few moments to a study of

### **Jesus' Mission.**

Jesus had a mission; He knew it. It was constantly before His mind. It was not to have His own way. The prophet David, in speaking of our Lord, beautifully expresses it, saying, "I delight to do Thy will, O my God; yea, Thy law is within my heart." (Psalm 40:8.) Again, in John 4:34, Jesus expresses the same, saying: "My meat is to do the will of Him that sent me, and to finish His work." This means, to keep my covenant. Again He refers to it (John 2:4), saying: "Mine hour is not yet come." What hour is referred to? In Matt. 30:26-28, He explains to His Apostles, telling them it shall be with you as it is with me. I came not to be ministered unto but to minister and to give my life a ransom for many. I must humble myself, keep my covenant. My mission is not to live, but to die; not to turn water to wine, not to raise the dead, not to feed the multitude, but to die; to keep my covenant, "give my life a ransom for many." Even so it shall be with you.

Again, in John 12:23-26, He explains the whole, as it refers to Himself and as it refers to us, saying: "The hour is come that the Son of Man should be glorified." How? Listen! By dying, by keeping His covenant. "Except a corn of wheat fall into the ground and die, it abideth alone; but if it die, it bringeth forth much fruit. He that loveth his life shall lose it, and he that hateth his life (sacrifices his life) in this world shall keep it unto life eternal."

Now, notice again how He includes us with Himself in this same sacrifice. (Verse 26.) "If any man serve me, let him follow me." Notice also that joint-heirship is promised to these, "and where I am there shall my servants be and . . . they will my Father honor."

Again, after His resurrection, when teaching His disciples, He speaks of the same things, and upbraids them for the lack of the very thing which made Him great. Hear Him (Luke 24:24-27): "O fools and slow of heart to believe all that the prophets have spoken. Ought not Christ to have suffered these things and to enter into His glory? And beginning at Moses and all the prophets He expounded unto them in all the Scriptures the things concerning Himself." He was censuring them for the lack of faith and consecration, for slowness to believe, and willingness to act upon their belief. He knew these Scriptures, these prophecies, and He believed them. He trusted in the Father. He laid down His life in fulfillment of them. He had acted upon His faith. He brought His conduct into conformity to His faith, and kept His covenant.

A sacrifice prompted by faith. This is greatness. They had enjoyed every proof possible and yet they were slow to take hold of them, slow to act upon them. We enjoy all the proof they had, and many things more, in the manner in which we are being fed on present truth, and in which its light is shining around us. Everything is fulfilled, or fulfilling right before our eyes, and yet some of us are slow to believe and slow to act upon our faith. Surely it is enough to awaken the dead to know what we know, and to see what we see. "Blessed are your eyes for they see, and your ears for they hear." (Matt. 13:16.)

## **A Great Character.**

Great faith is the basis of a great character. To exercise great faith in God and His blessed Word is true greatness. Hear our blessed Master saying, "Thy faith hath saved thee" (Luke 7:50); "Oh woman, great is thy faith (Matt. 15:23); "Thy faith hath made thee whole" (Matt. 9:22); "I have not found so great faith, no, not in Israel" (Matt. 8:10). And again, "The just shall live by faith." (Rom. 1:17). "All things are possible to those who believe"; and "According to your faith be it unto you," etc.

Now, what was Jesus' mission? 1st. To give his life a ransom for many; to redeem the world. (Matt. 20:28 and I Tim. 2:6). 2nd. To exemplify greatness from God's standpoint. (Phil. 2:5-8 and 1 Peter 2:21-24). 3rd. To show the Father's appreciation of it. (Phil. 2:9-11; Psalm 2:6-12; John 17:1; Rev. 5:13-14.) 4th. Thus to reveal the Father to us. (John 13:15-17; 17:23.)

The Father was going to ask a few of us to join with Jesus in this sacrifice, and also to receive joint-heirship with him as a reward. (Rom. 8:17.) Jesus had known the Father always, but we must be made acquainted with him. Jesus redeemed the world, and we on account of a similarity of faith in the Father, and in the Son, are permitted to be joint-heirs with Him, both in His sufferings and in the glory to follow. If it was safe for Jesus, who was rich, it is safe for us who are poor. "Behold I come quickly, hold fast that which thou hast, that no man take thy crown." (Rev. 3:10-11.)

## **True and False.**

In greatness as in other things, there is the true and the false. False greatness is oppressive, destructive. True greatness is constructive, upbuilding. Satan represents the first. It has its basis in disbelief, self-will, pride, ambition, vanity. It is great in the sense that a tornado or a cyclone is great -- doing great destruction. Under this head may be classed all the evil fruits of this destructive false kindness, false love, false humility, false strength. Its love, devotion and strength of character is manifested by making journeys, spending means and energy, making great show according to the flesh. Yet it all may signify that you are nursing an ambition, a pride, keeping alive one of those half-dead, half-frozen vipers by warming it up in your bosom. This means your sure destruction. This is all false, a sham. Get that thing out of there, brother. It is as unwise as if you would warm back to life a half frozen rattlesnake by putting it in your bosom. It is a sham.

You may claim that you are the master of these things at present. If so, this is why you should exercise your good sense and put them away forever. Bury them never to be brought to life again.

## **Illustration.**

It all reminds me very much of the showman and the boa-constrictor. The showman had reared it, and trained it; it quailed under his eye. He was its master. It would fold itself around his body and then unfold and fall off at his will, by only a motion of his hand. But it grew to enormous

proportions. There comes a time when he is no longer the master. He endeavors to go through the performance; the great snake coils around his body, and the crowd applauds; the snake tightens his hold, and the man reels, falls, and is dead. He has been killed by the thing over which he was once master.

This, dear friends, is all false greatness, and illustrates the unwisdom of nursing these adders of pride, ambition, envy and covetousness. They will soon prove to be our destruction.

True greatness we saw was constructive and upbuilding, and it is thus that our Lord illustrates it. It has its basis in faith and consecration. These are great in the sense of restoring perfect order, harmony and unity. This under present conditions is unnatural and difficult. These take hold of God and His promises as the chief good, and desire to follow His leadings at any sacrifice.

### **Satan Found Wanting.**

This faculty and disposition is wanting in Satan. He was one of the highest angels, yet lacked in the elements of true greatness. He did not take hold of God as the chief good; nor did he desire to follow His leadings, even without a sacrifice on his part. His mind, disposition and spirit was one of pride, ambition, envy and selfishness (Isa. 14:14). He had great wisdom, power and strength; yet is small from God's standpoint; and all will soon see that he is even unworthy to live (Heb. 2:14).

### **His Strength Admitted.**

"How will one enter into a strong man's house and spoil his goods, except he first bind the strong man" (Matt. 12:29 and Mark 3:27). Here our Lord admits that Satan is strong. But strength, wisdom and ability is not greatness. Alexander, Napoleon Bonaparte, Julius Caesar and others possessed all these to a degree, yet they were not truly great; they only added to the world's woes, they made no burden lighter, they have brought sunshine and gladness to no heart.

Power is not greatness; ability to mar God's beautiful works is not greatness. Greater is he who ruleth his own spirit than he that taketh a city.

### **Examples.**

God is great because God is love. "God so loved the world." This is the very consummation of all greatness. It turns midnight darkness to noonday brightness; it turns death to life, and destruction to redemption. Jesus is great. He proved it; He stood the test; and the most severe tests that have ever been applied to any mortal. "Consider him who endured such contradiction of sinners, lest ye be weary and faint in your minds" (Heb. 12:3). The prophet also testifies to this saying (Isa. 53:4-6), "He bore our griefs and carried our sorrows; yet we did esteem Him stricken, smitten of God and afflicted."

Look at His patient endurance and loving devotion, notwithstanding every human joy, hope and aspiration was utterly destroyed. Of the people there was none with Him; no companionship; He tread the wine-press alone.

Paul was great; he had great faith. The greater the faith, the lighter seems the afflictions. In 2 Corinthians 2:4 he records some of these things which he counts light, and which prove him great. (See 2 Corinthians 6:4-10; 11:24-29). And listen to what he says in 2 Corinthians 4:17-18: "For our light afflictions which are for a moment work out for us a far more exceeding and eternal weight of glory."

### **Great Ones of To-Day.**

I would like to mention some of our own number by name, who are having all manner of evil spoken against them falsely for righteousness sake, but I forbear lest it might offend some. But God knows I rejoice today to think there are some among us, who in a different manner perhaps, but truly, are on a par with some of these earlier brethren, not even excepting Brothers Paul and Peter.

### **Question to be Answered.**

Dear brother and sister, why should this consecrated life appeal to any of these with more force than to you or to myself?

### **Test Must Be Applied.**

Nothing is great that cannot stand pressure. A great organ is one which under great pressure pours out its sweet strains. A character is great just to the extent that it can stand great pressure and tests of temptation, yet with such unfaltering faith in God, and devotion to Him, and the naked principles of righteousness, that it never deviates from the path marked out in the blessed word. It, under great pressure, brings forth acts of patient endurance and loving devotion which under ordinary circumstances would never be dreamed of.

All fine tools, fire arms, machines, and all other things that are to be used in important places must be thoroughly tested. If they can stand the pressure they pass, otherwise they are cast aside as unfit. No wonder, when we properly consider the High Calling, that we should expect every test to be applied to us. But let us remember; it is our perfect faith being tested, not our imperfect works being judged. That the Father considers us worthy to be thus tested is of itself a high honor. He does not expect impossibilities of us; He does not apply the same tests to all, for some would not be able to stand what others could. The wise earthly teacher does not expect as much of the mediocre student as from the brighter one. That he expects much of a student is an honor, a compliment, to that student, and so when the Lord sends severe tests to our faith it is an honor, not a rebuke.

We now turn our attention in the remainder of this discourse to the instructions given by our Lord for the controlling and regulating of our conduct.

## **Instructions.**

He is teaching them and us, that in becoming His disciples (learners) our object must not be as formerly, or as is the balance of the world. (John 15:19). Secondly, that this new mind (which you now have in this earthen vessel) does not come up to the standard at first, but it must grow. Thirdly, remember who you are, follow my instructions, keep in line with my example, remember that all of your affairs have now become my affairs; everything shall now work good to you. This means that all these conflicts and self denials are intended to develop in you this new mind, the mind of Christ, with which you must seek to be filled. This means the development of patient endurance, long suffering, meekness, faith and love.

In the next place, instead of seeking to be great among men and having them acknowledge you as an equal or a superior, you pursue this "narrow way" and permit them to point you out and call you a fool. (Read 1 Corinthians 3:18-21; also Matt. 10:24-25.) Everyone shall be perfected as the Master. (Luke 6:40.) So, now, my instructions are: first, you must be converted (turned) from self-seeking, and place-seeking, and honor-seeking, and money-seeking, and become as this little child. I am using this child only as an illustration of docility, meekness, easy to be led, entreated and guided, and free from jealousy, envy, pride and ambition. I am not thinking of children, nor talking of children, but only using this child as an illustration. So don't get the idea that the Kingdom of Heaven will be composed principally of children, for there will not be one child in it, it will be composed of believers only. Don't think that you need to help prop up my character. My plan of redemption is so good that all the smart people of earth could not think of one little thing to add to it to make it any better than it is. My plan also includes all the children.

Secondly; you must humble yourself. Remember Satan, one of the highest angels, and mother Eve, a perfect creature, and Moses, the meekest man, all fell on account of pride and ambition; and let not this lesson be lost on you; we all have need to fear. "My soul be on thy guard." You don't know yourself; not one of us do. What is the effect truth should be having upon us? Knowledge puffeth up, love buildeth up. We are so injured by the fall into sin that we cannot stand prosperity or riches. What is the effect the truth should have upon us then? Why, as we grow in grace and knowledge and the magnitude of this work looms up before us and we see what it all means, the bringing up from the tomb and back to perfection of all the families of the earth. And as we see that all the power and wisdom is God's, the effect should be, as God intended, that we would become more humble and meek and child-like and sweet spirited; and we will thus become if we let the truth have the proper effect. Notice the ripe sheaves that are being gathered into the Garner; they are the sweetest child-like spirits I have ever seen. But if we find that we are becoming more and more irritable, nervous, discontented and dissatisfied, we have reason to fear. These symptoms are dangerous.

Thirdly; you must receive these little ones that believe in me as though it was myself, not seeking the great ones of earth, but keep close to these little ones. They are to be your companions. Don't set your opinion up as a standard for them, but keep your opinion out of sight. You keep close to these little ones who believe in me; trust me to keep them right, and you, too, if you keep with them. This means, if they assemble in convention you try and get there also, and eat.



Fourthly; you must not ensnare them. Do you ask How? By your own carelessness and lukewarmness and indifference to your own covenant; by your very want of meekness, childlikeness, humbleness and sweet spiritedness; by manifestations of self-will. Keep your covenant and thus by your example and precepts help them keep theirs.

Fifthly; you must not let the dearest things of this life ensnare you. What are these things? Houses, brethren, sisters, father, mother, wife, children or lands. (Matt. 19:29). The possessions and relationships of the flesh you must forsake. This does not carry the thought of injury or destruction, or of the forsaking of your duty toward your family or parents; but that in the future you no longer cherish fondly these earthly hopes and relationships. You turn from them to the Lord Himself who says, "In Me you shall have peace but in the world you shall have tribulation." (John 16:33.)

Sixthly; you must go still farther and sacrifice these dearest things. You have not sacrificed anything because you do not commit heinous sins, such as to get drunk, and to steal, etc.

The best time to sacrifice a husband or a wife is before you get married; to do so for Jesus' sake; to forego the right. You don't have to do so, you are simply invited to do so. Jesus did not have to sacrifice all these things either; He had a perfect right to get married and possess houses and lands.

In conclusion, dear friends, let us all seek to be great, not in our own way, but in God's way; not in this way or that way of which I may think, but in the ways of which no one but He could think. (Isa. 55:8-9.)

Dear Brethren, will your faith stand the test? We are now in the furnace to be proved as never before, and the worst has not yet come. "Hold fast that which thou hast."

May God bless you. Amen.

## **7 P.M. -- Praise Service.**

### **7:30 P.M. -- Discourse by Pilgrim Brother J. F. Rutherford.**

"Be Strong in the Lord." - Eph. 6:10-18.



The reading of this Scripture at once suggests the thought that we are weak, hence we are admonished to be strong.

There are different kinds of strength when we examine the subject from different view points. In the natural world strength is sought after diligently. The man who feels disease eating upon his flesh and bones seeks to check the malady and gain strength. Physical strength and power is desired and much admired by the world. The athlete enters the arena and is applauded because of his great physical strength and prowess. The man with a keen intellect is praised because of his power of perception. In money there is strength to a certain degree. The man

who can bring together the greater amount of capital, thereby combining vast enterprises, is hailed as the man of strength and power in the world. The increase of knowledge, engendering in the minds of men a greater sense of liberty has manifested its strength and power in the formation of labor and other organizations.

The Governments of earth are becoming more sensitive to the necessity for power, and so the nation which can produce the greatest amount of armament, offensive and defensive, is regarded by its subjects in awe and amazement because of the outward manifestations of its strength.

Ecclesiastical systems, imbibing the spirit of the world and feeling more and more the necessity for strength, have thrown out their lines in divers directions that they might have increased influence and greater power.

But, dear friends, this is purely a selfish strength. This is not the strength to which we would direct your attention. You have escaped this corruption which is in the world by giving up the desire therefore. It is our sincere desire this evening that we might, if possible, stir up your pure minds to the vital importance of acquiring now that strength and power that cometh only from the Lord.

The words of this text are addressed not to the world, but to the church; not to unbelievers, but to believers; not to sinners, but to those who have turned away from sin; not to those who are out of heart harmony with the Lord, but to those who are in the Lord, earnestly desiring to become members of the Christ body.

### **The Lord's Strength -- Our Weakness.**

The inspired Apostle says: "Be strong in the Lord and in the power of His might." Therefore we must conclude that all power is centered in the Lord, and so we find recorded in His Word that, "There is no power but of God." He it is whose glory covers the heavens and whose power rules the universe. The self-existing one, having neither the beginning of days nor ending of years. Truly of Him the Psalmist said, "From everlasting to everlasting thou art God." The heavens declare His glory, and the earth shows forth the works of His hands. The scope of His justice, wisdom, love and power is past the finding out of man. Of the immensity of His domains we have but the slightest conception. It is said, that the earth is a part of the solar system revolving around the sun, which system in turn revolves around the north star, and that system encircles the Pleades. Endless space, innumerable worlds! In the creation of all of these our adorable Lord and Master, Jesus, was the arm of Jehovah, and by Him were all things made and without Him was not anything made that was made. To Him hath been committed all power in heaven and in earth," and in Him we are invited to become strong.

Our weakness, therefore, must be very apparent to all who have made a covenant with the Lord by sacrifice, but to the world the real weakness of man is yet unknown. There was a time in the lives of most of us, no doubt, when we thought we were really strong; when we thought we were of some importance, and had some power and strength in the world. And when was that? That was when the God of the present evil world blinded our eyes so that we could not see and understand any of the wonders of God's power and the manifestations of His love; when the

grandeurs and beauties of His plan were entirely obscured from our mental vision. We were then wise in our own conceits, when we were, in fact, grossly ignorant and thought it folly to listen to the wisdom of the Lord. We gloried then in our physical strength and earthly wisdom. This weakness we inherited, dear friends, and therefore we will not chide ourselves because of it, but reference thereto serves to gently remind us of the necessity of acquiring strength from the true source of power.

Our first parent was, in a sense, strong. He was created in the image and likeness of Jehovah, and when God laid the foundations of his home "the morning stars sang together and all the sons of God shouted for joy." To him power and dominion over the earth were delegated, but by reason of his disobedience he lost these, together with his right to life.

The arm of the Lord was revealed unto us, in a measure, and we heard and believed His report. From His Word we learned that the disobedience of our earthly parent had brought sin into the world and death as the result thereof, and that by inheritance death had passed upon all men. Then we began to have some conception of our weakness and our insignificance in the sight of the Lord. We saw ourselves ruined in the fall and our existence but of a few days' duration. Then we cried unto the Lord in our distresses and He showed us more light, and by this light we ascertained that He had provided a means for our purchase and deliverance; that Jesus had voluntarily gone into death in our stead; that by the grace of the heavenly Father, Jesus had tasted death for every man; that he had been put to death for our transgressions, and raised again for our justification. We further learned that salvation was offered, through Jesus Christ, to all who by faith accepted and believed in the merit of His shed blood. Coming into this knowledge of the love manifested on behalf of the fallen race, we rejoiced to know that Jesus had become our purchaser; we believed on Him and fled to Him for refuge. Because of our faith and repentance by the grace of God we were reckoned perfect, therefore reckoned strong like unto our father, Adam, yet we were not in fact either perfect or strong; this perfection and strength being imputed to us only that we might become strong in the Lord.

Then to become strong in the Lord we must be in the Lord. Being out of Christ we only have a consciousness of our weakness with no means of becoming strong.

### **In the Lord.**

Then how do we get into the Lord? Only one way, and that by entering into a covenant relationship with God by sacrifice (Psa. 50:5; Rom. 12:10) Have we entered into that covenant? If so, then by it we agreed to sacrifice our reckoned human perfection and all opportunity to become actually perfect as human beings; and together with this, we agreed to give our time, our energy and what little strength we have in the service of the Lord. Having made this covenant by sacrifice, and having been accepted in the beloved, we are reckoned now as new creatures in Christ Jesus, yet not actually new, but begotten as new creatures to a new nature – new creatures in the embryotic state, which must be developed, must grow.

### **How Made Strong.**

Now we must grow strong in the Lord and in the power of His might, and to do that we must fulfill, to the best of our ability, our part of the covenant with the Lord. We must sacrifice and keep that sacrifice constantly upon the altar until it is consumed.

We know the Apostle speaks of babes in Christ. The one who has been recently accepted in the Beloved, who has been begotten to the divine nature, is a babe in Christ, but if we remain babes how can we be of service to the Lord? If we would obtain the prize we cannot remain babes, but we must receive a qualification for the service; we "must grow up to the measure of the full stature of the anointed one." We must be "made copies of the likeness of God's dear son."

### **Faith.**

One of the first essentials of strength in the new creature is faith. To be sure we must have a measure of faith before we are begotten as new creatures, but this faith must be increased; now our faith must embrace a wider scope.

Let us be careful, however, that we always distinguish between faith and credulity. To the babe in Christ Jesus this has special application, but it applies, more or less, to all. We know that credulity has been one of the hindrances to our friends who have remained in Babylon. Credulity is belief in some doctrine because some one in whom we repose confidence has told us it is true. Faith is the proof of sound doctrine by competent evidence, which evidence must come from a truthful source, and be clear, cogent and convincing. For instance, one says, "I believe in the doctrine of the trinity." Why? "Because my mother was a trinitarian, she taught me that it is a true doctrine and I know she was a good, true, Christian woman. It is indeed very proper for us to honor and respect our mothers, but we must also bear in mind that they likewise were made of clay, are of the fallen human nature, and subject to the same weaknesses all other persons possess. To accept as conclusive what they, or any other person might say concerning what God's plan is or ought to be, is mere credulity.

Another says, "I do not believe in the doctrine of the trinity." Why not? "Because God's Word clearly teaches to the contrary and His Word is truth, the only source of truth, and I have absolute confidence in His Word." Such is faith in the Lord's Word. Now, we can and must increase our faith in God's plan of salvation by proving all things by His Word, keeping in mind at all times the necessity of rightly dividing that word of truth.

From His Word we learn that, "Without faith it is impossible to please God." If we have faith in God's plan as revealed in His Word we will seek to bring ourselves into harmony therewith, and so doing, it necessarily follows, that in proportion as we bring ourselves into harmony with His plan, to that extent we will be pleasing to Him. So if we are in Christ, abiding there and His words are abiding in us, our faith will be increased and we will grow strong in the Lord.

## Knowledge.

Another means by which we may grow strong in the Lord is by obtaining a clearer knowledge of His plan. Closely allied to faith is knowledge, and to knowledge faith. They form a brace or support for each other, as it were. The inspired testimony is to the effect that, "Faith cometh by hearing (gaining knowledge) and hearing by the Word of God" (Rom. 10:17).

Then in order that we may have a knowledge of God's plan of salvation we must hear and understand His testimony. Living, as we now are, in the closing days of the Gospel Age such knowledge and understanding is of vital importance to our growth and strength, yea, to the very existence of the new creature in Christ. To us our Master now says, "Man shall not live by bread alone, but by every word that proceedeth from the mouth of God" (Matt. 4:4). Just as the earthly man lives by the bread that he daily eats and assimilates, just so the new creature must live by the spiritual food that he daily receives from the Father's storehouse. While such has been largely true during the entire Gospel Age, with stronger reasoning is it true now. A little knowledge concerning His plan places upon us the responsibility of getting more knowledge, not self wisdom, but that knowledge and wisdom that cometh only from above.

We must now be submissive to His will if we would grow strong in His might and power; therefore, we must learn what is His will and then use our best endeavors to do His will. To know His will we must daily feed upon His word and acquire a knowledge of the attributes of His character.

Neither can another do the eating for us. It is an individual process each must undergo if he would become strong. As we cannot sit at the table and observe others eat the food that is necessary for the natural body and hope thereby to grow strong, neither can we sit at the Lord's table and observe others partake of the spiritual food and thereby expect to grow strong in the Lord.

As the full grown man requires more food and stronger food than the babe, even so the Lord has provided the "strong meat for them that are of full age," and as we advance in time of development we must advance in ability to assimilate this strong food. Behold what a beautiful provision the Lord has made for our growth and strength in Him! We are in the midst of a great throng of enemies, Satan and his emissaries, all seeking to hinder us in acquiring strength from the Father's storehouse of food. None of these can partake of the bountiful provision the Lord has made for us. Truly we can say, "Thou preparest a table before me in the presence of mine enemies." Let us all, dear brethren, eat thereof and grow "strong in the Lord and in the power of His might."

The food with which this table is now laden, as we know, is the Lord's Word and the helps provided for a clearer and better understanding thereof. True, the Christians all through the age have had His Word, but during the greater portion of that time it was cooked and dished up in a nauseating manner. In the theological schools where the food for the household of faith was prepared and cooked many false doctrines were mixed with the pure food, thereby nullifying the good effects that otherwise would have resulted from dispensing the pure doctrine, and all who fed upon that mixed and adulterated provender became poor and lank and haggard. Our

extremity, therefore, became God's opportunity, and so He has caused a pure and unadulterated portion to be prepared and placed upon the table before us and He invites us to partake thereof and grow strong in Him.

Now, dear friends, we cannot grow strong by gazing at the food and remarking, "Oh, how appetizing; how inviting that food is, yet I am too tired to partake thereof today." You know there is such a thing as spiritual laziness, sometimes misnamed a "tired feeling." The old man greatly magnifies this disease.

We once knew a lady who spoke with pride concerning the great number of literary works she had in the library of her palatial home. She did not give much evidence, however, of having examined the contents of these books. On one occasion she said to her neighbor: "Oh, Mrs. Smith, you should just come in and see my beautiful new library! I have bought all red-covered books so they will match the paper on the wall." We cannot fold our hands and gaze upon the Scripture studies and other helps to our Bibles which we have placed upon our book shelves and thereby hope to gain strength. Neither can we grow by having some one else tell us what they contain. We must study for ourselves if we would acquire a knowledge of the Lord's plan and grow strong in Him.

While we are acquiring a knowledge of His Word we must also be developing the (spirit of a sound) mind. Our knowledge must be applied to a good purpose. Knowledge is not always applied to the acquisition of strength in the Lord.

Sometimes a man sits at a table laden with many good things to eat and partakes of the food unwisely. The result is indigestion and the man feels a great deal larger than he really is. He becomes very uncomfortable to himself and to those about him. And so we sometimes observe – we regret to say -- that some of the Lord's dear children sit at His table and partake of the food unwisely and the result is spiritual indigestion. They become swelled up, "puffed up" as the Apostle puts it, and therefore become very uncomfortable to themselves and to other members of the household who chance to be near them.

Those who sit at the head of the table, the teachers or leaders of the class, for instance, are exposed to these peculiar temptations and therefore deserve to be treated with great consideration and kindness, yet with firmness. To illustrate: One of these dear brothers who is thus afflicted with a bad case of spiritual indigestion, begins to feel a swelling in the head, which he attributes to spiritual growth, and so he soliloquizes with himself in this manner: "Here are a number depending on me for spiritual food, and I guess I know more than the other members of this class; certainly I do, otherwise I would not be occupying this position; the Lord has put me over them and I am their teacher; I will prepare the lessons from the Lord's Word in my own superior way; I will show them the right way, of course they will heed my voice, and thus I will teach them the deep things of God's plan." If the dear brother who is affected could stop long enough to take a mental photograph of himself he would discover that the old man is not yet dead, but is still seeking some honors; he would observe that it is the old goat who now attempts to dictate the course to be traveled. Now if he could just stand the old fellow up against the wall for a moment and say to him, "On what meat doth this our old goat feed that he hath grown so great?" the rebuke might so put him to shame that he would subside; but if this had not the desired effect,

then the new creature should use his prod and compel the goat to obey. You know you cannot lead a goat, but you must drive him in front of you where you can keep an eye on him. Failing to apply the needed remedy the dear brother finds self growing strong, "wise in his own conceit." A dangerous growth to acquire! He prepares a lesson, for instance, upon some original theory of what God's plan is or ought to be. This, with great weight and importance, he delivers to the class, and to his surprise, dismay and chagrin the other members of the class do not concur in his views. But, says he, I am the teacher, the leader of the class; they are going wrong and as their leader I must put them right; and so he conceives it to be his duty to force his views upon the class, because he is sure he is right. Failing to get the desired results he despairs of the Lord ever completing the good work once begun in these dear members of the household. He keenly feels that the harvest work is not progressing satisfactorily; that some serious mistake is being made. Ah, dear brethren, if we could always keep in mind that the Master of the harvest Himself is present superintending the work thereof, then we would readily come to the conclusion that no serious mistakes in the harvest are being made.

Let us keep in mind that if we would grow strong in the Lord we must partake wisely of the food furnished us and assimilate what we eat; appropriate it to the upbuilding of character like unto that of our dear Master

A fort is a strongly fortified place. It is always built for the purpose of resisting the attack of an enemy. So we are directed to build around us the fortress of the Lord that we may be strong in Him and thereby be enabled to resist the attacks of the adversary. If we are established in the faith and have grown in knowledge and the graces of the Lord, we have become fortified against error, false doctrines and strong delusions that are now upon the whole world. In our daily walks here we come in contact with the strong delusions and false doctrines, and if we are fortifying ourselves against these we are growing strong in the Lord. If I would grow strong, I must fully realize that "The Lord is my rock, and my fortress, and my deliverer; my God, my strength, in whom I will trust; my buckler and the horn (power) of my salvation" (Psa. 18:2).

Knowledge of the Lord's Word and full confidence therein develops in us that strength of character that enables us to encounter danger with courage and coolness, and unwaveringly receive the attacks of the adversary, knowing that our strength is of the Lord and in His power we shall conquer. The Lord has no pleasure in the unstable man, for he is like the waves of the sea, tossed about by every wind of false doctrine. Abiding faith and confidence in the Lord and His gracious promises begets in us fortitude, and by the development of these graces we are growing "strong in the Lord and in the power of His might."

### **Self-Control.**

We must keep ourselves well balanced, dear friends. We know that every well-regulated engine has a governor and a safety valve. Our spiritual engine must be provided with the appliances. Let us keep them in good repair; the governor, that we may control ourselves under all circumstances; the safety valve, that we may open it occasionally and let off the surplus esteem (self-esteem).

Every new creature in Christ must engage in a deadly warfare from the day he is begotten until the end of his earthly existence. The principal enemy with which we have to fight is self -- the old self-will. This we agreed to sacrifice and bring into full subjection to the Father's will; we agreed to become a living sacrifice. The old man does not like sacrifice. He objects, he pulls back, he kicks, he rebels, but he must be conquered, must be overcome. This conflict is so fierce between the old man and the new creature that the inspired witness of the Lord likens it to an attack upon a walled city, saying, that "Greater is he that ruleth in his own spirit than he that taketh a city." Instances might be multiplied of the daily conflicts we have with this enemy. Let us observe but a few:

True we have agreed to sacrifice our all in the service of the Lord, but says the old will, I don't care to have my body used in the service of the harvest work because it is degrading in the eyes of the world; I don't wish to be a gazing stock for the world and I will not be. This disposition must be overcome, and if we overcome it we are growing strong in the Lord.

We go about the city distributing tracts that perchance we may thereby be permitted to find some of the Lord's wheat. We know we are trying to do some good and naturally feel that the people would appreciate the effort, but instead we are met by some important personage who informs us that honest people have a better occupation than scattering circulars. In addition to this we are threatened with arrest because we are distributing bills (?) in the city without a license so to do, notwithstanding the fact that the laws of the land declare that no restrictions shall be placed upon the preaching of the gospel, and this is one way of preaching the gospel. The old man is disposed to say, well, the people deserve no consideration, they ought not to have the truth and I am wasting my time and energy in trying to give it to them, therefore I will quit the work, but the new mind must be in control now and learn that it is a great privilege to engage in the harvest work and receive the rebuffs from the world.

We go out to sell the Scripture studies. We take an order today for a set of books and go back the next day to deliver; we are met at the door with the announcement that the lady of the house does not want the books, that her minister has told her they are infidel books, and when in the spirit of kindness we call attention to the fact that she gave her order for the books and certainly does not wish to repudiate her word, in answer thereto we are, in a rude, angry and threatening manner, thrust out of the house. At once the old man suggests that we resist the evil in strong terms, but no, says the new mind, here is an opportunity for self-control.

Then we go about the world otherwise trying to do good to all as we have opportunity, and because of our efforts men speak evil of us and denounce us as hypocrites, infidels and deserters and say all manner of evil against us falsely, and if for the love of Christ we control self and rejoice in the tribulation, then we are growing strong in the Lord. All these experiences help us to grow strong if we are rightly exercised thereby.

And while we are developing the spirit of self-control, if we are gaining the mastery over self, we are at the same time developing patience. We are learning to be patient with the weaknesses of others, remembering that they are of the fallen race; we patiently and joyfully endure such trials and tribulations as may be our good fortune to have, and by doing so we are daily growing stronger in the Lord.



## Piety

Another means of acquiring strength is by cultivating that element of character known as piety or Godlikeness. The greater knowledge we have of God's character and the more we strive to bring ourselves into harmony therewith, the more God-like we become. We cannot grow in the Lord as long as we permit evil thoughts to abide in us. An evil thought is the father of an evil deed, and these continued in lead to weakness and ultimately to destruction. If we would grow strong we have no time to occupy our minds with idle and harmful gossip. We should keep in mind that our time belongs to the Lord, and if we would become more like Him we must have our minds occupied with His business, and not with evil surmising concerning other people's business. If we have reached the point in the development of Christian character that we will not permit ourselves to surmise evil concerning others; that we will not permit our minds to be occupied with unholy thoughts, but on the contrary delight to meditate day and night upon God's gracious plan and love, and our desire is to walk as Jesus walked and talk as He talked, then we are gathering strength from the Lord that will enable us to stand the fiery trials when they come upon us.

## Love.

One of the certain evidences that we are growing strong in the Lord is the development of the spirit of love. The Apostle says to us, "God is love, and he that dwelleth in love dwelleth in God and God in him" (1 John 4:16). What better evidence of strength could we have than the fact that we are dwelling in God and He in us? If we would dwell in Him we must develop love. Love is the counterpart of selfishness. He who harbors in his breast the spirit of selfishness cannot hope to grow strong in the Lord. When we consecrated to the Lord we agreed to put self to death, to sacrifice self in His service. If we would grow strong in the Lord we must carry out that agreement. In proportion as we permit self-ease and comfort and self-interest to stand in the way of our service to the Lord, in that proportion we refuse to fulfill our contract made with the Lord. Our service to be acceptable must be prompted wholly by a loving devotion to the Lord and His cause, and not by the spirit of selfishness, vainglory or pride. Let us remember that "God resisteth the proud, but showeth His favor to the humble"; therefore, if we would grow strong in the Lord, if we would abide in Him and have Him abide in us, self-pride and vainglory must be cut off and pure and undefiled love enthroned in our hearts instead. Our love for God must be supreme and we must joyfully serve Him even though that service cost us much suffering and pain. our love for the brethren must be pure, noble, unselfish, with a burning desire to follow the example of our Master in laying down our lives to serve them. Our sympathetic love for the fallen human race must be such that we can look upon those who despitefully use us and persecute us for righteousness, who revile us because of our loyalty to the Lord, and mentally, at least, say to ourselves, "I am glad that the Lord has permitted me to die for you." When we reach the point in the narrow way that we can entirely eliminate self, when loving and loyal service to the King is our only and sincere desire, then we may feel that we are growing strong in the Lord and in the power of His might. When we are weakest in self, then are we strongest in the Lord. His strength is made manifest in our weakness.

## Prayer.

Fully developed strength in the Lord is not the result of the efforts of a day, a week or a year, but is the sequel to a faithful fight even unto death; neither is it then acquired by our own efforts. True, we must put forth all the effort we can to acquire that strength; but we thank God that He is not judging us by what we actually accomplish, but by our heart's sincere desire to serve Him and become like His dear Son. He has provided many avenues through which we may manifest this desire, chief amongst which is the avenue of prayer. What a wonderful privilege we enjoy in prayer! What a source of strength it is! The Captain of our salvation, He through whom we receive all our strength, now says to us, "As the Father hath loved me so have I loved you, continue ye in my love. If ye abide in me and my words abide in you, ye shall ask what ye will and it shall be done unto you" (John 15:9, 7). Ah, dear brethren, here is a certain means of obtaining strength. Jesus loves us, and of this we are quite sure. He was touched with the feeling of our infirmities, He knows our weaknesses and shortcomings. If we abide in Him and His words abide in us, we may go to the Father through Him and obtain the strength necessary to help us to overcome. If our faith is weak, we can come to the throne of grace and have our faith increased; if we lack knowledge and understanding of God's Word, and are doing our best to acquire that knowledge, we can come to the Lord and receive the needed help. If because of weakness we are unable to control self; if we have a sincere desire to cultivate patience; if we are lacking in love and devotion to the Lord and His people; if we need more of the holy spirit, we may in the name of Jesus Christ ask for and receive what we need. If some opportunity for service is presented and we are in doubt about the manner in which we shall proceed, we can come to the Lord and be assured that He will supply us liberally with the needed wisdom. The inspired witness of the Lord, who had similar experiences, no doubt, to ours, says to us: "Let us come confidently unto the throne of grace that we may obtain mercy and find grace and help in time of need" (Heb. 4:16).

Prayer is closely related to every means opened to us for the development of strength in the Lord, and he who neglects to come often to the throne of grace for help in time of need is not only in danger of losing what little strength he has acquired, but in danger of losing the very spirit of Son-ship.

## Service.

As the arm of the blacksmith grows strong with constant use, so the new creature obtains strength by activity in loyal service to the Lord. Especially is this true at this time. We are nearing the close of the harvest and there is now no time for idlers. If we would do anything therein we must do it quickly. If an opportunity for service is presented let us seize it and put forth our best efforts to serve in harmony with the plan of the Lord. We may have faith and knowledge and a desire for service, but if we stand idly by and fail or refuse to take hold and serve when the opportunity is ripe, we may be sure we will not be able to long retain what we have, but that which we have will be taken away and given to him who hath and who will make use thereof.

How many of the Lord's children can testify of the strength received from actual service? We dare say that every one here who has made progress in character building can testify to strength

obtained while serving the household in some capacity. The Lord gives us different opportunities for service. We cannot all serve in the same place. He is placing the members in the body where He wants them. If our part is to saw wood and carry water, let us do it gladly; if it is to hold up the hands of others who serve let us rejoice that we can do so. All who have the faith, knowledge, love, desire and zeal for service will be given some opportunity. The opportunity may seem small, but it is the small things that lead to larger ones. Let us despise not small things. We may serve some brother by a kind look, a sweet smile, a word of encouragement, a kind and loving act, or the breathing of a silent prayer for a brother whom we see in need of help – and we all need help. One instance may serve to illustrate this point. We knew a brother in the truth whose privilege it was to give a public discourse before an audience of strangers. But only one other brother in the truth was present. At the conclusion of the discourse several in the audience, without invitation, began to ask many questions which would tend to confuse the beginner, but by the help of the Lord the speaker was enabled to answer all the questions by reading from the Lord's Word. On leaving the place of meeting the brother who had sat silently through the service, remarked to the one who had served as the speaker: "Brother, when those questions began to come so thick and fast I felt for you and I was praying for you every minute." That service without a doubt, though done in secret, bore its fruit.

### **Assembling Together.**

We are admonished by the Apostle to forget not the assembling of ourselves together, and especially as we see the day drawing nigh. Why? Because this is a means of service and leads to strength in the Lord. In a short time the harvest work will close, therefore the necessity is great that we get the sealing in our foreheads and hearts now that we may have the strength to stand in the evil day. We can serve the Lord and His children by coming often together and talking with each other concerning His plan and His love for us.

Why is this great convention assembled here for a whole week? That we may have a season of fellowship and build each other up in the most holy faith. The fellowship of kindred minds greatly aids us in growing strong in the Lord. We tell each other what the Lord is doing for us; we talk with each other face to face and see the power of the gospel working in each other to know and to do His good pleasure. We are all one body in Christ, one family, having similar hopes, similar desires, like sorrows and like joys; we grasp each other by the hand and speak a cheering word and our souls are thrilled by every heart throb, and so with new courage we renew our consecration vows; with a new determination to overcome we go forward in the battle, fighting the good fight of faith even unto the end. We go away from here with renewed hopes and new joys, rejoicing because we are growing "strong in the Lord and in the power of His might."

### **Necessity for Strength.**

Is it necessary for us to now acquire this strength in the Lord, and if so for what purpose? Manifestly it is very necessary, otherwise the inspired witness of the Lord would not have told us so. The Apostle says to us: "For even hereunto were ye called, because Christ also suffered for us, leaving us an example that we should follow in his steps" (1 Pet. 2:21.)

It was necessary for our dear Lord to suffer. "He was made perfect through sufferings." His suffering was an example to us, who are called to be made members of His body, so we must likewise expect to suffer. It takes strength to suffer, dear friends. This strength comes to us only from the Lord and then only when we are faithfully and lovingly devoting our lives to His cause.

It was necessary for our Head to go through the fiery time of persecution. The body members must follow the head. If we rush through a flame of fire, the body gets through to safety only by following the head. The head never follows the body. The old man rebels against going through the fire. It requires strength to make him go through, which strength we get only from the Lord.

Again, Jesus says to us, "If any man will come after Me, let him take up his cross daily and follow Me." Strength is required to take up and bear the cross daily. Are we doing what we can to get that strength?

Our Master was despised and rejected of men, persecuted and denounced as a blasphemer. The followers in His footsteps may expect to have similar experiences, because the servant is not greater than his Lord. No doubt the severe testing of the feet members is yet future -- the very near future. It will require strength from the Lord to stand the test. He has provided, in advance, the means for us to acquire that strength and if we do not do so it will not be His fault.

Oh, dear brethren, does it not require strength now to live close to the Lord, where we belong, surrounded, as we are, by a great horde of enemies; and in addition to these, our former friends, neighbors, yea, even the very members of our families, telling us we are wrong and treating us as though we were demented. It takes some strength to overcome the besetments of the world. It requires strength to break down pride and ambition that once goaded us on to obtain the honor and plaudits of men; it takes strength to keep the old man under; it takes strength to resist the many machinations of the adversary; have you that strength, dear friends?

But, dear brethren, if strength is now required when conditions for service are favorable, what greater strength will be required to stand when the conditions change and the final test is applied! Will we be able to stand? No, not alone, but Yes, if we are "strong in the Lord and in the power of His might."

The evil day is now upon us. In a short time the conditions will change. By the eye of faith we look into the Lord's sure word of prophecy and, in the light of this, we view conditions about us and can clearly see the elements rapidly gathering that will bring upon the feet members of the church the fiery trials that are to try and test them. The Lord's inspired witness has told us in advance to "Think it not strange concerning the fiery trial which is to try you as though some strange thing had happened unto you," but rather expect it and be prepared for it (1 Pet. 4:12.) It will be too late to heed this message and prepare when the trial is upon us. Are we taking advantage of the favorable opportunity to make the preparation?

To us the message now comes: "Put on the whole armor of God." An armor is put on that the wearer may be able to withstand the attacks of the enemy. It is not needed where there is no danger. Then why put it on now? "That we may be able to stand against the crafty ways of the adversary in the evil day." His ways of deception are numerous and to his aid he calls a multitude

of assistants. We are told that if possible he would deceive the "very elect." Such will not be deceived because the Lord will have the requisite number to fill up the body, but the question is, who will be able to stand that they may be made a part of the body? The Word answers, "They who have put on the whole armor of God," who are "strong in the Lord and in the power of His might."

The Scriptures disclose that the age will end with a time of trouble such as never was since there was a nation. They also bear out the thought that the final testing of the church will be one of severity, a fiery test. The members now being developed have more light than has heretofore been revealed, and it would be reasonable to conclude that the test of these would be more crucial than of those who have less light.

We are assured by His Word that "the night cometh when no man can work." The present period of tranquility is evidently permitted by the Lord for one special purpose, namely, that the harvest work may be completed in due time. "The four winds of the earth," symbolic of the great time of trouble which must shortly come upon the world, are being held back for the present. For what purpose? "Until the servants of our God are sealed in their foreheads" (Rev. 7:1-4). It necessarily follows that as soon as the sealing process is finished the winds of persecution will be loosed and the fiery time of trial and testing will be upon all who have been sealed.

The sober, thoughtful student of the Lord's Word can now clearly discern the gathering of the elements that will bring about the fiery trial upon the church. The Governments of earth are fortifying in every manner conceivable to their heads; they are gathering strength from every possible quarter. The powers of these are being centralized. The strong arm of wealth is crystallizing into mighty compacts. The various churchianity systems -- the mother and her numerous progeny -- are taking steps to bind themselves together with the ties of affinity. That all three of these great elements of Babylon will in a short time be tacitly, at least, united and bound in one mighty bundle, the word of prophecy clearly points out. Such an unholy alliance could result in nothing short of persecution of all who stand for truth and righteousness. The evil disposition of man is to-day what it has been since the fall -- even more so. The hand of the civil power has never refrained from the persecution of the Lord's true followers when forced by the influence of the ecclesiastical system. There will be no departure from the fixed rule.

But in what manner do these coming events affect the Lord's children to-day? In this, dear friends, that we are permitted to see in advance the approaching time of testing and trials that we may prepare for its coming; that we may be able to get on the whole armor of the Lord and be able to stand it. Negligence on our part at this time should be the height of folly. Rather let us be "diligent to make our calling and election sure." You ask how? The Lord's Word answers: "Take unto you the whole armor of God that ye may be able to withstand in the evil day, and having done all, stand. Stand, therefore, having your loins girt about with the truth, and having on the breast plate of righteousness" -- a righteous character guaranteed to us by the precious blood of Jesus and developed in us through a faithful service to the Lord --; "and your feet shod with the preparation of the gospel of peace; above all take the shield of faith, wherewith ye shall be able to quench the fiery darts of the wicked." Ah, dear friends, with the shield properly adjusted and securely fastened, the fiery darts of the adversary will not even jar the armor, but will fall harmlessly at our feet. "And take the helmet of salvation" (but be careful that your head is not

too large for it) and the sword of the spirit, which is the Word of God." His Word is sharper than any two edged sword and upon this sword the enemy must fall in the final conflict. Then when we get on this armor we are to stand, "praying always with all prayer and supplication in the spirit and watching thereunto with perseverance and supplication for all saints." Thank God for such an armor; praise His name for such a wall of strength. Brother, have you the armor on? If not, be quick, get it on, for the time is short. If you have the armor on, go quickly and help some weaker brother get it on. He is struggling to get it on and he is your brother, help him. Then when both of you have the armor on and securely fastened, stand! Do not turn your back on the enemy and flee, but right about face, present your sword and silently await the attack. "In quietness and confidence shall be your strength," in the Lord.

Shall we be alarmed at the approach of the enemy? Shall we shrink from the crucial test? No, dear brethren; if we have on the whole armor of God, buckled on tightly and securely, we are now "strong in the Lord and in the power of his might," and we will be able to come off more than conquerors. If he is for us who shall be against us, to prevail against us? "Because thou hast made the Lord thy refuge, even the most high God thy habitation, there shall no evil befall thee." (Psa. 91:9, 10.)

We will need strength to stand that final test, and courage too. We have the opportunity to get both now. If we have the courage that is born of faith and strengthened by loving devotion to the service of the King, we can stand in the deepest darkness of the night and enjoy bright day, and when the wildest storms are lashing the waves and dashing them against the mountains, we can in "quietness and in confidence" stand with our hand in that of the Master and truly say: "The Lord is my light and my salvation; whom shall I fear? The Lord is the strength of my life; of whom shall I be afraid. (Psa. 27:1.)

The harvest is almost ended, dear brother; the Master is present directing the closing days thereof. Still the darkness covers the earth and gross darkness the people, but to His faithful followers the glad message comes now saying, "Arise, shine, for thy light is come." By the aid of this light may His dear children now grow "strong in the Lord and in the power of His might," and may He help us all to get the armor on and securely fastened and to stand. Amen.

## **Overflow Meeting Sunday Evening.**

*On Account of the large attendance, it was found necessary to have another overflow meeting, so while Brother Rutherford spoke in the auditorium of the Natural Food Building, the overflow meeting was held in the reception room on the first floor and was addressed by Brother H. C. Rockwell, of New York City.*

*As there were not many chairs, the friends were invited to sit on the floor, and many took advantage of the generous invitation and sat at his feet while he spoke in substance as follows:*

Dear Friends: Our theme will be "The Lord's Family." I trust that all who are assembled here tonight have the feeling that they are meeting together with the members of the Lord's family, all

members of the Heavenly Father's Family.

As I was coming to the convention from New York City, I noticed in Buffalo a number of large signs announcing there would be a week of special jollification, called "Old Home Week." The thought came to my mind that if worldly people could get together and have a grand time with acquaintances and neighbors, going over old times and considering the conditions and welfare of one another, how very appropriate it is for the Lord's people to get together and talk about our home and spiritual interests. I trust we have all taken the position of having left the old Adamic home upon the earthly side and have started on the journey for the new home. We are celebrating a "New Home Week." Some of us have been on the journey for some years and some for a very limited time, but I trust we have continued to make progress on the narrow way and that our hearts are rejoicing continually. We are all members of the Heavenly Father's Family. It is a high and wonderful privilege to have been adopted into the Heavenly Father's Family. It is the oldest family in the world and one that we glory in. Our Heavenly Father has always existed, and our Lord was the first created.

As we come down the ages, we find where noble members of our family have existed, and, as we understand from the Scriptures, have entered into the joys of our Elder Brother and are with the Father.

I trust these convention meetings will be very helpful to us, causing us to consider the welfare of the other members. A great deal of love should be manifested. In the earthly family each looks out for the interests of the others, and if any are weak or crippled in any way, how the loving brothers and sisters look out for the interests of those so afflicted. So with us, some are lame and very weak, requiring special attention, and that is one of the reasons for our coming together – to strengthen and encourage one another, to build one another up in the most holy faith, that we may continue on in our journey which will end in our Heavenly Father's home.

When thinking of our Father's house, we think of our Elder Brother, the Lord Jesus. Nineteen centuries ago He told His followers something about that heavenly home and that he was going away to prepare something for the other members. We understand that our Lord has for past long centuries been engaged in preparing a place for His Bride, that the members might enter into the joys given Him of glory, honor and immortality.

I look upon this convention as a family reunion. I remember seeing something in the papers not long ago of a reunion of the Smith family and the Smiths from far and near came to have a jubilee. Here is a grand family reunion, and what a wonderful reunion this is; not of the Smith family, but of the Lord's family from various parts of the United States and Canada. This is a glorious foretaste of that family reunion that will be when all are gathered together beyond the "Vail." The Smith family had a grand feast and many wonderful things to talk about; so there will be in that great family reunion. Think of the songs that will go up from them all. Think of meeting our Savior as our Elder Brother, and think of looking into the face of our Heavenly Father, whom no mortal man has seen, neither can see! Think of meeting Paul and Peter and John and all the other faithful brethren! Think of what a grand banquet will occur -- the marriage supper of the lamb, and think of it enduring for a thousand years! Think of the song of Moses and the Lamb as it will then be sung! It is a time to look forward to.

And now dear friends, as brothers and sisters in the Lord, as members of this family of God, it is our blessed privilege to have this glorious prospect placed before us, and when the whole family has passed beyond the "Vail," what will it mean? Will it mean that the members will be engaged in pleasure on their own behalf? No. One of the chief pleasures will be that they will have the privilege of dispensing the Heavenly Father's blessings to all the families of the earth, so that by the end of that thousand years, all the families of the whole groaning creation will be adopted into God's family, that is, all the willing and obedient; just as at the present time, those that have the ears to hear and the eyes to see the things that the Father has to bestow, who will accept the conditions that He lays down. So we understand that in a somewhat similar manner, those that will accept, during the Millennial Age, the conditions that are laid down, enter into the membership of the Lord's family.

As in the earthly family there are different degrees of relationship, such as the inner circle, consisting of the brothers and sisters, then the brothers-in-law, etc., and various other degrees. So I would understand in the divine family, the spiritual members, the divine, highly exalted ones will be the inner circle. Then comes the great multitude, and we might say they come next in relationship to the Lord. These would include not only the great company but also the angels. Then come the ancient worthies, those who by their faith and obedience attained unto a better resurrection. Then outside of those will come the world of mankind; they will be on the human plane, and they will be the sons of God in the same sense that Adam was a son of God. During the thousand years reign of our dear Redeemer and His Bride, they will represent the Father, but at the end of the thousand years, we read that the Lord will deliver up the Kingdom to the Father that God may be all in all; then the divine family will be completed and throughout the ages of eternity, there will be universal joy, peace and happiness. As we understand the Father's purpose, there will be nothing to cause sorrow or suffering, but all things shall be made new. Every knee shall bow and every tongue shall praise our God from whom all blessings flow.

Now then, dear friends, the journey which we are called upon to make is a narrow, difficult way, leading to our Heavenly Father's home. Comparatively few during this Gospel Age appreciate the privileges and relationship that are yours and mine to enjoy.

When I think that we can by faith look up into the Heavenly Father's face and appreciate the fact that we are His children, begotten of His Holy Spirit, and that all the experiences of life are designed to work out our eternal welfare; when I think of all the mighty power and wisdom that the Father has exerted in our behalf, and that nothing can injure or harm us, it makes me very thankful. It seems to me, dear friends, that among those that have knowledge of Present Truth, there are some who fail to appreciate the glorious privilege and relationship that our Lord's people have been invited to attain to. Some think the Father is a long way off and that it takes a long time to reach Him. Some also have the thought that we cannot approach without a mediator. I trust that the most of us have come to appreciate the fact that we can enjoy the same relationship to God as our Father that our Lord enjoyed after His consecration and baptism. We do not need any mediator or go-between; because we are entirely at-one with the Father – we are His children. Suppose an earthly parent should arrange for his children to go to an outside person before the child could come to him. It would be an unreasonable proposition. So it is with the relationship we enjoy with our heavenly Father. We are invited to come boldly to the throne of



grace in every time of need, receiving grace and strength to help and sustain us.

Our dear Redeemer had something to say about the mansions in our Father's house. He said there were many mansions but that He went to prepare a place for us. We have some conception of these as we look into the Scriptures, but we have a very limited conception of what our Redeemer went to prepare. We have some conception of the angelic plane upon which the angels exist. The Scriptures have quite a little to say about the power, ability and glory of the angels. It is intimated in the Scriptures that they are a little above men. We have some conception of what a perfect man would be like, but not a full conception, because the race has degenerated during the past six thousand years. All are now very imperfect. Now then, our heavenly Lord, having all power and authority in heaven, has been engaged in preparing a place for those what will be associated with Him. If an earthly man with millions of dollars at his command and all the time he wanted could arrange a beautiful mansion with beautiful grounds around, etc., how much more can our heavenly Lord, with all power and 19 centuries at his command, prepare a glorious place for His Bride. That is the home toward which we are journeying, and I trust it will be your privilege and mine to enter into that home, that we may enjoy it throughout all eternity and that we may look into the face of our Heavenly Father, and all through eternity be expressing praise to our God.

Now while we have this glorious hope before us, we also have present with us the stern reality that while not of the world, we are still in it. Let the desire of our hearts be to promote the interests of the other members of our family, so that in dealing with the other members of the family, we will remember that the Heavenly Father loves them and esteems them as His children, and as such, we have a great deal of responsibility toward them, as fellow members of the divine family. We should be very careful of the welfare of the members of Present Truth, adopted into the heavenly family. Sometimes the members of the earthly family try one another severely because of certain traits of character differing from the other members of the family. And so, we find it is with the Lord's family. He is not selecting the noblest and best of the race to constitute His family, but the opposite. He called the weak, the poor, and the despised according to the flesh and not many mighty, wise or noble. But the Lord sees that this is the best arrangement, and these are rich in faith. Thus we can see that because of inherent weaknesses and imperfections there may be trials among the members of the Lord's family before all are perfected. So, it will be necessary for us to exercise patience, we will need to be kind and considerate, and we should look upon the other members of the Body as does the Heavenly Father. He does not look upon the flesh, but upon the heart, the new mind. And dear friends, I sometimes think our greatest trials come from those with whom we are associated in Present Truth. We look upon the world as absolutely helpless in the hands of the god of this world -- Satan. It is foolish for any natural man, in his own strength and ability to think that he can resist the influences of evil that surround him on every hand. As an illustration of this we sometimes read about men who have been placed in positions of trust, who for years have been faithful, but suddenly they fall away, they become dishonest. But, with the Church our Heavenly Father has arranged that His grace is sufficient, and that through His strength, we can overcome the evil influences of this present time. The world is completely helpless in the hands of the adversary, and all are possessed with the spirit of an unsound mind. It is only those that have the spirit of a sound mind that can overcome. We look upon the world as being in an insane condition, and they are in a position where they cannot appreciate completely the things that are right or

reasonable. So if some of them tried to do us injury we should not try to retaliate, but should look upon them with pity. But when we look upon the members of the Father's family, we should expect them to be filled with the spirit of love and fellowship at all times. Let us try to think that they are, and if they do those things that are contrary to the spirit, let us remember that it is part of the old man, part of the flesh. Then again, let us remember that if we have the disposition to retaliate, we may rest assured that the adversary will keep us busy. Our time is to be devoted to doing the Lord's will, we are not to go about seeking to set ourselves right. For my part, I would rather leave that to the Lord. When we have given all things, we have given our life, our all, which includes our good name, our reputation, all that we have. Therefore, knowing that He loves us, He will look out for our interest and our welfare; we need not be specially concerned about being set right with others. When we are experiencing hard knocks from others we may look upon these as blessings in disguise. I remember a picture representing a strength testing machine with a gauge standing up for 12 or 15 feet. There is a little block of wood at the bottom of the machine and to this little block is attached the image of a little man. The strength test consisted in that a large mallet is used to strike a peg and send the block of wood up. The higher it goes, the greater strength is tested. The man with the mallet was trying to send the wooden man high up in the air. Over the machine was written, "Every knock is a boost." It means that if we are rightly exercised by our trials, every knock will be a boost in character building, and in the Lord's favor which is correct from a Scriptural standpoint. The harder the knock the higher the boost! Blessed are ye when men shall say all manner of evil against you falsely etc. Matt. 5:11, 12. So we see the principle of this, as we experience these hard knocks and the little taps, if we are rightly exercised by them, it means that we are developing and that we will be found worthy to enter into that glorious home that is reserved for the people of God.

I sometimes think of the development of Christian character in the nature of putting up a building. In the city of New York, they are engaged in erecting that class of buildings known as skyscrapers -- so tall that they seem to scrape against the sky, forty and fifty stories high. First of all, there is the cost to be considered. So with us, we are exhorted to count the cost, etc. We found what the cost was, we were to give our all, all our time, energy, talents, etc. Then after considering the cost I might say the work began. We must be properly fastened to the foundation. In putting up these big buildings, it may be necessary to devote weeks and months in removing the dirt and debris, until they strike the solid rock. So when we consider the various opinions, theories and doctrines of our day such as the evolution ideas and higher criticisms we find there is a great deal of rubbish and debris to get rid of before we get down to the true foundation, the solid rock Christ Jesus, a ransom for all. Then it is necessary to build upon the foundation. I like to think of our building as having seven stories, seven being the symbol of completeness. It is true there are eight things mentioned by the Apostle -- 2 Peter 1:5-7. We are to add to our faith fortitude, to fortitude knowledge, to knowledge self-control, to self-control patience, to patience piety, to piety brotherly kindness and to brotherly kindness love. I like to think of faith as the steel frame and cross beams that run throughout the building, and that the other seven attributes are the seven stories that are attached to the steel super-structure, and the height of the building will depend upon the height of the stories. Some may have a little virtue or fortitude, but a great deal of patience. They might have seven feet of one and forty of the other, so to speak. Suppose they were each alike, say 40 feet each, what a tall building we would have; but, on the contrary, if we had only a few feet of each, we would have only a small building.

Again the building material is not of wood, hay and stubble -- traditional errors -- which are used by so many Christian people of this present time, but it is the gold, silver and precious stones the divine truths of the Word of the Lord. What a glorious sight it will be from the divine standpoint, when these character structures that are being developed at the present time will be completed. Again many of these buildings are fire proof. The thought is that there are 144,000 Christians, members of the divine family who are engaged in developing the skyscrapers of Christian character structures. Think of it when 144,000 of these structures are gathered together. In Revelation these are described as the New Jerusalem, the glorious city, etc. This glorious city is to come down from God, to be established upon this earth, and the blessings are to flow out to all the families of the earth represented by the rivers of the water of life Rev. 22:1, 2.

We understand from the Scriptures that the closing days of the last members of the body of Christ, the members of the Lord's family upon this earth, are to be of special trial, and the Scriptures say, "Who shall be able to stand?" It is those who have put up these high character structures. You will notice that the gold, silver, etc, are fire-proof materials. A great fire and earthquake are coming, and only those buildings which are fire-proof and which have been erected according to the specifications outlined in our heavenly Father's Word, is there any hope of their standing.

With this thought in mind, let us put forth renewed effort to erect a building that will be found worthy to have a place in that City, the New Jerusalem.

Dear friends, may we be permitted to enter into that last family reunion, with our Redeemer and Heavenly Father. May it be yours and my great privilege to be associated together with our Lord, to sing the songs of praise and thanksgiving in that time.

**MONDAY MORNING, SEPTEMBER 2.**  
**9:30 A.M. -- Praise and Testimony Meeting**  
**led by Brother Hirsch of the Bible House.**

Brother Botham: The first thought I had this morning when I awoke was, How short the time will be when we will have to break up this convention and go our several ways, some to the homes and some to the different cities, and I shall miss the grasp of the hand the sweet fellowship I have enjoyed in these seven days. And this assurance came to me: that I would not have to miss the fellowship of my beloved Lord and that I have His words with me constantly. I have a cousin who had a beautiful diamond, and he used to hold it before the light and watch the light being reflected from its different facets. This jewel came to my mind this morning: "Our light afflictions work out for us a far more exceeding and eternal weight of glory." I thought, now that is a diamond. Then I turned it around and looked at it. Did you ever read that verse backward and see how beautiful it is? If you have not done so, you have missed its full beauty and significance. Take the word "Glory." No one has ever yet been able to describe or define that word. And then, "A weight of glory." And then, as if that were not enough, he adds, "A far more exceeding and eternal weight of glory." God grant that this diamond may shine into the hearts of each one of you and comfort you on the way, as it has comforted me.

A Brother: I believe the social amenities of the convention will aid me in putting a finishing polish, a smoother finish, on my Christian character.

Sister Berger: I have the privilege of bringing greetings, sympathy and love of our church in St. Louis, and I wish to witness for the love of our Heavenly Father and our Lord Jesus Christ, and tell you how the truth came to me two years ago. On Easter morning I went to high mass, and I found the tract, "The hope of immortality" before my door. My husband being with me, I put it in my prayer book; but I read the tract, and high mass was out before I knew it, for I was studying over the tract, and could not understand what immortality meant. So I took it home and sent for the six volumes, and read the six volumes in six weeks. The first volume I read four times. While I was reading the first volume, the priest came to our house for a collection. I was at about the fourth chapter where it treats of the Narrow Way and the Broad Way. That Scripture is more to a Catholic than any other Scripture, and I told the priest that no wonder we pray, "I thank Thee, God in heaven, that we have been born of Catholic parents." I told him I used to be sorry that I was born a Catholic, but that now I was glad of it, that now I knew why the Catholics were on the narrow way. But after a while when I read the book the second time and began to understand about the Pope I said, How sorry I am that I told the priest what I did. I sent a letter to the Bible House and told them that I was a Catholic and would they please send me some more literature explaining about antichrist and popery, and they sent me the sixth volume. I read the sixth volume and enjoyed it very much, but the third volume came later on. I was crying while I read the second volume and could hardly wait until I got the others. When I finished reading the six books, high mass came again on a Sunday morning. Mr. Berger said, Get ready for Church. I said, I am not a Catholic any more; I have found what the Catholic Church is. He said, Did those books put that into your head? I said, Yes sir. He then said, he wished he had burned those books in the furnace. I told him I was going to a Bible class that afternoon, and he said, If you do, I will put you out of the house with the books. But I continued going to the Bible Class. He tried all

kinds of things to get me back, and he is still trying, but the Lord has given me grace so far to stand, and I think I can stand to the end. So I was taken out of the fire of the Catholic purgatory and put into the symbolic fire, and I hope the logs of wood -- of which Mr. Berger might be one - - will burn and burn until the gold is purified, until the Lord gives me a vessel which will be of pure gold, and I ask the prayers of all the dear brothers and sisters that I may be faithful unto death.

At this point the Sisters Nation of the Bible House sang the song entitled, "Jesus is Mine."

A Brother: I am glad to hear the testimony of the sister from St. Louis, and that a tract brought her into the truth. We cannot all be pilgrims or colporteurs, but we can all hand out a tract.

Brother Rutherford: A number of years ago a lady called at my office and out of sympathy for her I bought a book. I did not want the book, had no use for it at the time, but afterwards I read it and came into present truth. And that dear sister is Sister Hettenbaugh who is here now. I rejoice that I had the opportunity of speaking with her yesterday.

Columbus Penitentiary: The brethren in the penitentiary at Columbus, Ohio, sent their written testimony, which was read by Brother Williamson.

Prayers: At all of the testimony meetings, requests were made by those who were passing through trials and difficulties, for the prayers of all the friends.

## **11 A.M. -- Discourse by Pilgrim Brother W. E. Van Amburgh.**

"As the Father hath loved me, so have I loved you: continue ye in my love" (John 15:9).

These words almost startle us. Their importance, their simplicity, their directness, and the revealing of a wealth of love, almost beyond our human comprehension. They were spoken by the Lord himself. This Lord had authority over the powers of nature, over diseases, and over demons. As the poet has so beautifully expressed it in describing some of these miracles:

*"The modest waters saw their God, and blushed;  
The boisterous billows heard His word, and hushed;  
The angry demons quailed and fled.  
At His command came forth the dead."*

Our Lord also had command of the use of language. Search all the pearls of speech and you will not find such lustrous pearls as fell from our Lord's lips. "God so loved the world, that whosoever believeth in him might not perish, but have everlasting life." Whoever thought of condensing God's great love into one crystal of twenty words. There it stands in all its beauty, in all its radiance so bright that the eyes of the world have never yet been able to look upon it with understanding. It is necessary for us to have the eyes of our understanding open before we can see this precious pearl in all its lustrous brilliancy.

"I am the true vine and my father is the husbandman; every branch in me that beareth not fruit he taketh away; and every branch that beareth fruit, he purgeth it, that it may bring forth more fruit" (John 15:1, 2). Dear brothers and sisters, it is necessary for us to have our eyes anointed with the eye-salve of truth to see what it means to be a branch in Christ. So in this priceless pearl which we have before us this morning, "As the Father hath loved me, so have I loved you." Can we compute the value of that equation? As we look back through the Word and see the great love which the Father had for His Son, He who had been given authority to bring forth all things that are, as the apostle says, that without Him was not anything made that was made; He was before all. He was the Lord of all, and the Father's well beloved Son. It pleased God to give Him great glory and honor, but hidden down deep in unfathomable mines of our Father's purpose was His plan to bring forth a blessing for all His intelligent creatures, and this plan was to be wrought out through an instrumentality, and He purposed that this instrumentality must be a great one. The last of His beautiful creation, mankind, had fallen; had gone down into sin and death, and there



was need of a mighty arm to save from destruction, and there was none to save; God said, "When I found none to save I stretched forth mine own arm." Who should be chosen for this mighty work of blessing all the families of the earth, bringing back those who had gone into degradation, into sorrow, into shame, into death? We might almost hear the Heavenly One say, Why surely our Lord would be the proper one, He has manifested His power, He has manifested His ability. But we read in the Word that it pleased the Lord to bruise Him. There was yet a field of battle upon which this One had not fought. There was a victory to be gained which this One had not yet gained, and it was necessary for Him to be a conqueror in all fields; and so we read that He humbled himself, He came down and was made man, He became flesh and dwelt among us. And the Scriptures inform us of the adversities which He had to meet; first was the great Adversary with His most cunning inducements, but as soon as our Lord recognized their Satanic instigation, He immediately said, "Get thee hence, for it is written, I came not to do my own will, but I came to do the will of Him that sent Me." Again, as He was met by the world, He refused to follow it, and only once during His career on the earth did our Lord seem to hesitate. Our Lord came to give His life, a ransom for many, but when He came to the Garden of Gethsemane, and saw all the ignominy, all the shame, and all the degradation, His heart seemingly hesitated. "Father I have humbled Myself; I chose not the great ones of this world for My associates; I have chosen some poor, humble fishermen, and I have not sought the course of this world; is it necessary for me to drink of the dregs of this cup of shame and degradation? Nevertheless if that is Thy will, Father, I prefer it." And again He came back and said, "Father, is it necessary?" Oh how that perfect human heart of flesh quailed before that sacrifice! And as He came back the third time, more desirous than ever before, seeking to know the Father's will, having ascertained it, He stepped forward as a conqueror and said, "Down pride, down; I came to do My Father's will. If it be My Father's will that I drink that cup to its dregs, I will drink it." Oh what a victory! That was a victory over self. There was a conqueror. "If My Father wishes me to drink of that cup, His love for Me is too great to ask one thing but what is for My good. I will drink it."

What does the Apostle say? "Enduring the cross despising the shame" -- and then what? He is now set down at the right hand of the throne of glory. Was He crowned as a conqueror because He had slain His thousands, and strewn the world with death, thereby becoming a conqueror of the world? No, He was crowned as a king because He conquered Self. The apostle again says, "Let this mind be in you which was also in Christ Jesus." Did he become obedient? Yes, our Lord learned obedience before He was placed in command; He learned obedience by the things which He suffered. He became obedient unto death, even to the death of the cross. Wherefore God has highly exalted Him, and given Him a name which is above every name, that at the name of Jesus every knee should bow, and every tongue confess. What does the Apostle tell us? Picture before our enchanted vision the future as he speaks of the great glory that shall come to our Lord, and what is the proclamation? "Worthy is the Lamb that was slain." He does not say, "Worthy is the Lamb that slew His thousands," or "Worthy is the Lamb that God used to bring forth all of His intelligent creatures." But "Worthy is the lamb that conquered self; Worthy is the Lamb that was slain to receive glory, honor, riches, wisdom and power." Oh what a conqueror we have. Think you not that the Father loved a Son like that? Think you not that Son loved His Father? And is there any wonder that it pleased God to set Him on high? Is it any wonder that God would honor so loving and loyal a Son? Can you compute the value of that love, or the strength of the tie that bound those two together? "As the Father has loved me." Dear brothers and sisters, we cannot compute that with our finite minds; it is too great for us. These words were spoken to the Lord's disciples just on the eve before His crucifixion, showing that on the morrow the Shepherd would be smitten and the sheep would be scattered. He realized they needed comfort; poor hearts, they could not understand the wealth of meaning of those words at that time. But afterwards, when they should receive the Spirit of Truth they would begin to understand what it meant, and then they could assure their hearts. And if God so loved the Son, and then the Son told us that He loved us, you and I can assure our hearts this morning from these same words, "As the Father hath loved Me, so have I loved you." But hold! Have we the right to apply that to ourselves? Our Lord was talking to His eleven disciples; He was not talking to you and to me. Who could be the recipients of such boundless love as that? Who would not delight to be the recipient of such love that no man could comprehend, such love as the Father hath for the Son? Who would not give all he possessed that he might be the object of such love as this overflowing love, love Divine? Who would not give all that he had, and all he ever expected or hoped to possess, that he might attain that position of favor in the heart of one whose heart was full of love. We say to ourselves, Yes, He was talking to the eleven disciples, and not talking to us? Is there not some way possible that I might become the recipient of such wonderful love? And may not the Lord have some love for me? Listen, brethren! "Father I pray not for these alone, but I pray for all them which shall believe on me through their word." O Blessed hope! Does that mean you and me? Have you and I believed on the Lord Jesus Christ through the Word which has come to us? Is there a possibility that we also might be recipients of such great love? Well there is a possibility, -- but wait! The Father is looking for conquerors, they must all be overcomers; "He that sitteth with me on my throne must be an overcomer even as I overcame, and am set down with my Father in His throne." Who am I? I have no great wealth; I have no great strength; I have no great wisdom; I have never created a universe; I have never done anything great or mighty, and the Lord is looking for conquerors.

Where can I go out and become a conqueror? Listen! Overcome as He overcame. How did He overcome? By faith. Within himself was the battlefield on which He conquered, and self was

what He conquered. Is there any possibility for you and me? We are not perfect, and we are not even accepted in the Father's presence as being worthy even to be counted as just; yet the Father in His great love has provided a way by which you and I may be covered with the robe of Christ's righteousness. He says, I will count you worthy. It almost seems as if the Father had loved us more than He loved Christ, when He would step down and from among all mankind select those who were lowly, and those who were unrighteous, and cover them with the mantle of righteousness. Our Lord did not need to be covered with a mantle of righteousness, for He was righteous. Having covered us with the robe of righteousness, we believing in Him, have made a consecration. I trust that everyone within hearing of my voice this morning has made that consecration. Then what comes? Then comes the battle, then comes the fight, and to be followed by victory if we are faithful. But of what does this victory consist? Does it mean that we shall become great before the world? Does it mean that we must go out and herald our greatness, and our knowledge, and our ability? No. It means that we have made a consecration, and that we are to conquer self. Some might say, Well I look at myself and see that I am not able to keep the covenant I have made. Oh yes, the Lord says I know that, and I promise you strength in every time of need; I will not only watch, but I will assist, and I will fully make up for every lack of yours. I will give you strength, and direct the issues of every temptation. Some of you have been on the battle-field for some time; some of you have had some pretty hard fought battles; you have met the Adversary at many turns, and by the grace of God you have been able to say in many cases, "Get thee hence Satan; I will not listen to your inducements, for I have found it written in my Father's word, and what I have found written in His word I have covenanted with Him to keep." You and I and many of us have met the world on many occasions and we have had some victories, and possibly some defeats; but the greatest foe we have yet met we found to be self. We have said, O if it could only be a little different, if we could only change this a little, if I did not have such poor health I could do this; if I only had a little more money I could do that, or if I only had the ability to get up and speak in public I would be so glad to do that; if I only had the ability to go out and colporteur I would be so glad to do so. Dear brothers and sisters, is not this self asserting itself? What did you covenant to do? I came not to do my own will, the Lord said. He might have reasoned "Well now, if I only had the power and authority I could do so much; if I were only seated in Caesar's chair, how much authority I would have, and how much more I could do." But the Father did not choose for Him to walk in that way. He might have said, "If I only had wealth I could build hospitals for the poor, and sick, and infirm, at the present time." But His father did not give Him the wealth; He did not have where to lay His head. He was the Lord of wealth, and had given wealth to thousands, and millions, and billions, of earth's creation, yet had not where to lay His own head. He humbled Himself. He may have said, Oh if I could get some of the great leaders of the present time, these Pharisees and Sadducees, to see this truth, and have them proclaim it. One time He was speaking to the Sadducees and Pharisees, and they could not understand, they could not comprehend, and realizing it was not the Father's will at that time, He said, Very well, Father, I thank Thee that Thou hast hidden it from the wise ones. If you have revealed it unto the babes, I will speak to the babes. I will not speak to the great ones of the world. Our Lord exemplified this opinion when He met the poor humble woman at the well; He had an audience of but one, and He lovingly explained to that one the way of life. The audience was not too small, even though it were but one poor woman, and, judging from the world's standpoint, she a sinner.

You and I might say, if this were different, and if that were different, I could do so much more.



Dear brothers and sisters, the victory is not measured according to how much work we do in the world. The victory is not measured according to the number of Dawns we sell, or the great numbers of sermons that we preach, or the influence that we may have among others, but the victory is to him that conquers self.

So we read, "To him that overcometh." Overcometh what? Overcometh self. "To him that overcometh will I grant to sit with me in my throne, even as I overcome and am set down with my Father in His throne." Dear brothers and sisters, you and I have a battlefield large enough to engage every ability that we have. We do not need to go out in foreign fields. We have opportunity for overcoming self in our own homes. We have opportunities for overcoming ourselves in our own neighborhood or wherever it may be. We might say, if I could only go on and give my whole time to the spread of the truth, that indeed would be a glorious portion. But it is the Father who has set every member in the body as it pleased Him -- not as it pleases the members. He did not agree to please the members, and tell them they could take their choice. It is a wonderful privilege for you and me to be found worthy to enter this body at all, and it is not for us to say what position we shall occupy. It has pleased the Father to set the members in the body as it pleased Him. Have I a position in the body at all? Is it true that this wonderful wealth of love may be mine that I should become a member of this body? I will not dictate to my Lord at all; I will say, Lord any place in your kingdom at all is so grand and glorious that I will accept of it most gratefully and thankfully, and appreciate the privilege of being found worthy of being a member at all; I will conquer self.

But your neighbors will speak evil of you. You used to be a member of a very fashionable church, and the neighbors looked up to you and said, That is Brother So and So, and that is Sister So and So; they are very fine members of our church; they give so much to the pastor's salary, and they are leaders in the Woman's Club, and the Men's Club, etc., etc. If I should desert all of them, and go out and meet with the humble little class, five or six or a dozen, whom the world considers common people, just think what they would say about me! They would cast me out as evil and begin to say all manner of evil against me. Can I do that? Can I bring myself down to that? Our Lord occupied a very high place in the Father's kingdom, but He came down here and made Himself of no reputation. Dear brothers and sisters, it costs something to make ourselves of no reputation. A good name is rather to be chosen than great riches. But a good name in whose estimation? Who is to sit as the final Judge on this question? Is it the world at the present time? Oh! the world says, Crucify them. But who is the final judge? Yes, I will leave these gorgeous worldly palaces, as I do not find my Lord there. I found my Lord down among these humbler ones. There is where I find the spirit of the Lord, and that is what I desire. I will cast out self, I will cast out reputation, and I will go and meet where the Lord meets. But self says, somebody is stepping on your toes; you tread back again; you get even with them; but the Lord says not to render evil for evil. Do good to them that spitefully use you; pray for them that persecute you. O what an humbling of self it sometimes means, when we get ourselves so far out of the way that we will forget that any indignity was offered to us! It is not to us that the indignity is offered. Suppose some one should hit my hand and hurt it; is the indignity offered to my hand? Is not the indignity offered to the head? Should the hand say, I will get even with you? Is it for the head to decide? And, therefore, we find in our Lord's word, "Avenge not yourselves." Get yourself so far out of sight that you will not recognize any indignity offered to you, or any evil spoken against you; it is not against you in fact, but is against your Head; it is against your Lord. And when we

can so far forget ourselves that we can get entirely out of self, and away from self, and keep self out of sight, and say, Vengeance belongs unto the Lord, -- when we are in that condition we are pleasing and acceptable to him.

Let us notice again how our Lord conquered. To the world it was the greatest defeat possible. In the estimation of the world it was a complete defeat, but it was the very means of victory. As the Apostle again says, "By this very thing we are conquerors." Conquerors over what? Conquerors over Self. Conquerors over the world, and conquerors over the Adversary. Yea, in this thing we are more than conquerors. We conquer the disposition to retaliate; we conquer the disposition to think evil, to speak evil, to seek for emoluments of this world, and to look for the pleasure and honor of this world; and we learn to keep self so completely out of sight that we see nothing except Jesus Christ and Him crucified.

"Continue ye in My love." Dear brothers and sisters, you and I cannot continue in any place we have never been. We must get there first, before we can continue. "He that dwelleth in the secret place of the Most High, shall abide under the shadow of the Almighty." If you and I have gotten into this secret place, the Lord says for us to abide there. Then He says, "If you love me, keep my commandments." Well who would not love so loving a Lord who laid down His life for us? Greater love hath no man than this, than he lay down his life, and He gave His life for you and for me. Let our minds go out for a moment to this wonderful bond of love which united the Father and the Son, and then by comparison put ourselves in place of the Son, and take the Son's Word, "And as the Father hath loved me, so have I loved you." We speak of faith, and we are told that it is by faith that we conquer. "According to your faith be it unto you." Dear brothers and sisters how much of that love can we appropriate to our own individual hearts through faith this morning? Can we apply that to our own hearts and say, "God loves me?" Can we make it a personal matter, "My God loves me?" "That the world may know the Father hath loved you, even as He hath loved me." If our hearts were full and running over of the love of the Lord Jesus Christ, we would never feel it if anybody stepped on our toes, or spoke evil against us; we would never turn to retaliate or get even. We would be so full of love for the Lord that we would not even mind those little light scratches. As the apostle says, "These light afflictions of the present time are not worthy to be compared with the Glory that shall follow."

Notice again, how did the Father love the Son? He exalted Him, and gave Him a name that is above every name. That is too high for you and for me to see at the present time, except by the strong glass of faith, looking away to the heights on which our Lord is a King, upon the very pinnacle of faith. It pleased the Father to place Him there, and the Son is now reaching down to you and to me, and says, "So have I loved you." Father, I will that these whom thou hast given me may be with me and behold my glory. They were thine and thou gavest them to me. Is it any wonder that the Apostle Paul who comprehended to a very large degree this wonderful bond of love, exclaimed, "Who shall separate us from the love of God in Christ! Do you know of anyone who can break this bond of love or separate us? Shall trials, or tribulation, or temptation, or the Adversary, or the world, or self, separate us? Every one of this noble company, the Father's family, will be conquerors, for every one shall overcome through the blood of the Lamb.

If there be any one thought in our minds during the Convention, let it be the thought of the wonderful love that God has for us, and the wonderful love that Christ has for us. Let us also

have this thought in mind: even as I have loved you." The Lord did not choose us because of our greatness, or because of our wealth.

He says, you did not choose me, but I have chosen you and ordained you, that you should go and bring forth fruit unto righteousness. You and I are given precious privileges of looking into the future a little ways. The Father has parted the veil and opened the eyes of our understanding, in order that we may know what is the hope of our calling. Glorious future that we have! Glorious vision, and glorious prospect! Glorious fellowship that we have, even on this side, for you and I are privileged to sit in heavenly places, in heavenly company, for the Lord has said, "I stand at the door and knock; if any man hear my voice and open the door, I will come in and sup with him, and he with me." The Lord is selecting your companionship and fellowship, why? Because He loves you. Who would not open the door of his heart to such a King if they would recognize Him, and see His glory and honor? But to you and to me are given the wonderful opportunities of looking into the future and seeing these precious things. The Lord has spoken through the prophets again of how much He loves us and says, "He that touches you, touches the apple of mine eye" -- a very tender spot in the human body. My dear brothers and sisters, the Lord would call our attention to how much He loves us, and again and again in the wonderful Word He has sent to us in this message of love, "God is Love." I trust that if you came to this Convention able to hold a quart, and you were full when you came, that you will go away from here able to hold a bushel and yet full, because His love is without measure. As we depart from this place, I trust we will have a larger comprehension of this wonderful love for us, and the precious privilege we have in Him at the present time, and that we will go forth determined that we shall be conquerors, and that each of us may be accounted worthy, as one of whom this may be said, "I have loved you, even as my Father hath loved me." I want to go from here with my heart more firmly bound to my Lord. I want to go from here with my determination increased, my zeal inspired, my faith strengthened, that I may be used of Him in any way that He please, that I may keep self entirely out of sight, that I may be a conqueror upon the battlefield. I know I cannot do it all myself, but by the Lord's grace which He has promised so bountifully to supply, I may yet be a conqueror. And may this prayer be in every heart, "Lord let me have the will to do Thy will. Not my will, O God, but Thy will. Even though it be a cross and a shame, let us despise the suffering at the present time, and look unto Jesus the author of our faith, and praise His name; He will soon be the finisher of our faith, because it will become possession, and possession is not faith.

May the Lord draw us closer and closer. "As the father had loved me, so have I loved you. Continue ye in my love." Amen.

## **"The Ten Stringed Harp."**

*11 A.M. -- While Brother Van Amburgh was delivering his address as per the program in the International Opera House, Pilgrim Brother Geo. Draper addressed an overflow meeting of over 600 in the auditorium of the Natural Food Co., on the subject: "The Ten Stringed Harp."*

Our Lord said, "I go to prepare a place for you" and we know that His place will hold all that will be there; there will be no over-flow at the general assembly of the Church of the First-born.



We wish to call your attention this morning to Psalms 33:2-3, and to talk to you a little while on something that you know about, The Harp of Ten Strings. We all recognize that,

God's word is that harp, which has long been unstrung,  
And men heard but discordant its notes;  
Now as tuned are its cords from Moses to John,  
How grandly sweet melody floats.

"Praise the Lord with harp; Sing unto Him with Psaltery and an instrument of ten strings. Sing unto Him a new song; play skillfully with a loud noise."

The Psalmist is taking the view-point of the entire Church when he says, "Sing unto the Lord a new song." We deny that we are singing a new song.

I wish to call your attention first to the harp and will enumerate the ten strings:

1. Creation
2. Condemnation.
3. Law.
4. Ransom.
5. Resurrection.
6. Justification,

Some one present may say, "Certainly you have the strings in wrong, you have resurrection in ahead of justification." I reply no; it would be impossible for our Heavenly Father to justify dead things. Resurrection must be ahead of justification. The whole world will be raised up, but not actually justified and then resurrected. When justified before God, they will be actually just. You and I have the privilege of being justified by faith.

7. Consecration or Sanctification.
8. Glorification.
9. Restitution.
10. Second Death.

All these ten strings we recognize are necessary to beautiful harmony on the grand old Harp.

God's Word is that harp which has long been unstrung. It is necessary for it to be in tune before the grand and sweet melody may float from Moses to John, and we recognize that God's Word is thoroughly in tune. We have heard the grand anthem, and know there is no discord from Moses to John. But the question arises in our minds, friends what is necessary in tuning the harp? And we answer, that the first thing necessary to tune any instrument is the tuning of the "A" string to concert pitch, and then you have a basis to work from, and you can work from A to G and the whole harp is in tune. But until the "A" string is in tune, you cannot tune the harp. We have an "A" string in this harp. If I ask you what it is, you would say the doctrine of the Ransom. "Other foundation can no man lay than that which is laid, which is Jesus Christ." That is the reason we have not heard very sweet melody from the old harp since the early Church fell asleep, because the "A" string has not been in tune. They accepted the doctrine of the Ransom without having the philosophy. So we see, friends, that it is necessary to have the "A" string in tune, and we are glad to recognize this.

Another thought connected with the harp is this: Who put the harp in tune? I am sure, friends, that there is no one in this audience that could put the harp in tune. Who did? The Master Musician Himself came forth at just the due time, and put the grand Harp in tune. I am glad that our dear brother Russell did not put it in tune. What did he do? He told us that it was in tune. And we thank God that we have ears to hear. Now recognizing that it is in tune, and that there is something further, the Master Musician handed it to us and said, Now you can learn to play. But, at our joy on hearing the Master, we misunderstood that he said we could learn, and thought He said we could play for the whole world. And we were disappointed when we found they did not like our music. Why? We were just entering the practice room and you do not like to hear anyone practice. We appreciated because we heard the grand anthem from the Master Musician Himself, but they heard only the discords of our practice. We are getting so near the Master Musician that we are getting grand music, and we know more about time now. When we began, we learned the strings, but now we know that there is time to all things. If there is no time it destroys the whole melody. Now we are commencing to understand that there is time (chronology) to all things.

When we were playing for the world of mankind, they said, "I do not see much of a tune to that." We were just commencing to learn. So from the time of entering the school of Christ, He has been giving us the opportunity to practice on this grand old Harp. And the world will not complain of our music when we have graduated from the school of Christ.

Here, speaking of the glad time that shall follow, when He says, "Sing unto the Lord and play skillfully," etc, the whole world will hear and be blessed by it. We are glad that our dear Redeemer has taken us into His confidence and given us this glorious opportunity to practice, that we may be able to play for the world of mankind in due time. We recognize in the teaching of the Scripture that the Lord's dear people are particularly interested at this present time in three strings, one is always excepted when we speak of God's word, -- the "A" string, the doctrine of the Ransom. We speak of three other strings that you and I are particularly interested in: Justification, Sanctification and Glorification. Let us call your attention to these ten strings again; we will enumerate them again, and you will recognize that we can see in every one that God is Love, and whoever dwelleth in Love dwelleth in God.

1. Creation: We recognize that in it all, God is Love.
2. Condemnation: In it we can recognize that God is Love. Somebody asks how? We recognize that when the heavenly Father placed our first parents on trial, and then condemned them, it was a JUST condemnation and we are glad. We recognize that if our heavenly Father had permitted them to live on and on in sin forever, what a terrible thing it would have been, but God has permitted Him to live for only thirty-three years. We are glad that God did so arrange the matter and in this we see that God is Love.
3. Law: In this we recognize that God is Love. How in the law? Because the law did not give anybody life. The Apostle Paul said the law was added because of transgression until the promised seed should come, so you see if it had not been added or given to the children of Israel and thereby holding them up higher than the majority of mankind the conclusion would be that at the Redeemer's Advent, not a man in the world would have known enough to receive the Lord. In this string we recognize that God is Love.
4. Doctrine of the Ransom: Here we all exclaim God is Love.
5. Doctrine of the Resurrection: In this doctrine we realize from our dear brother Harrison's lesson yesterday morning, that God is love, and in looking into God's word we recognize the great love manifested by our heavenly Father.
6. Justification: Certainly God is Love in justifying us freely and accepting of us as actually perfect, and accepting of our sacrifice. In this we can see that God is love. Then when we come to
7. Sanctification, we see how we have been set apart and given the privilege of running for this prize.
8. Glorification: This we cannot see much yet, but we can say truly God is Love because the Apostle John said "We shall be like Him when we shall see Him as He is."
9. Restitution: Acts 3:23, The heavens must retain Jesus until the times of restitution of all things spoken by the mouth of all the holy prophets. God is Love.
10. Second Death: Is it possible that this shows God is Love? We recognized in the other nine strings how our dear Heavenly Father will bring to bear upon the whole world of mankind His whole glorious plan, and, when done, we can recognize that God will be manifesting Love in cutting off any creature that will not be in harmony with those conditions.

So we are glad that in these ten strings "God is Love" and whoever dwelleth in God dwelleth in Love.

In Rev. 14:3, we read, "And they sung as it were a new song." David in the Psalms said: "Sing a new song," but the Revelator says, "Sing as it were a new song." They had forgotten that there was such a song. But since dug up in the morning of the Reformation, the majority of mankind

when they hear this song think it is a new song, and they say, "Where did you get hold of this? How long has it been out? I never have heard of it." It is as if it were a new song to them, but it is the old song of Moses and the Lamb. Few of the teachers today care anything about the song of Moses and the Lamb. The Revelator says that no man can learn that song. So we will not blame the world if they do not learn that song.

Again in Rev. 15:2, we read, "And I saw as it were a sea of glass mingled with fire; and them that had gotten the victory over the beast, and over his image, and over his mark, and over the number of his name, stand on the sea of glass, having the harps of God. And they sang the song of Moses the servant of God, and the song of the Lamb, saying Great and marvellous are thy works, Lord God Almighty; just and true are thy ways thou king of saints." There is another song going on just now, it goes something like this, and causes considerable confusion: "Great and marvellous are our works O Lord God, just see what we are doing." The Revelator and those that have the harps are not saying that; they are saying, as do the Scriptures. This is a great privilege at this time to be able to sing this song."

Verse 2 -- I wish to call your attention to this second verse: "I saw as it were a sea of glass." The authorized version says "Stand on the sea of glass." The revised version says, "Stand above the sea of glass." But the Diaglott says, "Beside the sea of glass." They were not in it but on the outside of it. They can look down through that glassy sea and can see God's Kingdom coming out on the other side. Those that are in the glassy sea cannot see, for it is mingled with fire and smoke, but we who are permitted to be on the outside of it, called out to the world our privileges to recognize God's glorious plan of the ages.

What is this opportunity given to us for, is the question before our minds. Are you attending to the three strings: Justification, Sanctification and Glorification? The first verse of the 5th chapter of Romans reads, "Therefore being justified by faith, we have peace with God through our Lord Jesus Christ." So we realize, friends, that there are several classes justified by faith. We will enumerate three of them: One class said, "I am glad I am saved and wish everybody else was." Another class says, "I am glad I have been saved, and if you will find me a position with \$1200.00 or \$1500.00 a year, I will try and save somebody else." Another class says, "Now, dear Lord, I recognize that I am not my own, I have been bought with a price; but now, Lord, what can I do to show my appreciation, not what will you give me. The Lord appreciates this spirit and high sentiment, in Romans 12:1: "I beseech you therefore, brethren, by the mercies of God, that you present your bodies a living sacrifice, holy, acceptable unto God, which is your reasonable service."

Now the apostle is beseeching you by the mercy of God, and if we now realize that, we will appreciate the mercy of God so much that when we hear the Apostles' words we will be sure to do this, it is our reasonable service. I want you to notice another thing, he does not say for us to present our heads, or our wills, or our minds, because you are so intelligent and have been in college, etc. No, He says, I want your bodies; I do not want your heads; I cannot use your head; I will give your body a head.

That is the reason the college professors do not hear, they have heads of their own, and they make a boast of it. It is only those who have been beheaded, and have the witness and testimony

of Jesus. All the knowledge of angels, and all the knowledge of the Universe, cannot make them hear. The Revelator says, "I saw the souls of them who had been beheaded for the witness and testimony of Jesus." If you have not been beheaded you have not the witness. So we realize we have now entered into Covenant relationship with our Lord, and from this time a warfare has begun. When we were justified by faith, there was no warfare; we were very glad that we had been justified. The old man could say, I am glad you do not do the things you used to do; you are a very fine gentleman now. The old man felt very good about that. Then came the second step, of Consecration, Then it is the old man says, You are getting radical; people will say you are getting foolish about it. We must lay aside our own wills in the service of the Master, and then we find the warfare begins, and we will have to fight the good fight of faith more and more. At first we did not recognize but that everything was going all right, at first we might have thought we were not in the school of Christ, but we were quietly laying a foundation for the superstructure of our faith. You were given an opportunity to lay this foundation, and after that you could recognize that you were in the school of Christ, and then you commenced to go up higher and higher. And the higher we get in the school of Christ the harder we have to study, because the lessons are harder. And it is necessary for us in the school of Christ to show ourselves approved unto God. Not for today only, or for tomorrow, but approved forever afterward. It is a life study. We must study to show ourselves approved unto God. At this present time, in this day of rapid development, I have known of several instances where children have graduated at the ages of thirteen and fourteen years; they were physical wrecks and mental giants, and these do not go well together. But the Lord wants us to be physical wrecks and mental giants, and that is the reason we should study to show ourselves approved. Should we not rejoice that it is possible for young people to acquire an education in such a short time? We thank our heavenly Father for the privilege of finishing our race in such a short time.

In starting in this narrow way of sacrifice, we commenced to lay aside all immorality as rapidly as possible, and realizing this more and more, we see what we have consecrated is our justified nature; the old man is supposed to be dead; we crucified the flesh with the affections and desires. That is not what we consecrated. We consecrated our justified nature. One old brother once said he had consecrated his tobacco to the Lord. I said, no, the Lord has not use for it; thank the Lord you have gotten rid of it. We consecrate the things that are perfectly right and legitimate for a perfect human being to do. We realize that there certainly is a warfare and every day it is becoming more and more intense because we are coming to a higher standard, and look at things from a higher vantage ground. We look at things from the same standpoint that our Lord is looking at them. Every day we come to certain things, and we ask, "Is it wrong for me to do this?" It is not a question of right and wrong; the very fact that it has come between you and Him shows that it is wrong. We want to say, "I want to see Jesus," and should allow no earth-born cloud to arise between Him and us. Then we see from this standpoint that we are walking the narrow way of sacrifice, and we are getting more and more like the Master. Do we try to do the will of God, which is our sanctification, our setting apart? Let us keep this in memory and not ask ourselves if it is wrong, or if it is right, but rather is it glorifying our heavenly Father? As the way gets narrow, are we glad? Yes, we are glad, because we are looking at things more from God's standpoint than we ever did before; we are standing on a higher vantage point; we are running for the prize of the Truth and its honors. Are you doing this, dear friends? That is the reason our Lord is giving us these opportunities and permitting us to assemble together, especially as the day approaches, that we may become more like Him, and lay aside every



weight, and say, "I want to see Jesus, for it is the greatest desire of my life." So if anything comes between us, we will lay it aside. The very fact that you saw it, is because it was in your way, for if it had not been in your way, you would not have seen it. We can rest assured, dear friends, that our Father would not permit us to see anything if it was not in the way. God gives us the opportunity of setting it entirely out of the way. From this standpoint we realize that we must fight the good fight of faith; it means more, dear friends, than merely a profession, it means more than saying we will be dead.

This calls to my mind an instance when I left the Baptist Church some twelve years ago. They were very much concerned and sent committee after committee to me to get me back, others who joined the church at the same time I did were going to dances, etc., but they did not send any committee after them. But because I was studying the Bible, they thought I was in the most dangerous condition of all. One day the minister came to me and said he wished I would burn up the books and come back. I told him I could not burn up the books, but if he could show me where they were wrong I would burn them up in his presence. He opened the Bible to the 16th chapter of Luke -- the parable of the rich man and Lazarus. He claimed it was all a literal statement, and he said, reading, there was a certain rich man who wore fine linen and purple; the rich man died and was buried. "Don't you think that is so?" he said. "I certainly do," I replied. He then read, "Being in torment he lifted up his eyes." "Then he was not dead at all, was he?" "Yes, most assuredly." "Well, you could not make me believe you were dead if you lifted up your eyes." We think our "old man" is dead, but once in a while he lifts up his eyes. This is a life work of crucifying the "old man;" our life work is in pressing down upon the mark for the prize of the high calling in Christ Jesus. And if so, we must be at the mark, so we see that when we reckon ourselves dead, it is only reckoned dead, and we must keep our eyes on the "old man," but we must not put all of our time in with him; not any time, in fact, but just keep an eye on him. If he can keep us putting all of our time in with him, he is satisfied; do not give him one particle of time. When worrying about the "old man," that is what he wants us to do, for then we will not do anything else. We are to put our confidence in the dear Redeemer, for as our dear Brother Sullivan said, "We have lost all our identity, our wills, ideas, etc. They have been taken away, and we are new creatures, and have lost our old identity. Do not put in any time with the old identity; keep your eye on him, but not your mind."

Pressing down on the mark. So if we are at the mark, it is a life work now; it is keeping down every root of bitterness coming into our heart, and if we are not at the mark, there is something between us and God. We must watch continually, and while watching we must remember one thing; the Apostle said, "Pray without ceasing." And while watching pray continually, and after having done all, we recognize that it is our Heavenly Father that is doing His good pleasure; we are not doing it; the Heavenly Father has promised that we will finish the work He has begun in us, and that all things will work together for our good. We need the faith that our Heavenly Father is working in us, and that we need Him and not that He needs us.

I remember the first day in this city a gentleman said to me, "You people have such different views from any other people I have ever met; you do not harp on the things we ought not to do." I said, "My friend, the Lord tells us what we ought to do, and if we do that, we have no time for the things we ought not to do." Cast all your confidence on the Lord; that is where our confidence is. If we do this, then we will run with patience the race set before us. If not running

with patience, we are not running right; we must not only run, but with patience, and believe that God is working in us to will and to do His good pleasure. I remember a dear old brother in one of my Pilgrim trips in the southwest. I asked a question to a class of about sixteen or eighteen of the Lord's people. How many here can conscientiously testify that you have reached the mark? They looked very surprised. This old brother said, "I have all the evidence in the world that I have not yet." I replied, "You have too much evidence, and it is in the world." That is not where our confidence and faith are. No, no. I asked, "How long have you been in the truth?" "About sixteen years." "How much longer do you expect to be in the race, now that you have been in the race sixteen years and have but five or six years to finish your course --- how much time do you expect to put in, standing at the mark?" He replied, "I am badly discouraged on the question." We called attention to the four quarter marks; the first is love for God. That is easy, but it is another thing to manifest your love. Second, love for the brethren. That is easy many times. Third, love for the world -- a sympathetic love. Fourth, love for our enemies. Here the English language limps when it tries to explain spiritual things. Our Father did not take us to this race course and test us at each point -- at the first, then at the second, etc. No, He has been testing us all along at these lines. You there laid aside every weight, but there was something more for you to do; were you to put on the whole armor that you might be able to run? No but after having done all to stand. So I said to this dear old brother, "Have you enemies?" "Yes, I think I have." "Do you hate them?" "No, I would not hurt them." "Would you do them good if you had the opportunity?" The dear brother was overlooking the fact that it was the heart condition the Father was looking at. God will do good to His enemies in due time. This dear old brother had reached the mark, and did not know it. He does know it now, and is not discouraged. So, if it is necessary for us to know where we are on the stream of time, so it is necessary to know where we are on the race course. Our Lord has given us to know where we are on the race course. Do not examine the world, or your enemies, for there you will find trouble; but look in your heart to see if you have love for your enemies and for the world, then you will know where you are in the race course. Do not set your affections in the world, but in the Lord, then you will see that the Lord will test you along the various lines. He is testing us along all the lines.

My experience was this: The day our Heavenly Father took me up to Pisgah's Mountain and showed me the grand panoramic view of the Plan of the ages, I tried to make the world know it, but I had not learned time, and could not play on the Harp. The dear Lord took me up to the Mount and showed me the Plan, and I am sure I had love for God, and the brethren, and the world, and for my enemies; but God said to me, "I cannot take your word for this, I must see whether you have love or not." And He has been proving me all this time. I thank God that with my heart, my mind, my intention, it is my desire to serve God. We will not be satisfied, knowing where we are will not help us up, but if rightly exercised we will be humble; and in place of being puffed up, we will realize our time is short and we will press down more and more upon the mark and bring all into subjection to the will of God. Knowing this in place of being puffed up, we will be more and more humble and get more and more at the foot of the cross, and realize that there is nothing but the power of Jesus that will lift up. It is not of him that willeth, or of him that runneth, but of God. We will have more and more opportunity to receive the approval of our Heavenly Father. Then with confidence in the Lord, and not confidence in others, we will hang on to this grand and glorious anchor that is cast safe within the vail, and then we will press down upon the mark of our high calling in Christ, and we will be able to hear that "Well done, good and faithful servant; thou hast been faithful over a few things; I will make you ruler over many."

This is the earnest desire of all here; and this is our earnest desire in coming to this convention – not because we were so anxious to see the Falls; our attention has been called to something grander and greater. We came to Niagara because we believed it was the Lord's will that we might continue to press down upon the mark for the prize. Let us be sure that all the sluice-ways are open, so that we may receive all the blessings the dear Lord may see fit to give us. Maybe He will not use the best means that you might think, but our dear Redeemer is using the very best course for you. So if there is a speaker in this convention that does not measure up to your ideas, do not think for a moment about the speaker, but of the Lord of the harvest. Do not see how much you can find fault, but see how much good you can get. We came to be filled with the Lord's Spirit, and if not, there is something wrong. If there is a root of bitterness or a desire to be prominent, let us remove all such that we may go home from this convention with a stronger and a greater desire to run with patience the race set before us.

## **2 P.M. -- Praise Service.** **Baptism Service.**



View from below Tents.

As neither the Auditorium of the Natural Food Company nor the International Opera House were large enough for all who wished to hear Brother Russell give his discourse on Baptism, and to attend the immersion service, it was decided to have both the baptism discourse and the immersion service in

the open. Accordingly arrangements were made with the officials of the Government Park, which runs along the bank of the Niagara river, to use the Park for said services. In the Park is a lagoon running parallel with the Niagara river. The river itself would be a dangerous place to have such a service, but the water in this lagoon is comparatively quiet. On one bank of the lagoon, two tents were erected, one for the sisters and one for the brothers; matting was laid from these down the bank of the lagoon to the water's edge. A canvas was also sunk to the bottom of the lagoon to protect the feet of the friends.

Then two large committees were appointed, one for the sisters and one for the brethren, to look after the interests of those that were to be immersed. Each member of these committees had his or her special assignment of the service, and as a result there was no confusion or friction, notwithstanding the great amount of work connected with the immersion of such a large number

at one time.

On the opposite side of the lagoon, the ground rises to quite a height. On the side of this sloping bluff, which served as an open-air amphitheater, the friends were gathered while listening to Brother Russell deliver his wonderful discourse on Baptism. He stood at the foot of the bluff and those expecting to be immersed were seated on the ground near him.

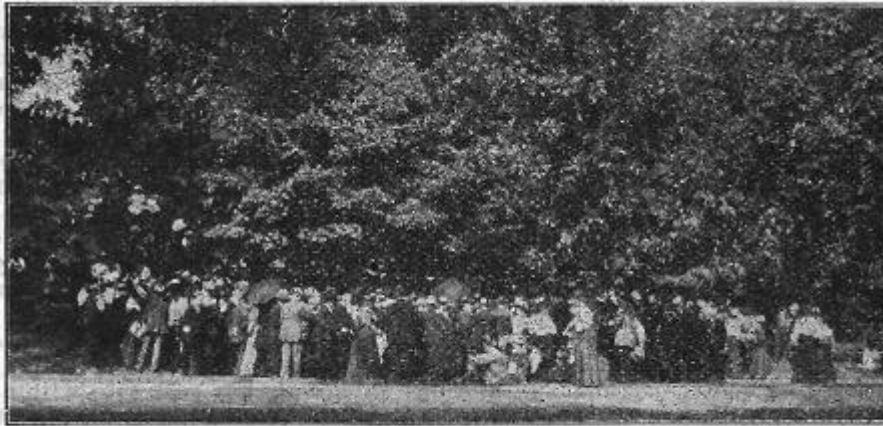

Gathering of Friends.

We were all reminded of the early days, when our Lord addressed the multitudes in the open and near the water.

Brother Russell's discourse was listened to attentively, but inasmuch as the subject of baptism is fully treated in the sixth volume of Dawn, space will not be taken here to print the discourse.

At the close of the discourse, the multitude proceeded about a block farther down the lagoon where the tents were erected. Near the spot where the immersion took place was a rustic stone bridge, and those intending to be immersed crossed this narrow bridge (it was spoken of as the narrow way which separated them from the world.) At the farther end of the bridge, the friends were greeted by Brother Russell and Brother Williamson, and given the right hand of fellowship.



Naxos Falls, N. Y. - Willow Island.

The friends intending to symbolize, by water immersion, their consecration even unto death, were soon ready and then began one of the most impressive funeral services ever held. Two brethren assisted the friends down to the water, where they were received by Pilgrim Brother J. A. Bohnet, who served them in the immersion. After being immersed, the friends were assisted to the bank by another brother, where they were helped out by two others and then escorted to their respective tents. In the case of the sisters, they were received on the bank by other sisters,

who, with willing hands, threw another robe around them and assisted them in every way possible.

Thus, in the short space of 105 minutes, 241 dear brothers and sisters symbolized the burial of their wills into that of Christ.



*View from above Tents.*

While this was in progress, two thousand of "like precious faith" were gathered on the hillside, across the road which runs by the lagoon, singing hymns and commenting on the wonderful scene.

Soon after the services began, some outsider, probably thinking he could stop the service, put a quantity of chemicals in the water above where the immersion was taking place. Soon the water became very purple, but, strange to say, as the poisoned water came near the dear ones in the lagoon, the current carried it to the opposite side and around those in the water. Thus, the Lord sees to it that "no weapon formed against thee shall prosper." Four paper bags of the chemical were fished out of the lagoon, and soon the water became clear again.

We would be glad, were it possible, to reproduce that wonderful scene, but will have to leave it to the imagination of those not present, to form some conception of that glorious service.

## MONDAY EVENING, 7:30 P.M.

BROTHER WILLIAMSON: I cannot refrain this evening, before the meeting commences, of speaking of the precious service which we had this afternoon. It was one of the most impressive, one of the most solemn, one of the most blessed experiences I ever had, and I am sure this is the testimony of all those who witnessed that glorious spectacle on the banks of the Niagara river. The sight of that vast concourse of people assembled on the sloping bank, and the dear ones as they were being immersed in the water, representing their full consecration to the Lord, was one to fill our hearts with exceeding joy and solemnity. Our dear Brother Russell was well pleased with the whole arrangement, and after the service was over, he was exceedingly moved as he talked about the matter. There were 241 of the dear ones who thus symbolized their full consecration to the Lord, and as we extended to them our hearty greetings and handshakes, it was with the earnest hope that they might be loyal to the Lord, full of faith even unto death, that in due time they may reap the reward of the crown of life in the Kingdom.

Now we have with us this evening, dear friends, our beloved Brother Johnson. For a long time he has been traveling in the West and we have been very sorry that we did not have larger opportunities to greet him and hear him. We will now have the pleasure of hearing from his lips the blessed testimony of the Word.

### Brother Paul Johnson.

*"Walking in the Spirit, the preventive of walking according to the flesh."*

Our text is recorded in Galatians 5:16: "Walk in the spirit and ye shall not fulfill the lusts of the flesh."

The eternal destiny of almost everyone in this room will be fixed within eight years' time. This thought is one freighted with a great deal of solemnity, yet, dear brethren, it is, nevertheless, true.



Every spirit-begotten person in this building will have his eternal destiny fixed within about eight years' time. With a thought like that on our minds, surely the admonition is, "Speed thee, O my soul, on thy course." Either it will be in the divine nature as a member of the little flock, or in the great company, which is another spirit nature, or in the second death. One of these three things will be the destiny of every spirit begotten one in this room. Oh how solemn and how weighty the thought! How, with earnest yearning in our hearts, we ought to be impelled to walk in the spirit in which we have been begotten!

In order that we may become members of the little flock, it will be necessary for us to be more than conquerors through Him who has loved us. Nothing, therefore, is of more importance to us than overcoming. It is a problem

of special practicability to everyone of us. We cannot think of anything more important. Helps along this line will be of more importance to us, probably, than along any other line. And we want to give tonight, as the Lord's mouthpiece, a number of suggestions that will enable us better to overcome; that will, if followed out, secure the making of our calling and election. May our dear heavenly Father bless our speaking and our hearing, that it may prove fruitful in our hearts and in our lives.

The secret is given in our text: "Walk in the spirit and ye shall not fulfill the lusts of the flesh." Something is to be overcome. It is the flesh, as far as our text has reference to the matter of overcoming. We might speak of overcoming the world, and of overcoming the Adversary, but our attention tonight will be more directed toward our overcoming the flesh. We want to use as our subject, Walking in the Spirit, the preventive of walking according to the flesh.

We want to define the terms of our text, and then, with certain explanations, apply it so that everyone of us who is in the spirit may make such use of this matter as daily to apply it, and from this daily application, become renewed more and more in the mind of our blessed Lord and Savior, Jesus Christ.

By the flesh, primarily, we understand our inherited disposition -- that which we receive from our natural birth. Originally, father Adam and mother Eve had perfection of faculty of heart, and of mind, and of body. This same perfection was found in our Lord and Savior, Jesus Christ, but none of us come into this world in such a condition as that, but rather, as the Psalmist says, "Behold, I was shapen in iniquity; and in sin did my mother conceive me." And thus all the faculties of our heart and mind have been in some manner distorted. The self-loving faculties in some have been distorted, the social faculties in others have been distorted, and the animal faculties in still others have received more distortion than the intellectual and moral faculties; but all of them have been more or less warped and twisted by nature, and that is what we mean, primarily, by "the flesh" -- this condition in which we now are by our birth, the lack of the image of God, the lack of that original perfection in which father Adam was, and in which our Lord and Master was as a human being.

Then, in the second place, by "the flesh," we understand, the acquired disposition. This natural disposition works out along the lines of its nature. Just as lead must fall downward, so the natural disposition in its tendency is downward. And on that account as our faculties of heart and mind exercise themselves, being under the control of the selfish disposition, they more and more develop in selfishness, and thus this acquired disposition becomes what the Bible terms "the flesh," as the word is used in our text.

This is developed in two ways (1) Our surroundings have a large effect on that which we receive by nature, and, not being aware of what character development and development of disposition are, we grow up more or less the creatures of our environment. (2) Then education enters in very largely as another modifier, and the environment being evil, and our education naturally being of a kind not in harmony with the Father's will, the mind and the heart are still further turned away from perfection. This lack of perfection, therefore, whether inherited or acquired, is what the Scriptures mean by the term "the flesh."

Let us hear how the Lord's Word speaks on this matter: Romans 8:6: "To be carnally minded is death." Romans 7:18: "For I know that in me (that is in my flesh) dwelleth no good thing." Romans 8:3-5: "For what the law could not do, in that it was weak through the flesh, God sending His own Son in the likeness of sinful flesh, and for sin, condemned sin in the flesh: that the righteousness of the law might be fulfilled in us, who walk not after the flesh, but after the spirit. For they that are after the flesh do mind the things of the flesh; but they that are after the spirit, the things of the spirit." "The carnal mind is enmity against God, for it is not subject to the law of God, neither indeed can be" -- because of being out of harmony with His heart and mind. So we find the Lord telling us, in Gal. 5:17, the verse following our text, the same thing: "For the flesh lusteth against the spirit and the spirit against the flesh: and these are contrary the one to the other; so that we cannot do the things that we would." And thus, we see, we have by inheritance, and by development, a nature contrary to that of perfection, and it is with this nature that our contention and our fighting must be.

Our text uses another term -- "the spirit." Walk in the spirit. What do we mean by the spirit? What does the Lord's Word give us to understand is meant by that term? In the first place, the new creature is that which is begotten of God in us. It is not a new Willpower, that is, a new faculty through which we will; it is rather a quality imparted to the faculty that we now have, -- a quality of spirituality, a quality that is capable of receiving spiritual things, of aspiring to spiritual things, -- a quality so strong that it moves us to lay down that which is dearest to us as human beings in order that we may attain that which is the goal and the aspiration of this quality. We call it the "new will," the "new creature," the "new man." These are some of the expressions the Lord's Word uses in regard to this.

Let us see some of the testimonies of the Lord's Word on this subject. We find it called "Christ" in a number of passages. Romans 6:3: "Know ye not, that so many of us as were baptized into Jesus Christ were baptized into His death." The New Creature is here meant by the word Christ. The anointing which we have received from God, that which made Him Christ is given unto us. Put on Christ. Therefore we read in 1 Cor. 12:12, 13, as follows: "For as the body is one, and hath many members, and all the members of that one body, being many, are one body, so also is Christ. For by one spirit are we all baptized into one body, whether we be Jews or Gentiles, whether we be bond or free; and have all been made to drink into the one spirit." We receive and appropriate the one spirit. So in Gal. 3:26, 27, we read: "For ye are all the children of God by faith in Christ Jesus, for as many of you as have been baptized into Christ have put on Christ" -- have been begotten again, receiving this new heart, this new mind, this new will. Therefore we read in 2 Cor. 5:17, that "If any man be in Christ he is a new creature." The other passages tell us that we come into Christ by baptism, immersing our will into His will. "Therefore, if any man be in Christ he is a new creature; old things are passed away; behold, all things are become new." This same quality is called Christ in Col. 1:27: "Christ in you, the hope of glory." And in Rom. 8:10: "And if Christ be in you, the body is dead because of sin; but the spirit is life because of righteousness." And our Lord refers to it in the same way, though not using the word Christ. John 14:20: "At that day, ye shall know that I am in my Father, and ye in me, and I in you." The same thought we find in John 17:23 and 26: "I in them, and thou in me, that they may be made perfect in one; and that the world may know that thou hast sent me and hast loved them as thou hast loved me. And I have declared unto them thy name and I will declare it: that the love wherewith thou hast loved me may be in them, and I in them."



So these passages indicate to us that the new creature, the new heart, the new mind, is the Christ in us, the hope of glory, and this is what we mean primarily by the "spirit," as the word is used in our text. That new heart, that new mind, that new will, lays hold on the faculties of our heart and mind, and makes use of these for its own purposes; and as it continues to lay hold on these, using them as the agencies through which it operates, it gives them qualities like its own. And thus, under this constant habit of rulership over our faculties by this new heart, this new will, there is given to our faculties a bent, a direction, a quality, like that of this will which we receive in the begetting; and this is the secondary sense in which the Bible uses the word "spirit." You will find a large number of passages giving us this thought. It is the acquired disposition, therefore, that comes through the exercise of this new will which we have received from our Heavenly Father. This is the secondary sense in which the word "spirit" is used in our text.

Let us see what the Lord's Word has to say on these matters. Romans 13:4: "But put ye on the Lord Jesus Christ, and make not provision for the flesh, to fulfill the lusts thereof." Here those who are already begotten of the spirit, who have already put on the Christ in this primary sense, are exhorted to do something further, and that is to simply bring into subjection the will of the other faculties, so that these might be charged with the same spirit as is in this new will.

2 Cor. 4:16 -- "For which cause we faint not; but though our outward man perish, yet the inward man is renewed day by day." Verse 18: "While we look" -- notice it is not done in everyone, but "while we look not at the things which are seen (the things of the flesh, earthly things) but at the things which are not seen."

Eph. 4:24 is another passage to the point: "Put on the new man." Those who already have the new mind in the sense of the new will, are exhorted to put on the new man, "Which after God is created in righteousness and true holiness." The 8th chapter of Romans has much to say of the spirit in this sense, -- verses 6, 9 and 15: "To be spiritually minded is life and peace." "Now if any man have not the spirit of Christ, he is none of His." "For ye have not received the spirit of bondage again to fear; but ye have received the spirit of adoption, whereby we cry, Abba, Father."

Gal. 6:1: "Brethren, if a man be overtaken in a fault, ye which are spiritual, restore such an one in the spirit of meekness; considering thyself, lest thou also be tempted." Here it is called the spirit of meekness. This is a further development of the will of God in us.

In 2nd Tim. 1:7, a number of names are applied to it: "For God has not given us the spirit of fear, but of power, and of love, and of a sound mind." How is this done? By the new will -- the Christ in you as we use it in this definition, that which is begotten of the Father in us, -- laying hold on our faculties, and by exercising itself through them, charging them with its own disposition. And this is a daily work, being renewed in the spirit of your mind, becoming conformed unto the image of Him. God has predestinated us to be conformed to the image of His own dear Son, that He might be the first born among many brethren.

The creation of this will, this spirit, in us, occurs through the Word of God. James tells us in the 1st chapter, 18th verse: "Of His own will begat He us with the Word of Truth." The same

thought is found in 1 Pet. 1:23: "Being born (begotten) again, not of corruptible seed, but of incorruptible, by the word of God, which liveth and abideth forever." How? Our Heavenly Father, through the preaching of His Gospel, through meditation on His Word, permits the Word of grace to rest on our hearts and minds, and as our wills lay hold on the heart and mind, -- the justified will, the will that loves righteousness, the will that desires to love God with all the heart and mind and soul and strength, and the neighbor as one's self, -- that will, laying hold on these thoughts, more and more becomes charged like the thoughts. God, through the precious promises which He lets rest on our minds, draws us to Him until finally we are drawn to lay down our lives in His hands, that He might dispose of us as seemeth good in His sight. And when this is done, -- the drawing through the exceeding great and precious promises, that through these we might become partakers of the divine nature, we assenting and God accepting the surrender, -- this new will, by a creative act of God, by the Word that has been resting on our hearts and minds, is made, and thus we come into existence as new creatures.

### **The Mind of the New Creature.**

This spirit, as we read of it in our text, is to become like God. It has been begotten of God's will; it has been begotten through God's Word, and that Word of God is simply the expression of God's heart and mind to usward along the lines of His plan. Having been begotten of this, it partakes of the character of the Lord's Word, and that character coming from God's character naturally develops in us a character like God, and thus the primary purpose of the new creature in its development is to become like our heavenly Father.

"If I in Thy likeness O Lord, may awake,  
And shine a pure image of Thee,  
Then I shall be satisfied when I can break  
The fetters of flesh and be free."

This is the longing, this is the aspiration, of the new heart and mind which our heavenly Father has implanted in us.

There is another purpose that it has, desiring, first of all, to be like God. This being the holy ambition of this heart, it wants to commend God to others, and therefore wants to reflect God to others. Again the Apostle calls our attention to this in a number of passages. 2 Cor. 3:18: "But we all, with unveiled face, beholding as in a glass the glory of the Lord, are changed into the same image from glory to glory, even as by the spirit of the Lord." And in the same chapter he tells us this is that we might be epistles of Christ, known and read of all men. "Herein is my Father glorified, (credit is reflected upon Him before others) that ye bear much fruit." (John 15:8).

### **The Sphere of the New Creature.**

The sphere of the new creature is in spiritual things. It is not concerned with natural things further than that it would use them as its servants to express its life and ambitions. Apart from that, it would have nothing to do with the earth and earthly things. Its design is Heaven; its aspirations are heavenly; its desires are heavenly; its hopes are heavenly; its Father is heavenly;

its elder Brother is heavenly; its home is heavenly; its citizenship is in heaven; it tends heavenward, and everything it does, everything it desires, is for the purpose of having the heavenly mind, that thus it might be fitted for the heavenly body.

This new creature acts consciously. It is not driven about by every wind of emotion, nor of blind chance, nor of accident. It fully lays hold on what it has, consciously acting upon these things for its end, and that is why it develops character; character is never developed by those who float; those who drift with the tide, who float with the stream, never develop strength of courage in heart and mind to stem the tide, and by a conscious exertion of will-power seek to attain their goals, their ambitions, who put everything else aside that would be in the way of these, -- only those develop a settled, a fixed, character; and it is with those that God deals; and these are they that have what the Apostle calls in our text, "the spirit."

You notice there is a figure used in the text; he speaks of walking in the first part of it -- "Walk in the spirit, and ye shall not fulfill the lusts of the flesh." The second part of the text does not continue the figure, but let us, for the purpose of comparison and contrast, keep up the figure: "Walk in the spirit, and ye shall not walk according to the flesh." Notice the Apostle does not say, "Walk in the spirit, and do not walk according to the flesh, and do not fulfill the lusts of the flesh." But he makes a simple statement, and tells us the rest follows of itself. Walk in the spirit, then, the rest will take care of itself -- "ye shall not fulfill the lusts of the flesh."

### **The Fleshly Life.**

The fleshly life is a journey. It begins with our birth -- very little, however, and yet the natural disposition shows itself very early in infant life. As selfishness exerts itself more and more, the more and more does this fleshly walk show itself. The Bible uses this term of a journey with regard to the fleshly life. "Wide is the gate, and broad is the way, that leadeth to destruction, and many there be that go in thereat." And it speaks of those who walk thereon as having feet. "Her feet go down to death; her steps take hold on hell." (Matt. 7:13; Prov. 5:5) This walk is a very easy pathway; the person simply floats, or does that which is in accord with his inclination, natural or acquired, and that makes the way easy. He learns to take five different kinds of steps on that journey.

The first is self-indulgence -- to give away to self, to do the things that are self-pleasing, self-satisfying, and for self-aggrandizement.

The second step is self-meditation; meditation on the things of the flesh. The flesh loves to think of things in harmony with its nature. Therefore worldly things, and worldly thoughts, whether sinful, or naturally right, occupy the minds of this class. And this shows itself in a worldly occupation, and ambition to carve out success for self in the worldly occupation. That which is at the bottom of all natural man's acts is self. He cannot get away from self. No one can get away from self until he has something else to joy in besides self. And therefore no one rids himself of self, or has anything else but self in him, in ultimate analysis, except those who are begotten of the spirit of God. Therefore the disposition of the self-love will assert itself. It will depend on the general tendency, and the general disposition of the person, as to what object he will seek in life, and the methods and means whereby he would seek to attain the object; but we may be sure that

the characteristics of the flesh will show themselves in some way markedly on the surface, and in others less markedly. In still others it would be almost hidden. But we may be certain if one is in the flesh, he is of those that cannot please God, and therefore these characteristics will be along fleshly lines. They may be admirable in the sight of men. Men might applaud them. But from God's standpoint, in them dwelleth no good thing. And that will move them therefore to shirk everything that is against fleshly-love, fleshly-joy, fleshly-hope and fleshly-prospects.

They also take the steps of meditation on natural things simply, and on the natural character, and the natural occupations, and the desire to hold to natural well-being and good.

These are the five steps whereby this class marches on the broad road leading to destruction.

### **The Spiritual Journey.**

On the other hand, when we look at the spirit, we find that it is on a journey. The Scriptures use the same language with regard to the spiritual class that it uses in regard to the earthly class. For example, they are spoken of as being on a journey. Matt. 7:14: "Because strait is the gate, and narrow is the way, which leadeth unto life, and few there be that find it." Then again: "Thy Word is a lamp unto my feet and a light unto my path." "Walk in the light." "Walk in love." "Walk as becometh the children of God." So then, the Lord's Word assures us that we are on a journey. And this is the journey of which the Apostle speaks in the text, "Walk in the spirit." This journey is a very difficult way, for every tendency of the natural man must here be resisted, as it would express itself in self-indulgence, and in the meditation of natural things simply, in a natural character, in a natural occupation, and in the desire to hold to natural well-being and good. So the new creature must develop this walk along five steps:

The first step is self-denial, the devoting of the self-will unto death. Everything that pleases self in the place of God, or in the place of God's cause, is in the way of the new creature, and so far is a hinderance to one who is walking in the spirit, and therefore must be overcome.

In the next place, meditation on our Heavenly Father's Word must characterize these. This will be the second kind of step they must learn to take. They will have also to learn to take the step of "Practicing the Lord's Word," then the step of "Spreading the Lord's Word," and then the step of "Suffering for the Lord's Word." Each one of these steps in turn will be learned by the new creature who comes off a more than conqueror through Him who loved us.

The natural soldier takes quite a number of different steps. There is the normal step, there is the double-quick, and then when a certain part of a line is marching around a corner, the soldier at the near end must learn to take a very short step, while the one at the far end must take a very long step. As in the natural life, so in the spiritual life also, different kinds of steps must be taken. And walking in the spirit is along the line of the five steps we have indicated. It is difficult. O, dear brethren, every one of us who have been walking in this narrow way, who have been seeking to walk according to the spirit, can give testimony that it is a difficult way -- and some of us with sighs and tears. The spirit has its joys, but the difficulties are brought about through the oppositions of the flesh. And while we delight in spirit to fulfill the Lord's Word, and to take these five steps, counting it a holy privilege, the flesh succeeds in bringing in our way such

hindrances as would overthrow us unless they themselves be overthrown.

### **The Spirit and the Flesh in Opposition.**

That brings us to the thought that the spirit and the flesh are in opposition one to another. This antithesis we find everywhere in the Lord's Word. Jesus calls our attention to it. "Watch and pray lest ye enter into temptation." "The spirit indeed is willing but the flesh is weak." In some of the passages we quoted from the 8th chapter of Romans, we find the same thought. "For to be carnally minded is death; but to be spiritually minded is life and peace." Then in the verse following our text, Gal. 5:17, we read: "For the flesh lusteth against the spirit and the spirit against the flesh: and these are contrary the one to the other: so that we cannot do the things that we would." This lifelong opposition, this lifelong contradiction, we will find, dear brethren, if we have been begotten of the spirit; it will never be over until we succeed in killing actually the old man that reckonedly we laid down in death at consecration. "Ne'er think the victory won" until finally the flesh has been entirely used up in death.

From the fact of this opposition between the two we want to draw the lesson that mainly concerns us in our theme tonight, -- "Walking in the spirit, the preventive of walking according to the flesh." Or, to use the language of the text, "Walking according to the spirit, the preventive of fulfilling the lusts of the flesh." How is the flesh developed? We pointed that out a little while ago, but we want to speak a little more particularly now. The fleshly mind lays hold on certain principles, certain thoughts, certain ambitions, and the will laying hold on these seeks to bring in conformity with these the tendency, or bent, of the person. The man who has ambition for gold has his ambition mapped out before he works his plan in accordance therewith, holds these thoughts by will-power on his mind, and forces these to charge his character, so that they become the dominating matter in his life. Then by continual practice, in acts, of these principles that he has made, he more and more acquires a habit or disposition according to which he acts out these things. And then as he lays hold upon whatever instrumentalities that might come within the scope of his activity, he seeks more and more to attain these ends.

With the spirit, in the opposite direction, the same method is used. The new will -- using the word in its primary sense as that which is begotten of God in us when we consecrate ourselves and He accepts the consecration -- lays hold on the knowledge that God has graciously given us, which causes that knowledge to flow over into the affections, and it hold the affections into subjection to that knowledge. And in all the activities of life, it seeks to make these affections conform to that knowledge, and in that way makes these affections partake of the same disposition that is in the new will.

Now, dear brethren, if we can only realize that thought, making it a matter not only of the intellect, but a matter of daily activity, we have the whole battle before us, and we are far, far on the way to victory. But based upon that principle (that this will that God begets in us, the spirit laying hold on the Word of God that is in the mind, and that the will brings into the heart, charging the affections with its own nature, with the nature and disposition that is in that word) is another principle, and that principle is God Himself, whom we appropriate, through Christ, for all the strength that we need. 1 Cor. 1:30 is one of the most important passages in the Bible. Very few passages give us more than that one. "But of Him are ye in Christ Jesus, who of God is made

unto us wisdom, and righteousness, and sanctification, and redemption." When we on that basis of daily appropriation of our Lord Jesus Christ seize by this new will the thoughts that we have received from our Heavenly Father's Word, and fix these on the affections of our heart, holding them there in spite of everything by conscious operation -- by these two things (1) the trust in Christ, the appropriation of Christ, and (2) by this conscious laying hold of these thoughts in the mind which we receive from the Lord's Word, putting them upon the affections, charging the affections with these, -- by these two things the whole operation of sanctification is accomplished.

Now, brethren, the thought of the text is very simple. It is, that if we are fully occupied with leaning upon the Lord Jesus Christ for all the strength we need, and then from such an appropriation of Christ, who is made unto us wisdom, and righteousness and sanctification and redemption let this new will exert itself consciously, as we have indicated, more and more the flesh is subdued until finally it will be entirely dead. The new will will not only be supreme, but it will be absolute. And this is what we are seeking; this is what we must have if we would be overcomers; and, dear friends, within less than seven years, we must do that, if we want to be in the "little flock." It will make some of us hurry, brethren.

This brings the opposition. Those who are fully occupied with that, those who give their whole heart to walking in the spirit of these things, do not, cannot, fulfill the lusts of the flesh; it is impossible. Why? Because the spirit walks in one direction and the flesh walks in another direction, and you cannot walk in two directions at the same time. It is very simple. The philosophy of God's Word is simple when once we see it eye to eye. We cannot walk in two directions at once, and that is why the Apostle says in our text, to walk in the spirit, and does not add, "Do not fulfill the lusts of the flesh." But he says something will follow of itself, something is self-evident, namely, that "Ye shall not fulfill the lusts of the flesh."

### **Conscious Exertion of the New Will.**

We want again to refer to the importance of having this thought consciously in our minds. We cannot emphasize that too much. The conscious exertion of this new will, after it lays hold on Christ for all the strength, and upon the thoughts that God has given us in our mind, bringing these into our heart, and subduing the heart and the mind, to the influence of those words brought there by the will, -- that, done consciously, is the most important thought we can give you tonight. The other is the drifting life, and the drifting life does not make us overcomers. This life of conscious exertion of the new will within the sphere of spiritual things, in harmony with the Lord's Word, is what makes a character that is fitted to be a joint heir with Christ, a King and a priest in the next age, and inheritor of the divine nature and it is only those whose love for righteousness and for God is so strong that they are willing to let everything else remain in the rear and keep that conscious exertion of the new will in the foreground in their lives who will overcome.

### **As a Man Thinks in His Heart So He Is.**

Dear brethren, we want to show you from the Lord's Words that not only is this principle taught in our text, but it is likewise taught elsewhere in the Word of God. We are not giving human

philosophy. We have no trust in human philosophy. If human thoughts are in harmony with the thoughts of the Word, we are glad; but our confidence is not in the arm of flesh; our confidence is in God. Prov. 23:7: "As he thinketh in his heart, so is he." As he thinks in his heart, not simply in his mind, so is he. And as he is constantly, consciously thinking, so is he; his character is as his thoughts are. And as thoughts are taken into the heart (not simply in the mind, but taken into the heart) from the love of them, the new creature laying hold on these thoughts in the Lord's Word, so is he; the disposition becomes like that of the new will, and thus overcoming is made possible.

Proverbs 4:23, "Keep thy heart with all diligence; for out of it are the issues of life." Here is the consciousness; the constant keeping in mind by exertion of the will, the new will, along the lines of the Lord's Word brought out, -- keep thy heart with all diligence; for out of it are the issues of life -- character is developed by it; therefore we must watch what goes into and what goes out of it.

The same thought is given with larger emphasis in the New Testament. Jesus frequently expressed it. Matt. 12:34, 35: "Out of the abundance of the heart the mouth speaketh. A good man out of the good treasure of the heart bringeth forth good things: and an evil man out of the evil treasure, bringeth forth evil things." Matt. 15:18: "But those things which proceed out of the mouth come forth from the heart; and they defile the man." He is speaking here of the evil heart. Jesus gives us the same thought in John 15:3 and 11: "Now ye are clean through the word, which I have spoken unto you." As we allow that Word to rest in our minds, and then by constantly exerted will-power, lay hold on it, and charge our affections with its disposition, thus are we clean, thus we walk in the spirit, and we thus do not fulfill the lusts of the flesh. In the 11th verse, he says: "These things have I spoken unto you, that my joy might remain in you, and that your joy might be full." "These things" -- He had been speaking a great many things of the Lord's Word to them. "That your joy might be full." Joy is one of the fruits of the Spirit, and one of the things that goes with walking in the Spirit. John 17:17: "Sanctify them through thy truth, thy Word is truth." John 20:21: "But these things are written, that ye might believe that Jesus is the Christ, the Son of God; and believing, ye might have life through His name." These things are written" -- the thoughts of the Lord's Word, taken into the mind. Why? "That ye might believe." They work faith.

Acts 11:13, 14 -- "Send men to Joppa and call for Simon whose surname is Peter; who shall tell thee words (thoughts, which if you keep in your mind, lay hold upon by will-power, and thereby charge your affections) whereby thou and all thy house shall be saved." Acts 20:32 -- "I commend you to God, and to the Word of His grace, which is able to build you up and to give you an inheritance among all them which are sanctified." The Word builds up; it develops the character; -- the Word laid hold of consciously by the will, charging the affections, until they have the same disposition as the new will that God begets in us has.

Romans 1:16 -- "For I am not ashamed of the Gospel of Christ: for it is the power of God unto salvation to every one that believeth; to the Jew first, and also to the Greek." Peter corroborates this. 1 Pet. 1:5 -- "Who are kept by the power of God through faith unto salvation, ready to be revealed in the last time." Note that we are kept by the power of God, which, he says, is the Gospel. God has planted the thoughts, and we take these thoughts into our hearts and minds. Ye

are kept by the power of God through faith. That rests upon God from whom the power comes; it appropriates God as its own; it appropriates Him that has been made unto us wisdom, righteousness, sanctification and redemption.

Romans 10:17: "So then faith cometh by hearing, and hearing by the Word of God." -- Another one of the qualities or fruits of the spirit wrought by the Word of God. 2 Cor. 3:18 is one of the most comprehensive passages in the whole Bible. "We all with unveiled face (the eyes of our understanding opened) beholding (the will keeping the thoughts in the heart) as in a mirror (the divine plan) the glory of the Lord (His wisdom, justice, love and power in their blending) are changed (by looking) into the same image from glory to glory, even as by the spirit of the Lord." This new heart and mind makes the change by the Word that it has, through which it is charged and by which it charges the affections.

Philippians 4:8: "Finally, brethren, whatsoever things are true, whatsoever things are honest, whatsoever things are just, whatsoever things are pure, whatsoever things are lovely, whatsoever things are of good report; if there be any virtue, and if there be any praise" -- now what? Notice what he says; not work, not act, not talk. O, brethren, how simple the divine philosophy is! "Think on these things." And that is the final thing. Let us see to it that it is done. Think, consciously exerting the will, the new creature constantly laying hold on these things, the true, the just, the honest, the pure, the reputable, the lovely, the virtuous and the praiseworthy. Why did the Apostle manifest such solicitude for our thinking on these things? He knew the transforming power of God's Word, when the new creature lays hold on it, charging the affections with it, and therefore he says, "Think on these things."

Again, 2 Tim. 3:15-17: "From a child thou hast known the Holy Scriptures, which are able to make thee wise unto salvation, through faith which is in Christ Jesus. All Scripture is given by inspiration of God, and is profitable for doctrine, for reproof, for correction, for instruction in righteousness." Why? It is profitable for authority, what we ought to believe; for reproof, what we ought not to believe; for correction, what we ought not to do; for instruction in righteousness, what we ought to do. Why? Why these thoughts of the Lord's Word? "That the man of God may be perfect, thoroughly furnished unto all good works." Now this conscious exerting of the will on these thoughts makes action, and these actions repeated and repeated develop habits, and these habits strengthen and crystalize in the character; as we have all read, "Sow a thought and reap a word; sow a word and reap an act; sow an act and reap a habit; sow a habit and reap a character; sow a character and reap a destiny." And oh, let us sow a character of God's spirit and reap a divine destiny.

Let us notice how God's Word tells us that thoughts have some effect on the character. We will quote only two or three passages here. Romans 12:19-21: "Dearly beloved, avenge not yourselves, but rather give place unto wrath; for it is written, vengeance is mine, I will repay saith the Lord. Therefore, if thine enemy hunger, feed him; if he thirst, give him drink; for in so doing, thou shalt heap coals of fire on his head." Now notice this: "Be not overcome of evil." How do we overcome the flesh? "Be not overcome of evil, but overcome evil with good" -- not with flesh. We do not overcome by fighting the flesh. We overcome by developing the spirit, dear brethren, -- the spirit in the second sense in which we use that word. The spirit in the first sense, the new will given to us in the begettal, overcomes by charging the affections with God-



likeness. "Overcome evil with good." Not the evil in the other, but the evil in ourselves, the resentment and the revenge that would arise in our own hearts against evil treatment from others -- these thoughts being kept on the affections by this consciously exerted will-power on the part of the new creature, constantly and habitually done, and the resting of it all upon Christ, who is made unto us of God, wisdom and righteousness and sanctification and redemption.

We want to call attention now to another fact, and that is that everybody does not do that. We want to say that all new creatures do not do that. We want to point out a mistake that in the experiences of most of the children of God has retarded their growth. Most of us have been making that mistake. Probably all of us did for a while, some getting over it sooner and others later. We have been making the mistake of fighting the flesh and not developing the spirit, and on that account we became discouraged; we made but little progress, and noting the progress we did make, compared with what we ought to have made, and counting the time that we have had in the making of that progress, and counting that yet remaining, many of us have thought, "Well, it is impossible for me to be a more than overcomer through Him that loved us." Dear brethren, we believe that it is impossible for a person to become more than a conqueror who simply fights the flesh. The divine plan marks out an altogether different program. Another arrangement is ours: -- not fighting the flesh, not contending with it, not giving it the attention; but let us attend to the spirit, and let it consciously exert itself with the knowledge that is received from the Lord's Word upon the affections, charging these by habitual action, and the flesh will by it be taken care of -- that is, be killed, which is the care the new creature gives the flesh. Have we been making this mistake? We believe all have for a while. Are we still making it? To those who have not found this thought, from the Lord's Word, we would most earnestly suggest the ceasing of that fighting of the flesh, the fighting of the faults primarily and directly, and would suggest a flank movement, an attack on the flesh from the rear that will completely rout it. As we cannot walk in two directions at one time, as we cannot put two things into the same space at one and the same time, neither can we walk according to the spirit and according to the flesh at the same time. And if we keep that in mind we will be prevented from a large amount of hard fighting of the flesh, simply through a large amount of hard exertion of the new creature along the lines indicated.

Now, we want to make our application. We have explained the text, and shown the principle contained in it to be a principle throughout the Lord's Word. It is the one that we must all lay hold on, if we would be more than conquerors.

### **Five Steps.**

We called attention a little while ago to the five steps that must be taken in the walking in the spirit. They are:

- (1) Self-denial.
- (2) The learning of the Lord's Word.
- (3) Practicing the Lord's Word.
- (4) Spreading the Lord's Word.
- (5) Suffering for the Lord's Word.

Unless we accomplish those five steps we cannot be joint-heirs of Christ. If we succeed in four,

but fail in the other, we fail of attaining our full ambition; we fail of the "Little Flock." How, then, should we proceed?

Let us take up the first step. We noticed before that we are in a fight; that the flesh will always contend against the spirit, and that the spirit will always contend against the flesh. "The flesh lusteth against the spirit and the spirit against the flesh: and these are contrary the one to the other; so that ye cannot do the things that ye would." (Gal. 5:17.) And the greatest contention the flesh gives is along the line of resistance to self-denial. If the flesh can only here gain the upper hand, it does not care so much about the rest. The heart of the fight, then, is here. How may we overcome the flesh? We are called upon to deny ourselves in the interest of the Lord's Word. We are not talking about a sinful disposition, but we are talking simply about the natural disposition. The natural disposition has been to seek our own ends and objects. That course of conduct developed a habit in us that more and more developed the character in us. Now we have to resist and fight that will unto the end. It exerts itself in connection with self-denial. It throws on the heart and mind a large number of thoughts of ease, comfort, and of pleasure, of home, of friends, of country, of ambitions and of prospects. It pleads, then, when these are not given sway, to have at least a little consideration, a little help, a pace not set so rapidly; and a little breathing space, it will finally say, when it sees the new creature and its determination to choke it to death. How are we to proceed? We are to deafen our ears entirely to it. How can we do that? Why, by filling our minds so full of the other thoughts that there cannot be room for the thoughts of the flesh. You cannot think two kinds of thoughts at the same time. The secret is this: Learn to fill the heart with thoughts of self-denial, and the victory is won.

What are such thoughts? The Lord's Word gives us a great many of them. It holds up before us God's self-denying love. "God commended His love toward us, in that, while we were yet sinners, Christ died for us." What does that mean? The Father's love He commended to sinners, to enemies, in the giving of the only begotten, well-beloved, son unto death. The thought of Christ, stripping Himself of His former glory and becoming poor for our sakes, that we through His poverty might become rich, of His maintaining that poverty, of His actually accomplishing through three and one-half years of the most self-denying love ever exhibited in this world the fruits of self-denial, the usefulness of it, the indispensableness of it in the attainment of the Lord's character, the Lord's commendation of it, the desire to have His approval, the victory at the end, the crown of life that shall come to the faithful --- all of these thoughts must be held on the mind securely, not with a weak hold, not now a little while and then let go of in order to listen to the thoughts that would suggest the other course, but held upon the mind consciously; constantly, persistently, until finally victory is in the hands of the spirit. Thus we overcome self-indulgence; we have learned self-denial. Dear brethren, it is a lesson that takes time to learn, if we are to be fitted for joint-heirship with our blessed Lord and Master, Jesus Christ.

The next step is  
**The Learning of the Lord's Word.**

How may we learn to take that step? Meditating on the Lord's Word, contemplating its heights, its depths, its riches, its wealth and its favors. How may we learn that? Naturally a large number of earthly thoughts flow into our minds. If we are of a philosophical bent, they will be philosophical subjects; if we are of the student cast of mind, all kinds of thoughts along the lines

of abstract and concrete subjects on which we delight to reason will come to our minds; history, economics, and the little concerns of daily life; and these will be allowed to crowd everything else out. This is the tendency of the flesh. It gravitates toward its own. It minds the things of the flesh, as Paul tells us. How may we overcome that? Not by inclining that way, not by holding in that direction, not by giving it a little room. We may of course think along natural lines as far as these are necessary that we may be put in such a condition as best to fulfill our office as priests of God; but apart from that our minds are to be diverted to something else. The new creature lays hold on another line of thought. Concentration of thought comes here, and the Lord wants us to be as the godly man described in Psalms 1:2 -- "His delight is in the law of the Lord; and in His law does he meditate day and night." This is of supreme importance. The Lord's Word has a wide scope. In God's Word the treasures of wisdom are hid, and as they unfold to us in the light of the dawn of the millennium, how our hearts rejoice, and how, with joy unspeakable, we hail the bright and morning Star, as its rays shining on us, gives us a foretaste of what is to come! How is this step taken? The new will consciously exerted, fully aware that these other thoughts want to enter, fully aware that the old will is determined in the fight, will not give way to it, but persists in holding the mind down to the beautiful thoughts of the Lord's Word, the worlds, the ages, the planes of being, the pyramids, the time features -- all that is necessary in order that the man of God may be thoroughly furnished unto every good work. Mental wandering is so easy; all we need to do is to do nothing, and mental wandering sets in -- and not on the Lord's Word; we are leaky vessels, and therefore conscious exertion of the will, redeeming the moments, not the hours, not the days, but the moments, for they are become more precious than diamonds, as quickly they flee away, reducing the number yet before us. And only under such conditions, the will consciously exerted in holding upon the mind these thoughts, will it be able to take the further step, that of transferring the thoughts from the mind to the affections, and their doing the work of perfecting the character.

This brings us now to the next step,  
**Practicing the Lord's Word.**

We are to learn to walk that step, practicing the Lord's Word. what do we mean by that? Developing the Lord's spirit. We mean developing the spirit in the second sense in which we have used that word, and in which the Lord's Word uses it, the fruits of the spirit. Let us mention some of these: faith, hope, love, peace, joy, meekness, patience. The flesh has something against every one of these. The flesh has against faith, doubt; against hope, it has despair; against love, it has selfishness; against joy, it has sorrow; against peace, it has worry; against meekness, it has pride; against patience, it has impatience. The flesh naturally tends in these opposite directions. Now, how are we going to learn to overcome? Analyzing the situation, we realize that the flesh has gained its power in these vices, in these faults, because thoughts have been allowed to remain upon the heart, put there by the natural will which charged the heart, apart from heredity, with the nature of those faults. The thoughts of faults, therefore, kept by the natural will on the heart make these faults. And that is why, for instance, we have doubts. We have doubting thoughts, and these doubting thoughts modify other thoughts, and these in turn become charged with further doubts, and these charge others with further doubts, until finally the disposition becomes a doubting disposition. How may we overcome it? Do not fulfill the lusts of the flesh in this

doubting, but walk in the spirit. This will accomplish the end we are seeking. And how? Consciously exerted will-power takes the thoughts of faith from God's Word and forces these to remain upon the affections, upon the heart, and these charge the affections of the heart, and these in turn charge other thoughts and affections, and these still others, until by and by we are filled with faith, and being full of faith, there is no room for doubt. How have we accomplished the operation? Consciously exerting the will of the new creature to hold upon the affections of the heart the faith-making thoughts; and these faith-making thoughts are in the Word. "These things are written that ye might believe." They are in the Word. Let us allow them to rest on our minds. How many thoughts of faith are found there? Let us suppose our besetting fault were despair, despondency, and we want to develop, as new creatures, the opposite heart: how shall we proceed? Not by fighting from the front, as it were, the fault despondency, discouragement, despair, for we are not stronger than ourselves, and that is why this method is useless. It is the spirit that is stronger than the flesh. And the spirit consciously exerts itself in will-power to hold upon the heart and the mind the thoughts of the Lord's Word required for the development of the fruit in question. How so? We have become in this despairing, despondent condition because we have allowed these thoughts to rest on our minds; we have allowed Satan to put in our minds the thoughts of our failures, and mistakes, and imperfections, and have allowed him to so crowd out of our minds by these thoughts the opposite thoughts of the Lord's Word, that despondency charged our affections until despair had become fully fixed there. How may we overcome it? Walk in the spirit and do not fulfill the lusts of the flesh in this respect -- consciously exerting the will in laying hold on the thoughts that the Lord's Word contains, and thus these will charge the other thoughts, and these in turn will affect other thoughts, and these in turn will affect still other thoughts, until finally we shall become changed into the hopeful attitude of heart that Jesus had. And are there such hopeful thoughts in the Lord's Word? Oh, brother, it is full of hope. "That we through patience and comfort of the Scriptures might have hope." (Romans 15:4.) What are some of these hopes? That God is on our side, that Jesus' blood covers all our sins, that we are acceptable to the Father in the beloved, that the Father is disposing all things unto our good, making all things work together for good unto them that love God; that He is giving us such lessons, such experiences, such providences, as will fit us for the kingdom. Dear brethren, are these not hopeful thoughts, that we have on our side, that He wants us to overcome, that He is doing everything except forcing us to overcome? He wants the new will to do the forcing, and He gives the new will all the power through the Word that it needs to force the affections into a proper attitude.

Let us suppose our besetting fault were selfishness: walking in the spirit would require that we develop love in its place. How shall we proceed? It would be well for us to understand how this selfishness has been developed. It has been developed by thinking selfish thoughts. We have been occupied with our conveniences, and comforts, and hopes, and ambitions, and prospects, or those of our family or relatives; we have not been thinking of those who have not some immediate relation of interest to our well-being, but of ourselves. These thoughts resting upon the affections through the natural will charge the affections with their own character, and these affections in turn charge others, and these charge others, and these in turn charge still others, until one is wholly given over to selfishness. How may we overcome and prevent this? Walk in the spirit and ye shall not fulfill the lusts of the flesh. What would walking in the spirit in this respect mean? The will resolutely laying hold on thoughts that make for love. These thoughts are derived from the Lord's Word; they are in our minds, if we are the Lord's people and instructed

from the Lord's Word; and the will resolutely laying hold on these cause them to flow over into the affections, and these begin to charge the affections with their character, and these affections charge neighboring affections, and these in turn charge others, until finally the whole operation is accomplished, and love becomes ours; it is finally crystallized. When this consciously directed will-power is continued unto the end, it comes off a more than conqueror through Him who has loved us and bought us with His own precious blood.

Are there such thoughts in the Lord's Word? "Behold what manner of love the Father hath bestowed on us, that we should be called the sons of god." We love Him. Why? Because He first loved us, and love begets love. "Behold what manner of love the Father hath bestowed upon us." If we would let that thought rest on our affections, the love that God has shown us, it would surely charge our affections with the same character. And then the love of Jesus, the needs of others, and of our help, the needs of the brethren, the greatness of our God's character, calling out love -- we find a variety of thoughts that suggest and draw out love from the Lord's Word, and these, consciously kept on the affections by the new creature more and more spiritualize these affections so that they become of the spirit in us.

Let us suppose that sorrow is our besetting fault. How may we overcome that? We ought to look at how it is developed. We have been allowing saddening thoughts to rest on our hearts and minds. The old will delights in these under certain circumstances, so that it has been said that some people are not happy unless they are sad. We have allowed that sadness in some cases to rest in our minds, and that sadness has charged other feelings with its character, and those have charged others, and so the charging work has gone on until finally sadness fills the heart. How may we overcome it? Do not fulfill the lusts of the flesh? No, walk in the spirit and then the other will of itself, failing of exercise, cease by and by. As the new creature takes its power unto itself through the Word and charges the affections with the character of that word on this subject, the affections become full of joy. And are there not joy giving thoughts in the Word? Oh, what thoughts are like God's thoughts for joy! The thought of the fatherhood of God and of our sonship, and of Jesus our Elder Brother, of our Savior made unto us, by God, wisdom, righteousness, sanctification and redemption; of our justification by faith, so that our sins cannot condemn us in the sight of God as long as we trust under the precious robe, of the Father's love shown to us in inviting us to the high calling, begetting us of the spirit, and in making everything work out for our good, of the crown of life, the hope of immortality. Brethren, if any people in the world ought to be joyful, it is the Lord's people. "Blessed are the people that know the joyful sound. They shall walk in the light of thy counsel."

Let us take peace, comfort. Peace has its opposite in worry. Worry is developed by permitting worrisome thoughts to rest upon the mind, and the natural will laying hold on these brings the natural heart more and more into conformity to these worrisome thoughts. This worry should not be antagonized directly, but indirectly, through the cultivation of its opposite -- peace. And as worry is caused by worrisome thoughts, so peace is caused by the new will laying hold on the thoughts of peace that lie in the mind, which have been received from God's Word, applying them to the affections and forcing the affections to be charged with the disposition of the thoughts that the will puts on the heart.

The same general principle we find with reference to patience and impatience. We develop

impatience simply by permitting impatient thoughts to rest upon the heart, the natural will cultivating these. They may be overcome, not by direct antagonism, but by indirect antagonism, through walking in the spirit. This is accomplished by the new will laying hold on the thoughts that work for patience in the Lord's Word and which rest in the mind, charging therewith the affections, until they have received the disposition of these patient thoughts. Manifold, indeed, are the thoughts of patience in the Lord's Word. God's marvelous patience, the patience of Jesus, that of the consecrated ones, the need of patience for our development, both for usefulness now and for usefulness in the age to come, will prove helpful thoughts for the new will to lay hold upon in subjecting the natural heart to its way.

Let us have a word on meekness. The opposite of meekness is pride; and the old man is full of pride. There is no sin to which the most of us are prone more than to the sin of pride. More have fallen from Present Truth through pride than through anything else. How may we overcome it? How has pride been developed? Proud thoughts have been allowed to have a congenial resting place in our minds and hearts, and these have gradually charged us with their nature until we are full-fledged in pride. How may we overcome it? We had developed it by thinking of our advantages, of our abilities, mental, physical, and moral, generally contrasting them with the inferiorities we see in others, until finally we are lifted up with pride, ready to burst, as the frog in the parable. How may we overcome it? Brethren, if our fault is pride, walking in the spirit would suggest to us that we fill our hearts with the thoughts of our mistakes, and our sins, and our faults, and our failings, and our littleness, of the many things that others have that are far beyond what we have. Brethren, when we think of the great God of the universe, who had deigned to look on us, how can we think highly of ourselves? Let us allow these thoughts to rest on the mind, the new will consciously exerting itself, taking these thoughts that the Lord's Word gives us, that we have in the mind, putting them upon the affections, charging the affections with these, holding them there unremittingly until that which we seek is attained. This is the practice of the Lord's Word, and thus the third step is learned.

This brings us to the fourth step,  
**Spreading the Lord's Word.**

The fourth step we learned in walking in the spirit is that of spreading the Lord's Word. In a variety of ways we are permitted to do this: By speaking words from mouth to mouth, by distributing the literature as colporteurs, sharpshooters and volunteers, by arranging for meetings in which the Word may be heard, by taking part in these meetings, by encouraging others to attend and take part, by inviting people to attend, by making arrangements for meetings, both for the brethren and for the public when Pilgrims come, by letter writing -- specially to the isolated and the tempted and the weak, and by using of our means to support the general agency of the work. But the flesh would have its activity along altogether different lines and would impose all kinds of obstacles in the way of such a use of our opportunities for the spreading of the Lord's Word. It will, therefore, be necessary for us to lay hold on thoughts that make for zeal in the spread of the truth. Loving zeal, therefore, is the leading qualification necessary in connection with walking in the spirit, in the spreading of the Lord's Word; and as the flesh would seek to suppress zeal, the new creature lays hold on the thoughts of zeal in the Lord Word, that have been received in the mind, charging the affections with these thoughts until they are full of love and zeal for the spread of our Heavenly Father's truth.

Many indeed are these zeal-causing thoughts. God's zeal in manifesting His love for us; Christ's zeal in connection with the work, the Apostles' zeal shining out in their activity, the privilege of sharing in the work, both in its joys and in its sorrows, laid hold on by the will and applied to our hearts, will more and more charge them with loving zeal, and thus continue in the spread of the Lord's Word in spite of opposition and of every inducement of pleasure, of convenience and of profit.

This brings us to the fifth step,  
**Suffering for the Lord's Word.**

The fifth step that must be learned by those who walk in the spirit if they would be overcomers, is that of suffering for the truth. This suffering will manifest itself in physical exhaustion, mental sorrow, and physical violence; and to stay our hearts amid these varied sufferings, it will be necessary that the new creature lay hold on thoughts fitting for the circumstances in which we are, applying these to the heart and bringing the heart into conformity with its directions, as it charges the heart with the spirit that is in the Word. Physical exhaustion will especially tax us along the lines of strength, of will, and of perseverance. At first, the flesh does not interpose so many obstacles to the work of the Lord, but by and by when physical exhaustion sets in, the flesh brings up all kinds of obstacles. And here strength of purpose, steadfastness of devotion, and an appreciation of the value in God's sight of such suffering and physical exhaustion as a part of our sacrifice, are necessary to be kept on the heart by the new will, so that more and more the heart be charged with these thoughts and thus respond to them. God's perseverance in seeking the "little flock," and Jesus' perseverance in developing the "little flock" during over eighteen hundred years, are striking examples of strength of purpose for the accomplishment of the end desired. And so, holding these on our minds and charging thereby our hearts, more and more the new will gives such strength of purpose as enables us to stand physical exhaustion in the interest of our Father's cause, and thus we walk in the spirit in connection with enduring physical exhaustion.

Physical violence may be experienced in a variety of ways. In the things in connection with our daily living, as well as in our own person; boycotting and social ostracism, are often things to be endured by the Lord's people in order that they be true to His cause. And in many cases it has gone even to laying violent hands on them, to the taking of their lives. Under this, the flesh cringes; it seeks deliverance, it contrives in every way to work out its natural inclinations for deliverance, it seeks to put on the heart the thoughts that would oppose such a course. What should we do in order to walk in the spirit here? Not simply to fight the flesh because of physical losses, whether in strength or in health, or in pain, but by the new creature realizing the importance of long-suffering -- enduring long. These thoughts that we have in our mind, derived from the Lord's Word, the new creature applies to the heart, that it might learn to suffer long and be kind. And then these gradually charge the heart into conformity with their nature, and thus long-suffering is learned.

God's long suffering in permitting His name to be traduced, and His character impugned and blasphemed, for nearly six thousand years is the most striking illustration of long-suffering. If we permit this thought alone to rest on our minds, charging therewith our hearts through the new

creature, it will surely enable us to develop like long-suffering.

Forgiveness is also an element that will be called into play in this connection. The wrongs that we are required to endure on account of our loyalty to the Lord's cause are of such a kind as calls for the exercise of the spirit of forgiveness; but probably the spirit finds nothing so hard to exercise as true, loyal, loving forgiveness in the name of the Lord; for herein lies love of enemies, which is the perfection of love. The flesh would be stirred up to resentments; it allows hateful thoughts to rest upon the heart and thus bitterness is more and more increased and love for enemies is made impossible. How may we overcome this corrupt tendency? We reply, by permitting the forgiving thoughts of the Lord's Word that we have in our minds to rest upon our hearts through consciously exerted will-power on the part of the new creature, charging the affections with these unremittingly until the heart is made, in forgiveness, like that of God. Such thoughts as will produce this effect are as follows: Our enemies are our best friends, because they alone give us the opportunity to develop love for enemies, without which we could not be overcomers; therefore our enemies are our best friends. They are helping us to complete our sacrifice, and therefore carrying out God's plan. They unconsciously are proving a blessing to us. They are likewise enabling us to develop other traits of character needful for our future ministry. They are blinded by the god of this world and do not understand what they are doing, for if they would understand the true situation, their conduct would be far different. And this thought resting on the heart will enable us to overlook their conduct. Then, too, the injury they do their own character in their mistreating us is so much greater than the injury they do to us that pity for the awful consequences to themselves of their misdeeds should fill our hearts, rather than resentment for the wrongs they do us. When the new will lays hold on these thoughts, in connection with our contract with our enemies, causing them to charge the heart, the heart by and by takes on the spirit of these thoughts and forgiveness, which enables us to suffer for the truth, will be developed in us.

So we have seen the five steps whereby the spirit walks.

We want to close now with the thought which we began. In about eight years' time the eternal destiny of almost everyone in this room (for we believe that almost everyone in this room is spirit-begotten) will be fixed. Dear brethren, our eternal destiny will be fixed by what we do with respect to the thought contained in this text. For, if we walk in the spirit, our eternal destiny will be fixed on the divine plane; it will be fixed with Christ, and with God forever -- with Christ as agents of God in connection with creative work, first with the race here, and then in God's boundless universe elsewhere in accord with the plan -- His hidden thoughts, of which we know practically nothing now; forever and ever with these will we be occupied. Our eternal destiny, being now new creatures, will be fixed in less than seven years, if we attain the divine nature, and in about eight if we are in the spirit class. But if we do fulfill the lusts of the flesh, and give ourselves over to that character, there remaineth a fearful looking for judgment and fiery indignation, which shall devour the adversaries. We are persuaded better things of you brethren; of things of God, and of Christ, and of the spirit. "Walk in the spirit and ye shall not fulfill the lusts of the flesh." Amen.



## MONDAY EVENING

At 8 p.m., while Brother Johnson was delivering his discourse in the Auditorium, as per the regular program, there was an overflow meeting in the Reception Room on the first floor, for the benefit of two or three hundred who could not get in to hear Brother Johnson. This overflow meeting was conducted by Brother Van Amburgh, as a testimony meeting. He suggested that inasmuch as we had been feasting greatly and our hearts were so full, it would be good to make the meeting one of testimony, and that each one preface their testimony with a text of Scripture, in order that the texts being brought to our minds might refresh our hearts. This was accordingly done, and a blessed hour of fellowship was there enjoyed. Lack of space, however, will prevent publishing these testimonies. We can only suggest that you attend the next convention and hear them for yourself.

## TUESDAY, SEPTEMBER 3.

### 5:30 A.M. - Sunrise Prayer and Praise Meeting.



About five o'clock, while it was yet dark (like in the days of old, the women went while it was yet dark to the tomb where our Savior had been buried) the friends began to wend their way to the spot where, the day before, 241 symbolically buried "the old man." By 5:30 over a thousand were assembled to unite in prayer and praise to our Heavenly Father for all His goodness and mercy. Soon Brother Russell appeared and took charge of this unique service, greeting us with the salutation, "Good morning all, dear friends." To this was the response, "Good morning," from a thousand voices.

He then suggested that while waiting for the others to gather, we sing No. 152, "A Thousand Years." This was followed by prayer by Brother Van Amburgh.

Next was sung No. 89, "The Song of Moses and the Lamb."

Brother Russell: I was thinking, dear friends, as we gather here this morning, of the words of the Apostle, "Now it is high time that we wake out of the darkness," and then he proceeded to say that those that sleep, sleep in the night, but we are of the day. We recognize that the Apostle did not have reference to the literal day, except as it might symbolize the great day. Looking back, he referred to the past as being a night, and hence it is far spent and the day is at hand. So, when we compare this morning, the whole experience from the fall to the present time, with the morning of the new dispensation representing that great day, then we can easily see that the night is far spent; because four of these days and a little more were in the past and less than two in the future, and he could well say, it is far spent.

And what would the Apostle say, if he were here at the present time? We can suppose that he would be telling us something about the morning that is already dawning. We have heard the

glad strain from God's Word that the night has passed, that the morning has come, and we are in the very dawning of the morning. We call it the Millennial Age. I am sure those that have had experience in life will realize that the night of sin and darkness has been a long night, and we are getting anxious for the glorious dawn of the day that our Father has spoken of in His Word, and which He calls, "The day of Christ." If we knew nothing of what the nature or character of the Millennial Age is, the very fact that the Lord called it "The day of Christ" is sufficient. It is the day of the Anointed One, the day in which He will complete the work He came to accomplish. What a great thought it brings to our hearts, from His Word, that the morning is at hand! I trust that you and I, this morning, realize we have fled from darkness into the glorious light of the divine word and plan. The more we are seeking to have our hearts in accord with His Word, the more we will feel inspired to press on for the things before us. The poor world have very little that they can see before them; nearly all that is precious to them is in the past, and they can see only disappointment before them.

Another Scripture about the morning, you remember in the 2nd verse of the 46th Psalm: "Therefore will we not fear, though the earth be removed, and though the mountains be carried into the midst of the sea," etc. How strange we should not fear if society be convulsed; the shaking time for the whole world, social, financial and ecclesiastical, when all such ruling power that can be shaken will be shaken. And yet, we are not fearing, but we are rejoicing, leaving the world for a little while, and in our daily lives seeking more and more to lay all on the altar. What is it that so fills our hearts? The world has rather a feeling of timidity. It is a blessing they cannot see the troublesome time as we see it. But, blessed are your eyes and your ears -- it is because we know what is on the other side, beyond the dark cloud. A morning cometh and a night also. The night of trouble between the glorious morning is a time the world would fear if they knew about it. But we shall not fear, because we have made the Lord our refuge and habitation, and He has promised that all things shall work together for good to those that fear (reverence) Him. We have laid ourselves at His feet to have such experiences as divine providence may see best for us -- the things that would best prepare us for the glorious morning.

Then in that same Psalm, after the expression that we will not fear, though the earth be removed and the mountains be carried into the sea, the Psalmist is prophetically saying that there is a city, a government, a kingdom, that is now in disrepute with the world -- the Lord's Church, which He is gathering out, a little flock -- the gates of which shall be praise and salvation, the New Jerusalem, and the rivers of salvation make her glorious; she shall not be moved. Oh, no. Everything else may go down, but those that have the hope of the Lord, nothing can move them. Why? Because the Lord, the Most High, is their refuge and habitation.

Some one down in Kentucky had written a couple of letters that he would blow up the Bible House that was sending out those tracts and books, and a brother who happened to be in Allegheny said, if that message could get out everywhere and we knew exactly when he would do it, wouldn't we pack the Bible House full? It is very hard to discourage that kind of people.

We have an anchor, both sure and steadfast, reaching in beyond the veil, reaching clear back to Abraham's time to the Oath-bound Covenant of God, and further back to Adam, and through God's promise that the seed of the woman should bruise the serpent's head. That is the faith that brought us here. It had been lost for centuries in the rubbish, but now our eyes are open and the

shadows are passing away.

In the 45th Psalm, after telling about the Bride and how she should not be hurt, we read that the Lord shall help her and that right early. That is as it reads in our common version. A literal translation reads, "The Lord will help her right early in the morning." We are right here, early in this morning, the Millennial Age; the morning is already dawning. You do not see any sun this morning, neither is the sun of the Millennial morning visible. The sun of righteousness shall arise, but not yet. Before that, all the members of the Body of Christ must be gathered; all the true wheat must be gathered.

In Matthew the 13th chapter, after speaking of this whole matter, and representing the whole Gospel Age as the time when the wheat and the tares were sown, you remember our Lord said, after telling about the gathering of the wheat, "Then shall the righteous shine forth as the sun." Why not now? Because all the wheat has not yet been gathered into the garner. Then shall the righteous shine forth, then shall the morning of the Millennial Age be manifested. Now the world is asleep. Some of us have heard the glad message and we are glad to praise Him and to say that the morning is here, not only for ourselves but for the whole world -- that is glorious. Leaving out the thought of torment; suppose that all the rest were merely to be destroyed -- how much better the glorious hope that, very soon the knowledge of the Lord shall flood the earth and the sleeping ones shall awake and all be invited to breakfast. This will be a grand feast in the morning. He is going to gather all the people and spread a feast, a blessed feast. Singularly, in the original, it is not a supper, but a morning meal.

So, dear brothers and sisters, I hope your hearts are as glad as you are singing about the morning, and praising God, and I hope it makes your faces brighter day by day. As I see your faces from time to time, I can see that they are growing brighter. Wherever the life of the Lord is, it is sure to be manifested. I like to see those whose faces are happy. I would not say that those who have long faces have nothing that would cause them joy, but those that have their faces with God's spirit, which is shining out from their faces more and more, and through their lives more and more shining forth the praises of the Lord in calling us forth out of darkness into His marvelous light.

Six more hymns were then sung, and between each hymn a prayer was offered.

Brother Russell then said: Now, dear friends, the hour has about expired and as our seats are not as comfortable as they might be (nearly all had been standing throughout the service) we will close by singing hymn No. 1:

Praise God, from whom all blessings flow;  
Praise Him, all creatures here below;  
Praise Him aloud with heart and voice,  
And always in His Son rejoice.

## 10:30 A.M. -- Question Meeting

*held in International Opera House.*

**QUESTION** -- Since the scapegoat was not accepted for sacrifice, and did not enter the Holy could it represent a spirit-begotten class?

**ANSWER.** -- The bullock did not go into the Holy or the Most Holy, nor did the Lord's goat; and similarly the scapegoat did not go into the Holy or the Most Holy. If the fact that the scapegoat did not go into the Holy and the Most Holy were to be considered a proof that the class represented by the scapegoat was not to be spirit-begotten, the same argument would hold against those who are of the Lord's goat class, and the same argument would hold against our Lord Himself, represented by the bullock. It was the blood that was to be taken in, and that was all. Those who are represented by the scapegoat are represented for the time being in the body of the High Priest, as for instance, Jesus the High Priest first of all, in His first offering of the blood of the bullock, as the High Priest represented himself in taking the blood in himself individually. You and I were not in that at all. He went into the Most Holy on our behalf, and made



Brother C. T. Russell.

reconciliation for our sins. Then he came out and offered the goat of the sin-offering, the Lord's goat, and took of the blood of it. Now then, he was representing in that goat, you see, the members of his body, and he went in with the blood of that goat. But the goat itself was represented in the priest. The bullock was represented in the priest and now similarly the goat is represented in the priest and he makes the offering there. The scapegoat class are for the time being represented in the body of the High Priest. That is to say, when they made their consecration, they were counted as members of the Body of Christ, for the time being and it was only after they failed to continue in His way, failed to go on and complete their sacrifice, that they were eliminated and no longer counted as members of the Body of Christ, but thereby becoming a secondary company, or a company not found worthy of places in the Body of Christ.

**QUESTION** -- And they that are Christ's have crucified the flesh and the affections thereof." Does this include unnecessary affections between consecrated brothers and sisters? Is this not part of our sacrifice?

**ANSWER.** -- In taking such a passage as this, we must be careful to take other passages of Scripture with it, so we may be sure we are within the proper limit. If one passage of Scripture could contain the whole message of God, we would not have the entire Bible. Therefore the importance of the matter, if we would understand the way of the Lord, and the will of the Lord in many things, that we should have a comprehensive view of all the Scriptures that might bear on the subject.

Now the apostle in his letter to the Corinthians lays down certain relations that should obtain between husbands and wives. He there specifies that the one should not defraud the other, and

then he gives an intimation of certain limitations both ways in respect to relationship between husband and wife in the Lord. But I think that it is a proper enough thought to say that while it does not signify the entire elimination of everything that might belong to the natural man and the natural woman, it would mean that, having crucified these, having given up the affections and the lusts of the flesh, they are seeking to live on a higher plane, and should spend their time and energy in that which would be most profitable to themselves and most to the glory of the Lord, and for the greatest good to others with whom they may have contact. Therefore, to have thus given up our affections and ourselves to the Lord, would mean that according to our limitations - and these are not the same with any two persons but each one according to the limitations of his own flesh -- each shall seek to bring himself into that degree of subjection so that the very thoughts of his mind may be in harmony with the Lord, as well as all the acts of life. It is a general principle. It is not a principle that you could apply to another brother or to another sister; they must apply that for themselves, and you must apply it to yourself; and let each to the best of his ability do what he believes will be to the glory of the Lord and for the good of himself and others. And this is the moderation of which the Scriptures speak.

**QUESTION** -- How may we distinguish the Elisha class from the Elijah class?

**ANSWER.** -- We have pointed out that Elijah was very distinctly a type of the overcoming Church. But as for Elisha we have no positive proof in the Scriptures that he was a type at all. Some might infer that he was a type, and others might infer that he was not, but since the matter is one of doubt, it behooves us not to fasten very much weight to it.

**QUESTION** -- Did Adam eat of the tree of life before eating of the tree of knowledge? If so, why did he not live forever?

**ANSWER.** -- I answer that the word "tree of life" is in the plural. All the trees of Eden were trees of life. They were all good for food, beautiful to look upon. They were trees, the eating of which would have maintained the life which God had given to Adam. They were not trees to give some kind of a charm to him, which would hinder him from ever dying. That is not the thought. They were trees of life in the sense that their fruit, partaken of, would have permitted our first parents if they continued to eat, to live, and would have supplied all of the wastes of their systems so that they would never have needed to die. They had been eating of these trees, so far as our understanding of the Scripture goes, for a little over a year before they were led into temptation by the Adversary and ate of the forbidden kind of trees. We understand this tree of the knowledge of good and evil was not one tree, but one kind of trees, and of that particular kind of trees, they were not to eat. And when God, therefore, would have them die, He drove them out of the garden, away from the trees of life, and into the unprepared earth, where they must till the ground and battle with the thorns and thistles, until they were to return to this earth from whence taken. The penalty was death and the intimation is that if the Lord had allowed them to remain in Eden, they would not have come into a dying condition, but would have remained in full vigor and strength of their human nature, notwithstanding their being sinners.

**QUESTION** -- Moses said, "And if not, blot me I pray thee out of thy book, which thou hast written." What book is it that Moses referred? Is it the one referred to in Revelation 3:5?

**ANSWER** -- I would say yes, the same book; evidently the book of God's remembrance, the book of life. God is represented as having one special book in which only the names of the Bride of Christ are written. We are not to understand that Heaven has a large bookkeeping department. That is not the thought. We are not told how He keeps the record. We do not suppose that it is kept with paper and ink but God has His own way of keeping in knowledge. The Lord knows them that are His, and they are in His book of remembrance, and that is all we need to know. What did Moses mean then, when he said, "If not, blot me, I pray thee out of thy book?" We understand Moses here as the mediator for Israel, and representative of Israel, was very patriotic. He had been appointed of God to represent that nation, and he was so fully imbued with patriotism that there was not a particle of selfishness on his own part. He did not want anything to interfere with the interests of Israel; and you remember God, in order to quiet him, said, "Now, Moses, you see this is a disobedient people and they are continually backsliding; let me alone that I may blot them out of existence, and I will take you and your family and make of you this great nation who will inherit all of these promises." And you remember Moses' prayer. It shows a very noble, high standard of patriotic feeling, and brotherly kindness that very few could appreciate. Moses was evidently a very noble character, and in that respect very worthy to be compared to our Lord Jesus Christ who took practically the same point of view, and as our representative risked the blotting out of His own life on our behalf.

**QUESTION** -- When is the world justified, at the beginning or at the end of the Millennium?

**ANSWER.** -- We answer that the world will be justified at the end of the Millennium. According to our understanding of the Scriptures, God's dealing with the world will not be the same as His dealing with the Church. Now, those who believe individually are reckoned as justified. Mark you, they are not justified, but reckoned as justified. The word justification means, to make right, and you know your body is not right and I know that my body is not right. Believing into the Lord Jesus Christ did not make the body right or set the organs in proper balance in your head, and did not grant you perfection of being at all. But when He comes to deal with the world, He will not so deal with them, the dealing with the world, as the Scriptures point out will be an actual justification, and instead of saying to the people, during the Millennium Age, now you are justified by faith, the message will be, You will now obey the law of this kingdom and if you are obedient you will make steps of progress back, back back to perfection, and when you get back at the farther end of the Millennium, you will be perfect and you will be just. They will not be justified, but they will be just. So God's proposition is for the world, that of bringing them back to actual perfection.

**QUESTION** -- Do we as individuals need Christ as our mediator before we become members of His Body?

**ANSWER.** -- I answer that if we had needed Christ as a Mediator, then God would have provided Him as a mediator and the fact that God did not provide Him as our mediator proves

that we do not need Him as such. The Scriptures never speak of a mediator except from the standpoint of a covenant. Whenever the Scriptures speak of a mediator, they always speak of it in connection with a covenant. As for instance, there was Moses, the mediator of the Law covenant and Christ the mediator of the new covenant. Abraham had no mediator. Why? The Apostle Paul explains that the first covenant was all of God, and God is One and where there is only one party there is no need of a mediator. What does He mean? Why, in the original covenant He made with Father Abraham there were no conditions specified at all. God says I will do thus and so. He does not say, I will do thus and so if you do so and so. Where it is merely an unconditional promise you do not need a mediator to carry out the plans and see that the two parties do right by each other. There are not two parties to it. God is the only party to that covenant. The Law covenant was made with the nation of Israel. Are we under the new covenant? No, because the new covenant has not come yet. The new covenant belongs to the future. How does it read; "After those days, I will make a new covenant with the house of Israel and with the house of Judah." Do you belong to the house of Israel or the house of Judah? No. Then the new covenant is not for you. If we are faithful we will be members of the mediator class of that new covenant. In other words, you and I are invited to become members of the mediator of the new Covenant. Christ is the mediator, but He is going to have a bride. Someone may say, Where do we come in? What covenant are we under? We are under the original covenant, which required no mediator. The church does not need a mediator. What does it need? Can they come direct to the Father? No Well, what do they need? They need just what the Scriptures tell us we have -- an advocate with the Father.

**QUESTION** -- Would it have been possible for any of the Ancient Worthies to have entered the second death?

**ANSWER.** -- I think not. In the time of the Ancient Worthies, God had made no offer at all to the world, and since they had not been released from the Adamic death, they could not have gotten into the second death. So, you see, not until Christ had died for Adam's sin, not until He had risen from the dead to be the judge of the quick and the dead, not until then would it be possible for anybody to get out of the Adamic death, and not until they got out of the Adamic death could they get into the second death.

**QUESTION** -- What would you advise in regard to the Pilgrim meetings? Would it be advisable to spend much money for advertising and for hall rent at this period of the harvest? Or would it be better to give the service more especially to the interests of those already in the faith? To what extent should the Pilgrim direct in this matter?

**ANSWER.** -- I would answer, dear friends, that my thought would be, answering the last question first, the Pilgrim should not attempt to direct in the matter at all. That is not the Pilgrim's business. We do most of the directing of the matter from the Watch Tower office. Pilgrims are supposed to be carrying out an outline of policy that is there laid down, and their acceptance on the Pilgrim staff implies that they are pleased to do so. It does not imply bondage, but implies the taking up the staff under those conditions, and implies they are pleased with and recognize the regulations there made as being under divine supervision. So I would say that the

Pilgrim would have nothing whatever to do with that matter. I am not aware that the Pilgrims do, but if any of them have done so, I suppose it was done inadvertently.

Now, as to what extent it is advisable to advertise, I would say this: We prefer to leave that in the hands of the friends themselves. Do as much advertising, or as little advertising for these pilgrim visits as you choose. Consider that a part of your stewardship; that is what you are to attend to. The Society attends to another part, that of sending the Pilgrim seeing to his expenses, etc., and the Pilgrim attends to another part. If each of these do their part, everything will be done right. So you see that leaves the responsibility with each party to do what he believes, according to his own judgment will be the Lord's will.

Our advice would be that there be not very many public meetings, because the special object of these visits of the Pilgrim is, to minister to the household of faith, and the public ministrations are not always the most beneficial thing for the household of faith itself. So we always urge that if there be both public and private meetings, the public meetings be not allowed to take all the time, but rather be at least half or more than half given to the matters that are of special interest to the household of faith.

**QUESTION** -- Those of the Great Company who died in the past ages, how will they come up out of great tribulation, as they died long before the tribulations came on?

**ANSWER.** -- I answer that, according to our understanding, there have been some of this class all the way down through the Gospel Age, yet the most of this class are living at the present time. There are reasons why, in the past there would not be nearly so many. For instance, when there was a sharp persecution against all who named the name of Christ, it was quite a test, and not so many were ready to make a full consecration of themselves. As a consequence those who did make a consecration were the class more earnest and willing to carry it out. But today, we are living in a time when everything is more favorable outwardly, and a good many people want to say they are Christians, whether they are or not. It is rather popular today. So some people have no doubt made a consecration under the present favorable conditions who would not have made it in the past. So a great many, we believe, are in this condition that they have made a consecration to the Lord, but because of the favorable conditions in another sense of the word, they are not living up to their consecration; they are not becoming overcomers; they are bound in Babylon. And so, this is the time when the Great Company ones are specially prominent. We are not competent to say who in all these various churches belong to this class, but we see that a large proportion of this class belongs in our day. Down through the age we would understand there were some who were unfaithful in a degree, in that they did not voluntarily and gladly and willingly lay themselves down after they had agreed to do so. We can see how the Lord might have allowed some of them to go through the persecutions, the thumb -screw and rack, and how they may have come through great tribulations then. I have no idea at all that all those people who suffered by being burned at the stake, etc., were saints. I am not judging them, but reading between the lines of history, I would infer that a good many of them were not saints in the highest sense of the word as we understand the Scriptures to imply.



**QUESTION** -- In a recent issue of a Tower, you say we are not quickened until we reach the mark and that some are never quickened. Do you mean that only those of the consecrated who do reach the mark are quickened to any degree or in any sense?

**ANSWER** -- I would not like to take the position that no quickening would commence until after the mark had been reached. The Apostle uses as an illustration the natural birth: "First, begetting, then quickening, then the birth." We are first begotten by the Word of Truth; then if we continue to be related to the Lord, the time of quickening, the energizing will come; and then if this energizing continues, and we continue to grow in grace and knowledge, we eventually in the first resurrection will be born. But I would not like to say that no one would manifest any signs of energy or quickening in the Lord's service until first he had reached the mark of perfect love, but I would think it fair to say that nobody would reach the mark of perfect love, without being quickened. That just as surely as he would get to the place where he loved the Lord with all his heart, and where he would love his neighbor, and his enemies even, he would be at the place where he would be sure to be quickened or energized in the service of the Lord and in the service of his neighbor. That is what we wished to say in the Tower.

**2:30 P.M. Praise Service.**  
**3:00 P.M. Discourse**  
**by Pilgrim Brother F. W. Williamson**  
*of Allegheny, Pa.*

Bro Williamson said, in substance, as follows:

Our text this afternoon, dear friends, will be found in Matt. 16-24: "Then said Jesus unto His disciples, If any man will come after Me, let him deny himself, and take up his cross, and follow Me." I am aware there are a great many people who think this text of Scripture ought to read

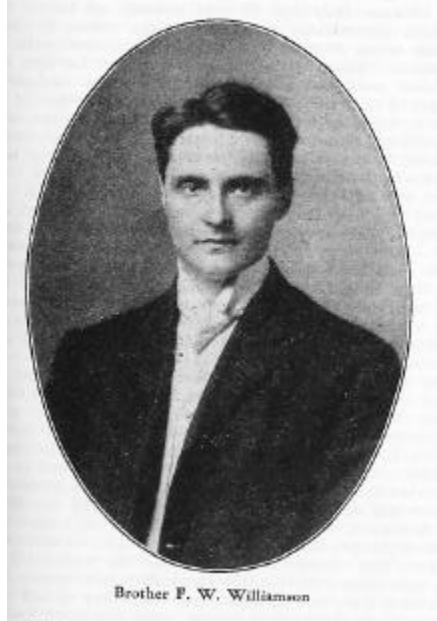

somewhat differently, and so they put this construction upon it, as though it read, "If any man will not come after Me, and will not take up his cross, and will not follow Me, he shall suffer eternal torment." That is the thought they have in their minds, even though they may not express it in so many words, the thought being that those who do not accept Jesus Christ at the present time, those who do not follow in His footsteps, endeavoring to do His will, are surely and certainly doomed to an eternity of terrible torture. But our Lord did not say anything of the kind. There is not an intimation in the whole text, or in all the surrounding texts, which justifies any such conclusion. He was not speaking anything about the punishment which should be upon those who do not do what is proper and right, according to God's purpose; He did not say anything about what would be in store in the future for those who were not endeavoring to do God's will. He was speaking, however, in regard to the blessing and favor which

would come to those who would do God's will, and that is the lesson which we want to bring to your attention this afternoon.

When our Lord Jesus gave these words, the whole of Judea, all of the Jews, all of Israel, were in expectation of the Lord; they were looking for the advent of a Messiah; and the disciples as much as all other Jews, and even more so, were looking for that glorious advent; were expecting the coming of the Kingdom; were looking for the establishment of righteousness in the world; were looking for the privilege of being associated with the seed of Abraham in bringing a blessing to all the families of the earth. And this is particularly intimated in this very same chapter where our Lord asked the disciples, "Whom say men that I am?" And they answered, "Some say Thou art John the Baptist, some say Thou art that prophet, some have other expressions to make," and our Lord Jesus put it to them expressly and asked what their opinion was when He said, "Whom say ye that I am?" And Simon Peter answered and said unto Him, Thou art the Christ, the Messiah, the anointed One, the promised Redeemer of Israel and the whole world, the seed of Abraham; Thou art the Christ, the Son of the living God. And our Lord acknowledged that Simon Peter had answered truly, saying, Blessed art thou, Simon, son of Jonas; flesh and blood hath not revealed it unto thee, but my Father which is in heaven. The disciples here acknowledged that He was the promised One, that He was the One that should establish the Kingdom of righteousness which God had intimated in His glorious promise to Abraham, and our Lord Jesus acknowledged that Simon Peter and the other disciples had the true conception of the whole matter.

Now, what was the attitude of the disciples in regard to that Kingdom? They desired that they might have a special place associated with the Lord in the work of bringing blessing to the world. They knew that God intended to bestow the richest blessing of His favor on the whole world of mankind according to the glorious promise which He had made, and their earnest desire was that they might share in that opportunity of bestowing the blessing. This was intimated when the two sons of Zebedee, James and John, came to our Lord with their mother, and asked Him if they might have the privilege of sitting with Him, the one on His right and the other on His left. And our Lord, instead of rebuking them and telling them that they asked Him something they should not ask, intimated to them that there might be such a possibility were they willing, were they able to endure the trials and difficulties which would be associated with the opportunity of reigning together with the Lord. And they answered, they were able, that they were willing; they rejoiced in the privilege that they might have of suffering together with the Lord, following in His footsteps, in an endeavor to do what was His perfect will; and though it was not the Lord's purpose, nor was it His privilege, to grant them their request, He intimated in His reply that the God of Heaven would grant the request as He saw good. That attitude of the two sons of Zebedee indicated the attitude of all the disciples; they wanted a special place in the Kingdom, they wanted to be associated with the Lord in the work of blessing the world; and our Lord understood that this was the attitude of heart of the disciples, intimating to them in the words of our text, "If any man will come after me" -- if he will have a place in the Kingdom, if he desires to be associated with me in that grand and glorious purpose of bringing blessing to the world of mankind, there are certain terms and conditions which he must meet, or he will never attain that glorious reward.

If any man come after me, let him deny himself, and let him take up his cross and let him follow

me. He did not say to them, "If you do not take up your cross and follow me, if you do not do what is my will, if you do not endure hardness as a good soldier of Christ, the God of Heaven has reserved for you a place in eternal torment." Then what will be the portion of those who do not accept this proposition of the Lord? Simply that they will not receive a place in the kingdom. To illustrate: President Roosevelt makes a special selection for his cabinet. He has before his mind a number of those who would be competent to accept these high offices and he makes a selection. There are many candidates for the office; there may be many who would be very competent in every sense of the word, but after going over all the field, he picks out those whom he recognizes will be worthy of the honor and trust that will be required of those who shall occupy these important positions. What about the rest? They do not get any punishment because they are not fully up to the standard, fully up to the mark he has set for those who should be members of his cabinet. Certainly not. They simply do not get the blessing, the favor, of being received into President Roosevelt's cabinet; that is all. What do those who are not accepted for these places afterwards get? They receive the benefits, and the assistance, and the favors, which are bestowed upon the whole country at large in the government that is instituted and carried out by this cabinet which the president has organized and brought into being.

It is the same with our Lord. The Father has sent Jesus Christ to be the great President, the great King, and now He is selecting His cabinet. There are many noble ones, fine characters, grand men and grand women in the world, but they do not all come up to the great standard that God has set. There are certain terms and conditions which the Lord has laid down, and if they are willing to come up to that standard which the Lord has set, then they may have a place in God's cabinet, in Jesus Christ's Kingdom, in the work of bringing a blessing to all the families of the earth. And that character, that disposition, which God has set as being proper, as being the kind of character and disposition that must be evidenced by every one who will be in the Kingdom, and in the work of blessing all the families of the earth, is indicated in these words of our Lord as He gave them to the disciples. And these words given to the disciples are just as proper to-day, dear friends, as they were then: "If any man will come after me, let him deny himself, and take up his cross and follow me."

Why is this? Because God is not taking the whole world of mankind to-day to bring to them the blessings and favor, but He is taking out the few. He has sent forth His message only to those who have the hearing ear and understanding heart. Only for these has He any message of blessing at this particular time. He has a message of blessing which shall be indicated in the grand time of opportunity for the world in the future, as evidenced by the words of the Angels given to the shepherds as they watched their flocks on the glorious Christmas night when our Lord was born, "Behold, I bring you good tidings of great joy which shall be to all people" -- in the future. But now at the present time only a few can hear or understand or respond and have the blessing in the Kingdom, because God has not yet chosen all of the members of that Kingdom class to bring a blessing to the world. If He had chosen all of the members of that class to bring a blessing to the world, the blessing would now be bestowed on the world, and all would be enjoying the favors that God intended shall be to the world in His own due time.

Our Lord intimated this very clearly when He said, "No man cometh unto me except the Father which sent me draw Him." If we had a proper understanding of these words, we would more clearly understand our text, and more clearly understand some of the puzzling questions brought

to our attention in our daily experiences. We ask ourselves frequently, Why is it that my friends, my relatives, my children, my aunts, my cousins, do not accept the truth? Why is it that I am blessed with such advantage, that I may share the favor of God's love, and understand so clearly the precious message of the Divine plan of salvation, and yet here are others who have even better minds than I have, and are not able to appreciate and understand these things. Why is it? It is simply because they have never been drawn. They have never had the understanding heart; they have never had their ears opened, because they were not of the condition of heart that God calls and recognizes. They are not of the kind that God could use in that glorious Kingdom. He wants only those who are honest, only those who are seeking after righteousness, only those who are looking and feeling after God if haply they may find Him. He may find them in various positions in the world. He may find a few among the great in the world, and many more He will find who are not so great, and some He may find among those who are ignoble, away down in the scale of human perfection, covered with degradation, and mire, and sin, and imperfection. But he finds all of those who are honest of heart, who really want to do right, and to these He sends forth the message; and as they hear it, that honesty of heart which they have immediately responds. Just as soon as the message comes that honest, righteous attitude of heart which they have been cultivating and manifesting hears, appreciates, understands, responds, and is turned to the Lord.

We have an illustration of this matter in the type. You remember how in the court arrangement of the tabernacle only the Levites were allowed to come into the court; all the rest of the eleven tribes of Israel were compelled to remain outside; they were not allowed to even look under the curtains of the court. They were not allowed to look at any of the sacrifices as they were being performed, and the walls of the court were so high that under ordinary circumstances there was no possibility of them looking in. Here was an intimation that God did not intend any of these things in the court to be for those outside, and did not want them to have any knowledge of it in any particular degree whatever. This represented that only those who have been justified by the precious blood of Christ, only those who are in the court condition, have any opportunity to see, and appreciate, and understand the blessings and favors of God.

But some one will say, How can that be? Is it not true that there are a great many people in the world who were sinful, who had no conception of religious things, who were going along their worldly, selfish way, and still they came to an appreciation of the truth? Many people are brought right out of the world into the truth who never belonged to a church. How do they understand the spiritual things which are inside? This way, dear friends. They are really anti-typical Levites, even though it may not appear so from the outside. If they were not anti-typical Levites, if they were not of the right attitude of heart, honest-hearted, the message would never have come to them at all. It is because they are of this honesty of heart, this righteous disposition, that the message comes to them. We may think of it in this way, in connection with the type itself. There were over 8,000 of the Levites, and the Lord sent the message forth to them, intimating that all of that tribe were to have the privileges of the court, to enter into the court, and to assist in the work of sacrifice. Some of them heard it immediately, some of them heard it a little later on, perhaps an hour or two afterwards, perhaps some did not hear it for a day or two afterwards, but eventually all heard it, and all had the opportunity of coming into the court and continuing the service that was ordained for them there. And so it is in the anti-type; there are many in this righteous condition who hear the message at once, and they immediately respond;

others hear it a little later on, and others hear it later still, but eventually all will hear it, and all will come to an understanding and appreciation if they are of the right attitude and wish to do the Lord's will.

And then we see another lesson in this type, of this matter. Some among the Levites may have said to themselves, "Well, it will be very nice, we suppose, to go in the court and do those things which are ordained for the Levites, but we will have to give up all our privileges out here. We do not want to do that. We want to stay where we are." And so for a time they are blinded by the earthly things; for a time they thought the things that belonged to the rest of the tribes of Israel were the best things; but by and by they began to appreciate the fact that those things were not the best after all; that the things which the Lord promised them were the best things, and appreciating that, they would leave their earthly things and accept what the Lord had indicated was the proper thing to do. And they may come into the court a little later on than any of the others, but still they would have the privilege of entering into the court because they were Levites. If they would maintain an obstinate attitude, and refuse to come into the court and accept what the Lord had indicated for them, they would not be counted Levites; the Lord would not regard them as Levites any more. But recognizing their opportunities and privileges as Levites, and accepting the favor of the Lord, then they would be allowed all the privileges which the court and the court conditions of the sacrifices there, had for them.

So it is to-day. Many do not appreciate the blessed things which are brought to our attention by the sacrifice of Jesus Christ; they recognize the privileges and favor which belong to the world, the opportunities that the world has, and think these are the best things; to accept Jesus Christ as their Redeemer does not appeal to them at first, because of the blinding influence of the earthly affairs; but after a while, if they are of honest heart, they will recognize that the earthly things are not worthy to be compared with the spiritual things, with the blessings and favors which God has for them; and having an honest heart they will come to an appreciation of that which they had at first neglected, and they will only do this because they are anti-typical Levites.

It is to these anti-typical Levites that our Lord addresses the words, "If any man will come after me, let him deny himself and take up his cross and follow me." Now, dear friends, let us examine that text, and as we look into it and see its rich meaning may it bring to our hearts refreshment and blessing, and a renewed determination to accept the will of God, and run patiently the race which is set before us, until we have finished our course with joy. Our Lord says, "If any man will come after me." There must be a willingness first. God would not accept any individual unless he is first willing to do God's will. God could not have accepted Jesus Christ until Jesus Christ had manifested His willingness. But we find, as our glorious example, our Lord Jesus was willing from the very beginning, as He said, and as it was prophetically stated of Him, "Lo, I come in the volume of the book it is written of me, to do Thy will, O God. I delight to do Thy will; Thy law is written in my heart." This was our Lord's attitude, and it must be ours. If we are not willing to do the Lord's will, then the Lord cannot accept us, then the Lord cannot do anything with us at all. We must have that earnest desire to be of the right attitude toward the Lord, to do what is pleasing to Him, willing to suffer with Him, and for Him, and willing to do whatever may be required of us as future kings and priests unto God before the Lord can use us at all.

There are some who are willing, but they do not know how to perform. We have an example of this in Saul of Tarsus. You remember he wanted to do what was right; he wanted to do the very best that he knew, and he himself explains his own attitude as a Jew, when he writes in the 3rd chapter of Phillipians regarding his various qualifications as a natural man: "If any other man thinketh that he hath whereof he might trust in the flesh, I more; circumcised the eighth day, of the stock of Israel, of the tribe of Benjamin, an Hebrew of the Hebrews; as touching the law, a Pharisee; concerning zeal, persecuting the church; touching the righteousness which is in the law, blameless." He was blameless because he was trying to do the very best he knew how to do. But that was not sufficient; he was not doing the right way. He did not recognize there had been a new dispensation inaugurated; he did not realize that now there was a new way in which he might manifest his faithfulness to the Lord, even of following in the footsteps of Jesus. He thought the old arrangement, the law arrangement, was the one that still obtained, and recognizing that there were some following in the footsteps of Christ, he thought they were doing what was wrong, and he wanted to save them from what he imagined would be to their detriment. So he went forth and persecuted them, because he believed by persecuting them he would bring them to a full realization of what he thought was their error. But God recognized that he had the right attitude of heart, that he was willing to do the Lord's will, even though he had a wrong conception of his duty, so the Lord brought to bear upon him the miraculous vision in order that he might appreciate and understand that what he was doing was wrong, and might be led into the right way. And you remember Saul's attitude as soon as he recognized that he was doing wrong, as soon as he realized he was acting contrary to the Lord's will; his earnest plea was, "Lord, what wilt Thou have me to do?" He wanted to do right; he wanted to learn the way of the Lord; he wanted to be in harmony with God's will; he wanted to be head right as well as heart right. Willing to do the Lord's will, but not knowing how to do it, he had thus far made a mistake; but we are glad to recognize the grand character of Saul of Tarsus, known afterwards as Paul, as he brought the message in such a precious way to all the Lord's people of that time and since. And, dear friends, that should be a lesson for us to-day, that as we are willing to do the Lord's will, let us see that we know how to do the Lord's will; let us see that we are properly instructed as to what the Lord's Word is as we are endeavoring to follow His will. It is not sufficient that we may have right desires; it is not sufficient that we be religiously disposed, go to church every Sunday, and do certain things recognized along each day, and only try to do what is recognized to be proper and right and just toward our fellow men, but we must have a clear appreciation and understanding of what is God's plan, and what is His purpose for the blessing of the world, and we are to bring all of our thoughts and energies into harmony with His will. And so the Lord intimates to us that those who are properly disposed, who as well as being willing to do the Lord's will are trying to know what that will is, will be instructed that they may understand clearly, and may have the opportunity of doing aright what God requires of those who will be His faithful disciples.

So He tells us here the way to go about it. As we are willing to do the Lord's will, He says first of all, "Deny thyself." How much that means, dear friends -- self-denial! Does it mean that the Lord wants us to give up our sins, and our imperfections, and our bad habits, and those things which were cherished as earthly, the things that belong to our natural feelings, frailties, the things that were recognized to be wrong? Are those the things He means when He says we must be self-denying? We answer no, those are not the things the Lord asks us to give up when we deny ourselves. We gave those up at the very beginning, just as soon as we recognized the Lord's

message coming to us, just as soon as we realized that Jesus Christ was our Redeemer, and that we were under the dominion of sin, and realized that only through Christ there would be an opportunity of salvation. Then we accepted justification. We appealed to the Heavenly Father through Christ to forgive us our imperfections, to forgive our sins, and to accept us through the precious blood of Christ, our Lord. Our Lord promised us and we trusted in that promise, that whosoever should come unto Him He would in no wise cast out. Then we were justified by faith. Then we gave up all those imperfections, and frailties, and faults; those were covered by the robe of Christ's righteousness, and we did not want to hear, or see, or think, about those things any more. We wanted to do what was right; we wanted to live according to our justification; but now the Lord presents to us something else. He says to these that have been justified by faith, Now you are somebody; before, you were nobody; before, you had no standing before God at all; you had no opportunity, no privilege to come into God's presence, because you were dead in trespasses and sins, and God could not look upon sin, or upon us as sinners. But now He can accept these, because they have been justified by the merit of Christ's precious blood; and to these that have thus been justified, He tells us there is something more to do -- self-denial. And through the Apostle Paul He puts the matter in a very concise way, Romans 12:2: "I beseech you therefore, brethren, by the mercies of God, that ye present your bodies a living sacrifice, holy, acceptable unto God, which is your reasonable service." Previously we could do nothing of the kind, because being dead, God could not accept such a sacrifice, as indicated in the typical arrangement; nothing that was dead, or diseased, or imperfect, could God accept as a sacrifice unto Him through the priests. It must be a perfect animal of its kind, if it would be accepted; it must be alive, and it must have no blemish, nothing superfluous, and nothing lacking in its whole make-up, and thus is intimated typically how we must be perfect, alive, and have something which God can accept. And through Christ, we have an offering that is worth something, and really is of value, because we are trusting in Christ, our Lord. Now it is this that is worth something which the Lord says we are to give up. Are we willing? Are we willing to deny ourselves in order that we may do the Lord's will? Here comes the test. Are we willing to give up things that are proper and right in the world, the honors and ambitions that belong to the world, the things that are so pleasant and congenial, which belong to our earthly existence? Are we willing to lay these aside? There is nothing wrong or sinful about them, but are we willing to show our faithfulness to the Lord laying these aside? What does the Apostle say? The Love of Christ constraineth us, because we thus judge that if one die for all, then were all dead. And if He died for all, we who live should not henceforth live unto ourselves, but unto Him who died for us and arose again.

When we look at the glorious work our Lord Jesus accomplished on our behalf, leaving the glory He had with the Father before the world was, making Himself of no reputation, giving up everything in order that He might redeem the world from death -- when we realize all that love accomplished on our behalf, should we not say,

*"Were the whole realm of nature mine,  
That were a present far too small --  
Love so amazing, so divine,  
Demands my love, my strength, my life, my all."*

Everything that we have is so little in comparison with what our Heavenly Father has done for

us, that if our Heavenly Father is willing to accept us, we are glad to give it to Him in order that He might use us to His own praise, and glory, and our spiritual profit. Deny ourselves? Yes, we will deny ourselves; glad of the glorious opportunity of thus being servants of the most high God; glad to know that our Heavenly Father is willing to take such poor, weak, frail vessels as we are and to use them to His glorious praise. If God is willing to accept us, should we hesitate one moment in accepting what He has offered to us? And yet, dear friends, there are many who are not willing to deny themselves, many who cling so earnestly and tenaciously to the things that belong to the world, because they think these are real and vital. But no, dear friends, they are not. Let us pray to the Lord that He may give us a clearer appreciation of the things that are vital, the things that are real, the things that are worth anything to us, in order that we may appreciate more and more His glorious love and favor, and the privilege in due time of entering into the Kingdom which He has promised to those who are thus ready to show devotion and loyalty to Him. Let us deny our justified self, and lay it upon the altar of sacrifice, until it has been completely consumed, until it has all been burned, and we shall have the glorious entrance into the Kingdom. But if we are to properly deny ourselves, we must carry out the covenant which the self-denial brings to us at the very beginning. The Apostle in the 3rd chapter of Phillipians reminds us of his experience, and tells us something of the difference between self-denial and cross-bearing. You remember how he says the earthly things he had enjoyed as a Jew while they were great, honorable, grand, and in every way proper, nevertheless he counted it all joy to give these up, and to suffer the loss of all things -- counting them all loss, as he puts it. He denied himself, he made the consecration; he offered himself in sacrifice to the Lord. But he proceeds to show that it is not sufficient to count these loss; it was not sufficient for him to say that he was willing to do God's will; it was not sufficient for him to make that consecration to the Lord; it was not sufficient for him merely to offer himself in submission to the Heavenly Father's will; but it was also necessary for him to continue what was begun at the consecration, until the day of the Lord Jesus, until the sacrifice was fully consumed. Yea, and I have suffered the loss of all things, and do count them but vile refuse that I may win Christ and be found in Him.

And so with us, dear friends, as with the Apostle. It is necessary for us, not only to count all things loss, not only to will to do the Lord's will, but it is also necessary for us to be faithful if we are going to have a place in the Kingdom. "Be thou faithful unto death, and I will give thee a crown of life." Not that we might start on the way and then we will get the crown of life, but we must be faithful and loyal until we have completed our course in death; and then if we have suffered the loss of all things, we are promised that we may have the glorious reward on the other side of the veil. Are we willing to bear the cross? Are we willing to do what is the Lord's will even unto the end of the way? If we are, then we shall have the reward of the Kingdom, and a share in the blessing of all the families of the earth.

When I think, dear friends, about this matter of cross bearing, faithfully following in the footsteps of our dear Lord, I think of the various difficulties and trials that come to the Lord's people. The Lord has not indicated to us that we may choose our own cross, but the Lord has given to us certain experiences, which He knows will be for our development, as new creatures in Christ Jesus. And if we recognize that, dear friends, we will never complain as to what may be our experiences.

Perhaps it is our disposition to complain; perhaps we are inclined to think, Well, if I had the



cross of Sister Smith, or if I had the cross of Brother Brown, I could bear that better; I could do that all right, that is not so hard as the difficulty I have to bear; it may seem harder, it is larger perhaps, but there are many little difficulties and trials that come to me, and they are so hard for me to bear. The Lord gives the other brethren something hard, and if He would give me something hard like that I could bear it, but this petty annoyance that is constantly irritating me, if the Lord would only take that away, it would be so much easier for me to pass along the way and attain the reward in the Kingdom. If the Lord thought that the other thing would be the best for you or the best for me, don't you think that He who is caring for us in all our interests would see to it that we got that?

I think of a dear sister living not far from Allegheny; she is associated with the Allegheny congregation, but she is never able to attend any of our meetings, because she is a cripple. She has to sit in her room all day long, all the week long, and all the year long; she is not able to move out of her chair. Some one has to attend her constantly; her limbs are rigid and her body is rigid and her neck is rigid; she can hardly turn her head as some one comes into the room; she is just able to move her fingers a little bit in order to do some crochet work. Dear friends, I have gotten some of the most encouraging and blessed experiences in the room of that dear sister that I have ever had. I remember, just before coming to this convention, I went to see her, and she was sitting in her room, and as I entered she could not turn her head to look at me, but as soon as she heard my voice and knew that I was there she said, Brother Fred, I am so glad to see you, and her face lighted up with such a glorious smile. And as I greeted her I said, How are you, sister? Are you suffering very much? She said, with a smile, I am always suffering, but it don't matter. If she was suffering in her body, there was a realization of God's presence by His holy spirit; she knew that God was with her and was able to sustain and keep her by His mighty power and that the sufferings of the present time were not worthy to be compared with the glory that shall be revealed in due time. That dear sister, in that little room, has been able to preach more eloquent sermons of help and assistance to the Lord's people who have come in contact with her than many others who have been preaching in eloquent tones to thousands in a congregation, because she is one who is really having the assistance of the Lord, and the blessing and favor of the Lord, and really laying down her life in her fullness of faith in endeavoring to do what is pleasing in God's sight. I have often thought that if it is possible for that sister under such conditions to be faithful, how much more possible it should be for us who are healthy and strong, who have all of our faculties and capabilities, going about from place to place and attending meetings and conventions, and having fellowship with others in large gatherings -- how much more possible it should be for us to be full of faith even unto death and realize that the Lord is able to sustain us, even as He is able to sustain that dear sister.

So let us be faithful in bearing our cross; let us be faithful in bearing the petty annoyances and the difficulties and trials that come to us. How often we may say to ourselves, the cross is so irksome and so hard to bear, if we could only get free from it for a little while, say for a week or two or for a year, and feel that we did not always have to bear this burden, and walk along this narrow way. Sometimes we get into this condition because the Adversary, knowing some of our weaknesses, may attack us just along that line. But let us see to it that when any such suggestion comes to us we put it away immediately. Let us hold fast that which we have. We must hold fast to the cross if we are going to attain the Kingdom. Let us remember that the cross must be borne if the crown is to be worn; that we must die with the Lord if we are to live with Him, that we

must bear the burden and the trial and the difficulty on this side the vail, if we are to have the joy and the rejoicing on the other side of the vail. If that be true, how loyal it should make us in every experience of every day! How it should help and assist us, that in every thought and word and deed, in the least things of every day, we should try to be pleasing to our Heavenly Father, that we should see to it that in our walk and in our conversation, whether it be in the home or office, or shop, or store, or on the farm, or in the mines, or wherever it may be, that the light of God's love is shining forth in our faces that others may be able to see and recognize that we have been with Jesus and learned of Him, and are seeking to do His will. If we are doing that, bearing the cross, no matter what it may be, and faithfully striving to show ourselves loyal and true to our Heavenly Father, there is no doubt as to the result, for the Apostle says that if we do these things we shall never fall, for so an entrance shall be ministered unto us abundantly into the everlasting Kingdom of our Lord and Savior, Jesus Christ. Having that precious promise before our minds, what encouragement it should bring to us! There is no possibility of our falling so that we would never rise again if we are doing these things, faithfully cultivating the fruits of the Lord's holy spirit. That being true, let us take renewed courage, and taking the Lord's promise, let us be faithful unto death in doing the things He says are proper and right for us who are endeavoring to bear the cross, recognizing it is necessary for us to do these things and be faithful in the little things as in the greater things.

I remember two years ago getting a lesson along that line that I shall never forget. There were two colporteur sisters visiting at the Bible House. They were leaving for a distant city in the West, and a number of the Bible House friends had gone to the train to say good-bye to them. And as we went to the station, the guards kindly allowed the party to go up on the platform and wait for the train as it came in from Pittsburg to carry the sisters on their journey. And as we were standing on the platform there, we were saying good-bye to the sisters, telling them of our earnest hopes for their future, and that the Lord's blessing would be with them, and while we were in some sense of the word, perhaps, sad to know that they were going to leave us, nevertheless we were rejoicing in the precious things our Lord had bestowed upon us, glad to know of all the blessings and favors that God had given to us, and I presume this showed forth in our faces. In a moment or two the train came in and the last good-byes were said, the sisters got on the train and went upon their journey. It was an ordinary circumstance; there seemed nothing special about it. After the train had left we turned and went back to our work in the office, considering it as a comparatively ordinary happening. It passed out of our minds to a more or less extent, but a few months later I heard the sequel to that little incident, as it took place on the platform of the Fort Wayne station at Allegheny. After the sisters had gone on their journey for some distance, a lady on the opposite side of the car had occasion to speak to one of them, and after she had spoken, the lady said, By the way, are you ladies not Christians? And the colporteur sisters said, Yes, we are; glad of the opportunity to testify that they belonged to the Lord, and were seeking to do His will. And the lady said, I thought you were. This morning, when we came into the station at Allegheny I saw your happy, smiling faces, and saw your friends there saying good-bye to you, that I could not help being impressed and I said to myself, those people must be Christians. Oh, I wish I were like that! Won't you tell me something about it? And then the dear sisters had the opportunity of opening up the Word of God and telling to a hungering, thirsting soul something of the precious plan of salvation, and something of the peace that they had found; and as she heard the message and realized that it was founded upon the Word of God, it brought comfort and joy to her heart. She said, I have not been a Christian, I have been outside the church

and the things that belong to the church, and I have not been trying to live a Christ life, but you have told me something that is worth while. There, in that railway carriage, they had the privilege of testifying for the Lord and manifesting to that hungering and thirsting one that they were the Lord's children. As I heard that story, I realized how responsible we are for every act of every day. The little things of daily life are part and parcel of our privilege of cross bearing. Sometimes, dear friends, it may be hard for us to smile; sometime, it may be difficult for us to give that testimony in our faces which should be the testimony of all the Lord's people, because of the trials and the difficulties which we must continually contend against. But the more we cultivate it, and the more we realize that the Lord's blessed favor is upon us the more we can cultivate it, and all the more will we have the privilege of showing to others that we have been with Jesus and learned of Him. If we are doing that, if we have been doing the Lord's will, if we have denied ourselves, if we are taking up our cross in everything every day, then we are following Him, and if we are following Him, we will have the privilege of entering, in due time, into the Kingdom. It was necessary for our Lord, as indicated by the type, to go without the camp, bearing the reproach of the world, and the scoffing and the shame, and it is necessary also for us to go to Him without the camp, bearing the reproach with Him; but if we are faithful in doing this, we are promised that we shall have a glorious reward.

Yesterday afternoon, when we had assembled at that glorious service on the bank of the Niagara River, I could not help thinking of the picture that was presented there; and one of the features of that service especially impressed my mind. You will remember how, after Brother Russell had finished his address, on the sloping bank above the rapids, the crowd dispersed and the vast concourse came down the roadway, and when they came to the bridge that leads to the island where the tents were erected, and the immersion was to take place, there was a separation. The concourse of people went down the road -- a broad road it was -- and a few, comparatively, separated there and went through the narrow way, which was a small place wide enough for three persons to pass through, and these passed on the bridge over the water. And as Brother Russell and I shook hands with them, I could not help being impressed with the solemnity of it. Here were a few offering themselves in symbol to be immersed, representing their full consecration to the Lord; it meant a separation of them from the world, and from all the interests and concerns that belonged to the world, and it meant for them an entrance into the blessings and favors which the Lord has for those who are faithful in doing His will. But not many are willing to do this; just a few, and these are promised that they shall have the glories of the Kingdom in due time. Ultimately it will mean that they shall cross the Jordan of death, and as they have finished their course in death, then, having passed beyond the veil, they shall receive that which the Lord has intended for them, blessing and favor and peace and joy. This being true, dear friends, may the peace of the Lord rest with our hearts -- that kind of peace that our Lord promised to us, when He said, My peace I give unto you.

Knowing that this be true, dear friends, how our hearts rejoice as we realize all that the Lord promises us, and may we be enabled by the Lord's grace to say that we will be faithful unto death; that having willed to do the Lord's will, and having denied ourselves and given ourselves in consecration, now we want to follow in His footsteps by being faithful cross-bearers, even to the end. And that being true, may the prayer of our hearts be, in the beautiful words of the poet:

I want that adorning divine,  
Thou only, my God, canst bestow;  
I want in those beautiful garments to shine,  
Which distinguish thy household below.

I want -- Oh! I want to attain  
Some likeness, my Savior, to Thee,  
That this longed for resemblance I at once may attain,  
Thy comeliness put upon me!

I want to be marked for Thine own,  
Thy peal in my forehead to wear;  
To receive that "new name" on the mystic white stone  
Which none but Thyself can declare.

I want so in Thee to abide  
As to bring forth some fruit to Thy praise.  
The branch which Thou prunest, though feeble and dried,  
May languish, but never decays.

I want Thine own hand to unbind  
Each tie to terrestrial things --  
Too tenderly cherished, too closely entwined,  
Where my heart too tenaciously clings.

I want, by my aspect serene,  
My actions and words, to declare  
That my treasure is safe in a country unseen --  
That my heart's best affections are there.

I want, as a traveler, to haste  
Straight onward, nor pause on my way;  
Nor forethought, nor anxious contrivance to waste  
On the tent only pitched for a day.

I want -- and this sums up my prayer --  
To glorify Thee till I die;  
Then calmly to yield up my soul to Thy care,  
And breathe out, in faith, my last sigh!

## 7 P.M. -- Praise Service

*led by Brother John Hoskins, of St. Paul, Minn.*

## 7:30 P.M. -- Symposium on "LOVE"

**by Various Speakers, -- and "LOVE FEAST."**



Brother Johnson.  
Brother Kuehn. Brother Wise.  
Brother Jones. Brother Page. Brother Barker.  
Brother Mills. Brother Dann.

## **BRO. WILLIAMSON**

This evening's service will be a worthy culmination of our convention, although we will have two more days of blessed fellowship together, and surely we rejoice in this prospect. This evening we are to have a "love feast," which has always been such a precious opportunity of fellowship and communion with one another and with our dear Lord; and on this occasion I want to remind you again of the text which I used in connection with the opening of the convention. Do you remember it? "The Lord bless thee, and keep thee. The Lord make His face to shine upon thee, and be gracious unto thee. The Lord lift up His countenance upon thee, and give thee peace." Dear friends, has my opening wish, expressed the first day of the convention, been fulfilled? Surely it has. Surely we have had the most blessed time we have ever enjoyed. Surely it has been a time of much refreshing blessings, profit and peace, and joy. Surely we thank the Lord out of the fullness of our hearts for all His gracious love towards us. And on this the evening of our "love-feast," I am sure our hearts are knit together with a closer bond of love, and peace, and unity in Christ, than ever before characterized our experience. We rejoice in this, dear friends, and as we go to our homes in a few days with our hearts filled to overflowing with the blessings we have enjoyed, we shall have the further blessed privilege of pouring out the blessings we have received to others, and then the Lord will continue to strengthen and refresh, and continue the blessings we have been having here. This does not end the blessings we have been receiving. No, no, our blessings are to continue and are to increase, giving forth to others of that which we have received, and assuredly we will realize that it is more blessed to give than to receive. And now as we have been receiving, and as we have been endeavoring to give during these days of convention, I trust that the season has been one of profit to us, and that our privilege and opportunity is now in sending forth to others, to the full extent of our ability, some of the blessings of the truth which we have been enjoying together. So may we all take to heart

these lessons, dear friends, and rejoice continually in the Lord's loving kindness, and favor, and mercy, toward us.

After singing of hymn 165, Bro. Russell addressed the convention for ten minutes on the subject,

## **"Love is the Principal Thing."**

Brother Russell said: "Dear friends, it was the intention to have the various themes of Love considered first, and love itself as the finality, but since there is a meeting down stairs, and one up stairs, it became necessary to divide the matter a little, and so I will have a word with you on love first, and then you will hear more about the various divisions of love afterward.

Our little talks are to be very brief, you know, and mine will be of the same order. I take as my text, "Love is the principal thing." We might ask why love should be considered the principal thing? Why not have justice the principal thing? Why not have wisdom the principal thing? Why not have knowledge the principal thing? Why not have divine power the principal thing? But the Lord tells us from His standpoint -- and that is your standpoint, and my standpoint -- love is the principal thing. I think it will do us all good to have in mind that, no matter how much knowledge we should have, no matter how much wisdom we might acquire, no matter how much power we may be able to exercise, all these things are secondary from God's standpoint, and the measure of love you and I can acquire will be our measure from God's standpoint. Therefore, how much you are in God's sight, how much you grow from day to day, and from year to year, in God's sight, in God's estimation, depends upon how much love you have incorporated into you, how much you are built up in love, how much you grow up in love, and in all the affairs of life as it will extend and affect all the interests of life.

I remind you, dear friends, the Scriptures tell us that "God is love." Nowhere do they say that God is justice; nowhere do they say that God is wisdom; nowhere do they say that God is power. It is true that God is powerful, it is true that God is wise, it is true that God is just, but He is not any of these things per se; but God is love. In other words, the word love represents the whole character of God, and all the wisdom of God is that kind which proceeds from and is in accord with love, and all the power of God is exercised in conformity with His love, His character of love, and all the justice of God is in full accord with this essential feature of His character, love. No wonder, then, if God Himself is love, that He tells us, "Love is the principal thing." God is the principal thing, and God is love. And then in proportion as you and I would come into harmony with God, and in proportion as you and I would become God-like, and in proportion as we would be pleasing in our Heavenly Father's sight, we must have this same element of love; and in becoming God-like we are becoming loving and lovable.

We see, dear friends, how the loss of love came in. We see that through the fall, man who was made in God's image, and who therefore must have been a very loving being to begin with, as he came to struggle with the affairs of life, with the thorns and thistles, and with everything that was around him, developed the lower organs of the mind, the selfish propensities, the tendency to take for self, and to look out for number one, and how this was all maintained at the expense of the higher organs of love, benevolence, sympathy, kindness and generosity. All of these suffered as he must battle for himself with thorns and thistles which the earth brought forth to him, and in

order to gain his bread by the sweat of his brow. So we see that 6,000 years has reduced our race -- the race that originally was in God's image and therefore was in the image of love -- to that place where, as we see today, selfishness is the prominent and dominant quality of the human family. And we see, in a word, God points out to us that during the great time of trouble which is coming, the very thing that will be the source of all the trouble, and the cause of all the trouble, will be selfishness. Every man's hand will be for himself and against every other man. All of this, you see, will eventuate, as the Scriptures show us, in the collapse of present institutions, when all the affairs of men will go down in the great maelstrom of trouble, when society will be entirely wrecked. Selfishness will be the cause, and God is allowing this illustration of selfishness as it began when man lost his harmony with God, and which has progressed and swept over the world all through these 6,000 years, to heap up in this great time of trouble which will be chiefly caused by knowledge and selfishness. While men were ignorant they could not all use their selfishness to any great extent. Some few could use their selfishness, and the others were powerless to understand and appreciate the operation of it; but now we come down to a place where everybody has knowledge, and everybody has selfishness, and when you get the whole human family into a great battle each to get the better of the other, you have the cause of the great trouble that is right upon us.

What should be our attitude, dear friends? Our attitude is to be in harmony with God. God has called us to be transformed by the renewing of our minds. Our minds, like those of the remainder of mankind, are selfish. We are sometimes ashamed of the selfish things we do now. We think there is no exception. You see something you have done after you have done it, and you see there was some selfishness in it; you were not aware of it at the moment. The reason is, you have a higher standard in your minds now; you are able to see these little mean things; you did not see them at one time, but the more you see of the glorious character of the Lord the more you realize that He is our pattern, and that we are to be God-like, and that love from God's standpoint is the principal thing. The more we realize that, dear friends, and the more we seek to put down all selfishness and meanness, and to get rid of these, and get the new nature built up, the more we are coming into the likeness of God, and becoming copies of God's dear Son. And then it is in that connection we are to remember the words of the Apostle in Romans 8, that God has predestinated that all those who shall be joint-heirs with Christ shall be, and must be, copies of His Son, and that means that you and I must gain a victory over selfishness.

But you say, Brother Russell, can we hope ever to get where we are above selfishness? Could we ever hope to reach that point? If God is going to set that standard, that we are to be copies of God's Son, we have no chance at all. I answer, dear friends, we have no hope at all of ever getting to that perfect standard at which our Lord was; we have no hope of getting rid of all the meanness as long as we have these mortal bodies. What we have hope for is this; that in the spirit of our minds we are to get in that place where we will hate iniquity, and hate selfishness, and where we will love God, and love benevolence and love that which is lovable, that which is loving. When we have reached that point in our minds, and are striving to bring our bodies as far as possible into conformity with that, we have reached a place in the spirit of our minds where God is measuring us not according to the flesh but according to the Spirit. And therefore you see it is for us to have this right standard in our minds, and as we have that standard, and God recognizes our intentions, and our efforts, and our endeavors to perfect love in our hearts, in our lives, and in all that we do -- in that proportion we are accepted in Christ Jesus. How blessed is

God's arrangement, and how harmonious it is with everything that would be reasonable in our sight.

Now, dear friends, I have had my ten minutes, and I am very glad to have had this opportunity of saying a parting word with you all. God bless you. I will shake hands with you all. Shake hands with me if you please.

(Brother Russell waving his hands and the audience responding by waving theirs. This was Bro. Russell's good-bye as he left the meeting to take the train for home. As Bro. Russell left the platform the audience sang, "God be with you till we meet again.")

## **Meekness as a Quality of Love.**

By Brother W. E. Page, of Milwaukee, Wis.

Dear Friends: It gives me pleasure to-night to address you on this wonderful topic in one of its phases. When we look at the definition of meekness, we find that it means submissiveness, mildness, and the text we have taken is the admonition of the Lord when He says, "Come unto Me all ye that labor and are heavy laden, and I will give you rest; learn of Me for I am meek and lowly in heart, and ye shall find rest for your souls."

We know that the world as a whole looks at meekness as a very undesirable quality. It seems in the minds of most people to be associated with the thought of inefficiency; and yet when we recognize that the one great quality the Lord invited us to possess as we approached him, was meekness, we know that no such thing as inefficiency can dwell in this quality.

If we are to learn of our Lord, we are to learn to be submissive under all the various relations in life. Meekness is the opposite of pride; if we are meek we will not think of ourselves more highly than we ought to think, but we will think soberly, as God has given to each one of us the measure of faith.

You will remember the gracious promise with which our Lord supplemented meekness. "God resisteth the proud, but giveth grace (favor) to the humble" -- to the meek, the same thought. It was also promised that God will guide the meek in judgment, and teach the meek His way. How graciously our heavenly Father has been fulfilling this promise to us, as we have learned of the Lord to be meek and lowly in heart, guiding us into judgment, so that we may examine ourselves and not come into judgment with the world. And then He is teaching us His way, that we may walk in it. We remember that other wonderful promise, that the meek will inherit the earth; and we believe that as inheritors of the earth, we will be equipped to bring to the earth that wonderful blessing, the blessing of the restitution of the earth, and then we remember again how this has an effect in our lives. It gives us helpfulness with our brethren. "If a brother be overtaken in a fault, ye which are spiritual restore such an one in a spirit of meekness." Again you remember how the Apostle Paul gives us an incentive when in speaking to the Corinthians he says, "I beseech you by the meekness and gentleness of Christ." So we want to attentively consider Him in this quality of meekness, and He was meek and lowly in heart. It was this quality of meekness in our Lord that led Him to abase Himself, and therefore it will help us to abase ourselves, and to take the



first step in being transformed into the image of the Son of His love.

## **Gentleness and Its Relation to Love.**

By Brother Smith Walker, of Philadelphia.

Dear Friends: I presume a portion of you at least are somewhere near the beginning of the Christian race, and possibly you might have been a little disturbed like I was at about the same period. How I rejoiced to be led out of darkness into God's marvelous light, and when I began to study over the terms and conditions I came face to face with the statement that it was necessary to cultivate and develop love, and to some extent I was a little dismayed, because it seemed to me that love was not within the control of my will. But we may rest assured that our Heavenly Father has made full provision in His word for the development of this class that He has been calling during the last eighteen hundred years, and if we search His Word we will find this feature has not been neglected either.

As a capable chemist can analyze any substance submitted to him into its constituent elements, and tell exactly of what it is composed, so we find that love is dissected and analyzed in God's Word, and when we come to an understanding of the elements of which it is composed we see that all of these elements are under the control of the will -- that is, of a will submitted to the will of God -- and may be earnestly cultivated.

Gentleness might suggest softness, smoothness, easiness of mind, pleasantness of conduct, just as the opposite quality of rudeness suggests hardness, friction and pain. When we were small children, some of our playmates were rough and some were gentle, and if we were gentle ourselves, we realized how much more pleasant the agreeable and gentle ones were than the rude ones. Pleasantness signifies such a consideration of the feelings of others that we would be careful not to do anything to cause either physical or mental pain. We may form a conception of the matter by considering the effect which would be produced by a world of men animated by a spirit of rudeness, when every injury was retaliated, in comparison with a world of persons where all were gentle and easily entreated. We have been enlightened in advance of the balance of mankind, and we have been enabled to see that there is a time coming when there will be no sentiments whatever permitted to exist which are in conflict with love in all of its phases, and if we receive this exceedingly great favor it is incumbent upon us to show our appreciation thereof by reducing earnestly to practice the lessons intended to be brought to our attention thereby.

How may we make progress along this line? First, by taking careful survey of the field, we might use our own feelings, and consider what it is that hurts us, and causes either mental or physical pain, and then be very careful to be even more considerate in that respect of all others. Second, we might carefully consider this matter at the beginning of each day, and carefully guard against any set of circumstances which might have a tendency to awaken whatever of rudeness there might be slumbering in our dispositions; we might also carefully take a survey at the close of each day, and note where and how we failed, earnestly striving to profit by our past mistakes. And thus we certainly would see some development and growth along these lines.

## **Patience as a Quality of Love.**

By Brother T. E. Barker, of Boston.

Dear Friends: I will call your attention to Romans 5:2, "by whom also we have access by faith into this grace wherein we stand, and rejoice in the hope of the glory of God." It is a question with many to whom the Apostle is addressing these remarks. Verse 3, "And not only so, but we glory in tribulation also: knowing that tribulation worketh patience." We glory in tribulation, not because we love tribulation, but because tribulation worketh patience; and patience, experience; and experience, hope. And hope maketh not ashamed, because the love of God is shed abroad in our hearts by the Holy Spirit which is given unto us.

The second citation is found in Luke 21:19, "In patience possess ye your souls." These words are from the lips of our dear Master. Patience in the Scripture carries with it a deeper meaning than has generally been given to that word. It has the sense of endurance, cheerfulness, constancy. "In your cheerful endurance possess ye your souls." In what way? God's true children can indeed possess their souls, their lives, and enjoy them, even amidst tribulation, with cheerfulness and constancy.

The third citation is found in James 1:2, 3, 4, "My brethren, count it all joy when ye fall into divers temptations, knowing this, that the trying of your faith worketh patience. But let patience have her perfect work." Surely, dear friends, we can permit the great controlling influence of cheerfulness to work in our beings because the call is high, and the reward is great.

The fourth citation is found in Hebrews 10:36, "For ye have need of patience (cheerful endurance), that, after ye have done the will of God, ye might receive the promise." We have no need to tell you what the promise is, dear friends.

The fifth citation is found in Hebrews 12:1-2, "Wherefore, seeing we also are compassed about with so great a cloud of witnesses (note the thought: the cloud of witnesses referred to are those old testament worthies and prophets who must have developed a large measure of patience in their character development to commend themselves to God as being worthy of a better resurrection) let us lay aside every weight, and the sin which doth so easily beset us, and let us run with patience the race which is set before us." Let us not get weary in the race. It is almost over, and ere long our course will be finished.

The sixth citation is found in 2 Peter 1:5-6, "And beside this, giving all diligence add to your faith virtue; and to virtue knowledge; and to knowledge temperance; and to temperance patience; and to patience Godliness." Let us see to it, dear friends, that this necessary element of patience is in the process of perfecting every good thing in us. "Let patience have her perfect work."

The seventh citation is found in Titus 2:2: "That the aged men be sober, grave, temperate, sound in faith, in charity, in patience." The Apostle Paul on more than one occasion ranks patience beyond love, which is the mark of character to which we are to attain, the mark of the prize. Though the Christian have all the other qualities, the final test of patience, cheerful endurance must be passed before we could be acceptable of the Lord as members of the very elect. How can this quality of patience rank higher than love? It is not merely to come in at the close of our race,

but is required all along the race course. It is required of us that we shall stand up to the mark faithfully, cheerfully, patiently, and endure the test, which the Lord will even then see fit to permit to come upon us. Hence it is that the apostle exhorts us that having done all to stand, to endure; having reached the mark, let patience have her perfect work. When the night comes wherein no man can work, it will call to our attention this cheerful, patient endurance, waiting God's due time for our change. May God help us to be faithful, and develop more and more of the character of patience.

## **Brotherly Kindness.**

By Pilgrim Brother R. E. Streeter.

Dear Friends: Kindness is defined by Webster to be benevolence. This phase of love, like all the other graces, of course, is manifested in its perfection and fullness in God. And so we read in the Scriptures of the kindness and love of God. And we have the Apostle exhorting us to imitate our Heavenly Father, and His dear Son, our Lord Jesus Christ. "Brethren, be not weary in well doing, for in due season we shall reap if we faint not." As ye have opportunity do good to all men, especially to them who are of the household of faith. We say we are imitating our Heavenly Father, for His kindness and love was manifested in giving. Then kindness is, from the Scriptural standpoint, simply love exercising itself in benevolent action toward the undeserving, for we were undeserving of our Heavenly Father's favor.

Brotherly kindness is the kindness manifested by brothers to brothers. The brotherhood referred to here is not the natural brotherhood, the fleshly brotherhood. The brotherly kindness referred to here is not the social brotherhood of the organizations which are formed by men for the purpose of helping one another. But rather does it refer to those who are realizing God's kindness and benevolence, as manifested in the giving of His dear Son. This is the brotherhood -- those who are trusting in the merits of our Lord Jesus Christ's sacrifices, and those who realize that they are now accepted only through the merits of His death. There are two classes referred to as we understand the Scriptures. There are those who have applied the justifying grace of God; then there are those who have not only been justified through God's favor, but through gratitude and love to Him, for what He has done for them, have covenanted to follow in the footsteps of the Lord Jesus Christ even unto death. These two classes are referred to by the Apostle when he speaks of doing good to the household of faith.

In the consideration of this brotherly kindness several things are necessary to keep in mind. First, our thoughts toward the brethren. Let us have our thoughts right toward them. Let us think of them as our Heavenly Father thinks of them. And when we come to consider the fact that we are made acceptable through the merits of Christ, and that this holy priesthood is taken from all classes and conditions, and from the natural standpoint we might say some are more worthy of God's love and kindness than others, but from the standpoint of God all these are made acceptable through the merit of Christ's sacrifice. Let our thoughts be toward the brethren as our Heavenly Father's thoughts are toward us. He does not judge us according to the flesh, but as New Creatures in Christ Jesus. Then we exercise this kindness by our words -- kind words. Finally our actions. You all know that these three things cover the whole ground. Our actions! Oh, how much we can do for the brethren! There is not a single brother but what can help another brother, for God has so constituted us that we all need help along some line, and we can

all be helpers one of another and thus develop this phase of the grace of love, brotherly kindness.

## **Godliness.**

By Brother W. J. Mills, of Hamilton, Ontario.

Dear Friends: The desire for Godliness or God-likeness, I believe should be the chiefest desire of every fully consecrated child of God. I believe it is the desire of every one present in this room tonight, or the majority at least. Why so? Because we believe the majority of those present are fully consecrated to the Lord, having been begotten of His holy Spirit and desirous of growing like God. It is impossible for us to copy the likeness or the character of any individual unless we know the character and the likeness of that individual. And so it is impossible for us to cultivate Godliness unless we know something of the character of God. We are glad tonight, dear friends, because we have been brought to know something of the attributes of God, which are justice, love, mercy, and power. I will just draw to your minds two pictures of the love of God. Romans 5:8: "God commendeth His love toward us, in that while we were yet sinners Christ died for us." 1 John 4:10; "Herein is love, not that we loved God, but that he loved us, and sent His Son to be the propitiation for our sins." 1 John 2:2: "And he is the propitiation for our sins, and not for ours only but also for the sins of the whole world.

Here we have the picture of God showing love to the whole groaning creation. It is not to His own, to those who loved Him, but it is to those who are strangers and aliens from God; who are not only sinners but enemies of God; God so loved them that he gave the dearest thing He had, His only begotten Son, to die on their behalf.

Dear Friends, we can cultivate godliness and grow like God. We can love the groaning creation, and we can love those who do not love us. It is not as easy to love those who hate us, but, having the holy Spirit of God begotten in us, having the mind of God, then we begin to love not only those who do not know us, but we love those who are our enemies, and in so doing we are cultivating godliness and growing more like God.

The other picture we find is recorded in Romans 5:10: "For if, when we were enemies we were reconciled to God by the death of His Son, much more, being reconciled, we shall be saved by His life." The thought is this, that if, when we were sinners and strangers to God, we were loved so by Him that He gave His Son to die on our behalf, do you not think the Lord loves us a great deal more when we have accepted the provision which He has made and are now endeavoring to conform our lives to the life of the Lord Jesus Christ, and grow like the Heavenly Father?

Some one might ask, Is it possible for us to develop this God-likeness? In 2 Peter 1:5 we read: "And besides this, giving all diligence, add to your faith virtue; and to virtue knowledge; and to knowledge temperance; and to temperance patience; and to patience Godliness." So you see, dear friends, that we can develop this characteristic of Godliness. We can grow more like our dear Heavenly Father. Some one might say, Well, how can we grow like our Heavenly Father? Why the words of our dear Brother Johnson are still ringing in my ears. We let the mind of God which we gather through the study of His Word, take possession of our minds, and so charge the affections of our hearts that it will wean us away from earthly things, and help us to set our affections on heavenly things, and you will then walk after the spirit; we will become spiritual,

will become godly.

It is not possible as long as we are in the flesh to be exactly like God, but there is coming a time when we are going to leave this flesh. I heard two of the dear sisters singing this afternoon, that the day would come when this earthly house would fall. But I thought, dear friends, that when the earthly house fell the Lord was going to give us a heavenly house, one that would never fall, one that you would have throughout all eternity. Soon, when it is God's due time to take away this earthly house, this fleshly body, then God will give us a spiritual body; one that will never fail us.

Beloved now are we the sons of God. It doth not yet appear what we shall be, but when He shall appear, we shall be like Him -- Christ.

"We shall be like Him. O, how rich the promise!  
What greater could our Father's love prepare?  
Few are the words, and softly are they spoken,  
But who shall tell the glories hidden there?"

Brother Williamson: Meekness, gentleness, patience, brotherly kindness -- the sum of all these is love, and they illustrate our Heavenly Father's glorious character; and as we are seeking to cultivate these elements in our hearts, we are cultivating God's character. I trust, dear friends, that all of us are growing in love, and as we have been enjoying the blessings of love in this association together our hearts are full of love so that others may be able to see clearly as we are seeking to demonstrate the fact, that we are trying to do God's will, and to be more and more lovely and loving.

## **SYMPOSIUM OVERFLOW.**

### **Meekness.**

BROTHER PAUL S. L. JOHNSON: Meekness is one of the elements of love. By meekness, we understand the proper estimate of one's self, as the Lord looks upon us. Not such an estimate as is below what the Lord puts upon us, indicated by the disposition to please God in the position and opportunity the Lord gives for service. Each one ought to so think of himself as to think soberly, according as God has dealt to each the measure of faith. All such are in the spirit the Bible calls "meekness," -- the spirit that is opposed to self-satisfaction, self-esteem, and desire of approval from others. The spirit of meekness is such that although our Heavenly Father desires each one of us to have of all the graces meekness is the most important. A preacher was once asked what the principal thing is, and he said "meekness;" he was asked what the second thing was, and his reply was, "meekness"; and again the third time and the reply was, "meekness." We believe that preacher gave the right answer to the question. There is nothing more necessary on our part in the sight of our Heavenly Father, if we would be useful, than to have meekness. There is nothing more certain to put us aside than the lack of meekness. God resisteth the proud, but giveth grace and favor to the humble. There is every reason that we should be humble. "Wherefore dost thou glory in anything thou hast received." In the presence of the Father we are beggars, we are naked, destitute of righteousness, wisdom, true love, and will-power that would make us like our Heavenly Father, and God knows, therefore, that we ought to be in a position of

meekness in His sight. More necessary is this from the standpoint of our Heavenly Father's estimate of greatness, when we contrast ourselves with our little opportunities and ability to the marvelous character of our Heavenly Father. Who are we that we should think anything of ourselves, but our sufficiency is of God who has made us able. When we look at the standpoint of the flesh, we have nothing of the flesh that would commend us to Him. From the standpoint of righteousness, all are standing within the goodness of God. We look upon it from a standpoint that makes us like God. It behooves us, therefore, dear brethren, to have such an estimate of ourselves as is humble. This ought to be cultivated. The Lord speaks of those who humble themselves and it is a process of cultivation. Think meek thoughts. Refrain from thinking such thoughts that would tend to our having the idea of our importance, ability or superiority. If pride is our fault, thinking on meek thoughts will help us more and more to become meek. Our usefulness in our Heavenly Father's cause will depend upon our being meek.

One of the great idolatries is that of wanting to be a mouthpiece of our Heavenly Father, wanting to represent His character to the world which nevertheless puts us in front of our Heavenly Father so that the sight of Him is obscured. His Word throws light upon His character which makes us acquainted with Him. We see Him with the mental eye, imagine that spirit in one who presents God's Word, and wants to attract attention away from God. Imagine the abominable character of such. It is vain glory. Paul says, "Such preach Christ for vain glory." We are simply like John, a voice. God is to shine, and we should be content to allow our Heavenly Father to shine. Those who have the proper spirit realize their lack, and that in Christ all goodness resides, and that God deigns to use them as mouthpieces, not to put their own vain imagination before God, but hold up the Father to the light, and therefore to the appreciation, admiration, love and adoration of those that look. Meekness, therefore, on the part of those that present God's Word is essential. No idolatry is greater than the idolatry that thrusts itself before others for adoration of their talents, and ideas.

Meekness is finally going to receive its reward. Humble yourselves under the mighty hand of God that He may exalt you in due time. Though we are disesteemed in the sight of men now, the time is coming when those who despise us now will have a different opinion of us. Isa. 60:15: "Whereas thou hast been forsaken and hated, so that no man went through thee, I will make thee an eternal excellency, a joy of many generations."

Isa. 66:5: "Hear the word of the Lord, ye that tremble at His word; your brethren that hated you, that cast you out for my name's sake, said, Let the Lord be glorified; but He shall appear to your joy, and they shall be ashamed."

## **Gentleness.**

BROTHER C. A. DANN, Toronto, Canada: I feel tonight with you, I am sure, that no more appropriate subject could be taken up, upon the near parting of the dear ones from each other, as we separate from this blessed convention which we have so much enjoyed, and it is my privilege to say a few words along the line of gentleness.

Our dear Brother Johnson pointed out what was the most important element in that attribute, and we think the most beautiful is gentleness. What fragrance is to the rose so gentleness is to love.

We realize that all through our experience as Christians, this characteristic of gentleness has permeated all of our Heavenly Father's dealings with us, and in the inspired Apostle Paul's statement regarding it we read, "We as ambassadors of Christ beseech you that you be reconciled to God." Not in a threatening way does our Heavenly Father draw us, but rather with entreaty. We are besought to be reconciled to God, and to accept what He has provided in the sacrifice of His dearly beloved Son. So, dear friends, all through the epistle we find these words frequently repeated, "I beseech you, brethren." After we have received this great favor which God holds out for us, justification, we again hear the words of entreaty through the Apostle: "I beseech you, brethren, receive not the grace of God in vain." Again we have the gentle entreaty further on as we come to know more and more of the Lord: "I beseech you, brethren, by the mercies of God, that ye present your bodies a living sacrifice." When accepting this we press on toward the mark and prize of our high calling. So we realize that in the age to come the same gentleness will be manifested. The most incorrigible of mankind will have at least one hundred years of this gentle treatment. This being the case, it behooves us to endeavor to cultivate, yea, a necessity that we should cultivate that quality of characteristic, for without this element it is practically impossible for us to do anything in the service of the Lord. The opposite quality of gentleness is uncouthness, roughness, abruptness. In the endeavor to present Present Truth, we would be unable to make any headway without gentleness. You will notice how this wonderful quality has been demonstrated through the wonderful helps that the Lord has presented through our dear brother, and his fellow-servants. The errors, if we are hungering and thirsting after righteousness, are gently drawn away and the truth is given to us in their place.

We realize that we are in the midst of a groaning creation, misery, pain, etc., requiring in us gentleness. We realize that gentle teaching and kind manners are necessary, and we should with kindness seek to apply the eye-salve with our gracious Heavenly Father's assistance so they may see, so we may be able to draw out some of the terrible thorns that have been pressing into the flesh of our dear ones who belong to the Lord -- wheat indeed, but who have not yet seen the truth. So, dear friends, we all desire to cultivate this characteristic, and I could not express any better way than our dear Brother Johnson expressed last evening, that taking hold of our Lord's Word we shall search the Scriptures and find so many passages showing our Father's gentleness, and how He deals with us, and then let us take a conscious hold upon these by the new will and work them out in our thoughts.

So, dear friends, realizing the necessity for this characteristic we trust we shall endeavor more and more to press on to attain to this gentleness which is so manifest in our Heavenly Father's character, and in that of His dear Son. We are glad to have the privilege of this convention, and have had the opportunity to cultivate this element while here, and trust we have done so to some extent.

## **Patience.**

BROTHER A. C. WISE: I have been placed on this program without any consultation, and I am not engaged much in addressing the public, but more from house to house on the great Plan.

This subject of patience is one that the Scriptures largely call attention to. We have had little opportunity at this convention to cultivate this element of patience, but it will be that, dear

friends, which will confront you in your Christian life. You will not in this convention have the privilege, but in the thousands of homes, in the domestic relations, etc., is where your patience will be tested -- not in a gathering like this. It is out on the battle-fields that you will be tested. In the camp the soldier will not be brought to the test. The Apostle said we will have to have patient endurance. He said to take the prophets as an example of patient endurance. We find the Apostle had to endure, and patience implies endurance of trial and suffering. And the Apostle said that suffering is that which the Christian will meet. Looking back over the history of true Christianity, we see that suffering has been a characteristic of the Christian's life. You remember when the Apostles were put in prison in the first period of the Christian age, and were brought out and scourged, they received it joyfully, rejoicing that they were accounted worthy to suffer affliction with Christ. This matter of patience is something that we will have to do with, and we must have a very large amount of patience if we understand what confronts the Christian church in the near future. The Apostle said, Let Patience have her perfect work. There is no one or class, perhaps, who will need as much patience as those that go out into the harvest work. An illustration from my own colporteur experience: One house at which I called, a lady kept me waiting a very long time, while she was dressing, and I did not know what my call would amount to, but finally she appeared and I sold her six volumes. Another illustration: When canvassing eleven years in this harvest work I could see very little result from my labors; we find, however, that we cannot estimate the value of our work, for in this convention my heart has been made glad as the result of my labors in the last eighteen years, many persons having come to me and said, You were the one that brought the truth to me; and my heart is made glad that now, when the harvest work is far spent and will doubtless close soon, I can see some who have been brought into the fold through the humble instrumentality of myself. "If we suffer with Him we shall also reign with Him." I trust, dear friends, that we will all cultivate this quality of patience.

### **Brotherly Kindness.**

BROTHER J. G. KUEHN, of Cleveland, Ohio: Brotherly kindness -- the sweet words, brotherly kindness. Not a hard matter at this time to know what brotherly kindness is; we have been living it today, yesterday and the day before. From the very beginning of this convention it has been, brotherly kindness, brotherly kindness. We can appreciate this the more because of the contrast which we meet when we are not together with those of like precious faith. We have been privileged, little by little, some for a few months, some for a year and some for a great number of years to develop this quality of brotherly kindness. But, dear friends, have we learned our lesson completely? Have we been able to practice this brotherly kindness to the extent we would like to practice it? Let us see for a moment; let us now in mind go back to our homes, to our home companions, and classes, and let each look into his heart. Have we been able to practice as much of this brotherly kindness at home with the brethren we meet every day, at least once or twice a week? Have we been seeking to cast flowers in their paths? Have we been praying to our Heavenly Father that we might have the wisdom and grace so that we would show this brotherly kindness in our every word, deed and act? Surely we have been trying and seeking to do this, but have we been doing it all the time? Has there not a time come up that a brother or sister or somebody else acted so queerly and we said: "Why can't he see it like I see it; he ought to see it." Or, "There is sister so and so, she takes a decided view on some point, and I cannot see why she sees it so and so." Have we been able to show our brotherly kindness to that sister? Perhaps we wanted to and perhaps we did not want to. Perhaps we were so sure we were right that we did not



consider the brotherly kindness. It seems that we are being tested along those lines, along the lines of brotherly kindness. We realize and understand that you and I do not speak alike; we do not walk alike, or write alike, and let us remember that we do not think alike. Let the thought be in our hearts and minds that the brother or sister is seeking to serve the Lord to the best of his or her ability.

Now then, if you and I differ, it is not a difference of heart or mind; it is a difference of brain capacity. We have a different way of arriving at a conclusion, and we may not be able to arrive at the same conclusion; but if we bear in mind that we are both working for the same Master, and have the same love dwelling in our hearts, we will exercise brotherly kindness. We have a Scripture which reads, "Be ye kind one to another, tender hearted, forgiving one another, even as God for Christ's sake forgave you." How much that means! We know that God looks upon us under Christ's Robe of righteousness as just or right. Now, if we are to forgive a brother and sister as God forgives us, it means that we would look upon a brother or sister as just, or right. Can we do it? Surely we will all try to do it. Quite a number of our dear friends are not permitted to be here with us at this convention. They said when we left, "God bless you." We prayed that God would bless us and use us in whatever way He saw fit. There is still a great opportunity for us when we go back home. Let us go back home with the same thought, to get a blessing and to give a blessing to the brethren that were not permitted to come with us, and we will find that in blessing them, we will be blessed. This matter of blessing others, of developing this in our hearts, this brotherly kindness, is a matter like all the other graces of growth in the Spirit.

## **Godliness.**

BROTHER L. W. JONES, Chicago, Ill.: The general topic for this evening is "Love." It is the sum of all the graces. Like the tire of a wheel, love binds all the elements together. Using a wheel as an illustration, the hub to represent faith, we are admonished in 2 Peter 1:5, 7, to add to our faith virtue, and to virtue knowledge, to knowledge temperance, and to temperance patience, and to patience Godliness, and to Godliness brotherly kindness, and to brotherly kindness charity (or love). These as spokes in this spiritual wheel are all bound together with the tire of love. This tire is round, and never ending. This wheel of love must have all the spokes or elements of love, or it will not be a perfect wheel; it will not be round. Now Godliness is one of the spokes as mentioned by Peter. This word godliness means Godlikeness, and no Christian character is complete without it; and like all the other graces, it must be cultivated. In First Timothy 3:16 we read, "Godliness is a great mystery; God was manifest in the flesh, justified in the spirit, seen of angels, preached unto the Gentiles, believed on in the world, received up into Glory." What a mystery this is to the world. How little God-likeness the poor world can see! But we thank God that our eyes have been opened, that the mystery has been made clear to us, and that we are permitted to cultivate this grace.

Again we read in Second Timothy 3:5, that some have the form of godliness, but deny the power thereof. We want to be Christians whose lives are powerful because of the godliness manifested in our daily walk. Again in Second Timothy 6:5, we read of some who suppose that gain is godliness. How many there are in the world today who are seeking again and think that in the possession of it they are made godly. In the very next verse, however, we are plainly taught that it is not gain that is godliness, but that godliness with contentment is great gain.

Referring again to the statement of Peter, where he admonishes us to add the various elements to our faith, he concludes by saying that if we do these things, we shall not be barren or unfruitful in the knowledge of our Lord Jesus, and that an abundant entrance shall be ministered unto us into His everlasting Kingdom.

## **WEDNESDAY, SEPTEMBER 4.**

### **Colporteur Day.**

All of the sessions of the convention on Wednesday were devoted especially to the interests of the Colporteurs. The morning session was taken up by addresses of several brethren, the afternoon being devoted to illustrations of successful methods of work and assignments of territory to new colporteurs, and the evening was devoted to a colporteur praise and testimony service.

At 10:30 a.m. Pilgrim Brother Sullivan addressed the convention as follows: Beloved co-laborers; I esteem it the greatest possible honor and privilege to be permitted this morning to speak a few words to you, with whom every throb of my heart is in sympathy, and to whom all the love of my heart goes out. I need not tell you this morning, dear brethren, and friends, that my heart is in sympathy with you. God knows. I know something of your conflicts and of your trials, and we are not to think it strange concerning the fiery trials that are to try us, as though some strange thing happened to us. It is happening to all of us. We are in this same narrow way together. I would like to comfort you concerning your faith if I could. We are called unto this very same thing. You must remember this, that the world is suffering, too; that some of them must suffer during the Millennium, even for a thousand years. Remember this, that your sufferings and mine are peculiar; they are intended to test our faith: It is our faith that is going to be rewarded. You and I, and all of us, are in the furnace now to be proven, to be tested, to be tried, to know whether we are bringing our lives into accord with our faith or not. Not many can do this. I would like to comfort you, as the Apostle says in I Thess. 3:2: He sent Timothy to comfort them concerning their faith, and in the fifth verse he says, "When I could no longer forbear, I sent to know your faith, lest by some means the tempter had tempted you, and our

labor be in vain." And he says in the 10th verse, "Night and day praying exceedingly that we might see your face, and might perfect that which is lacking in your faith."

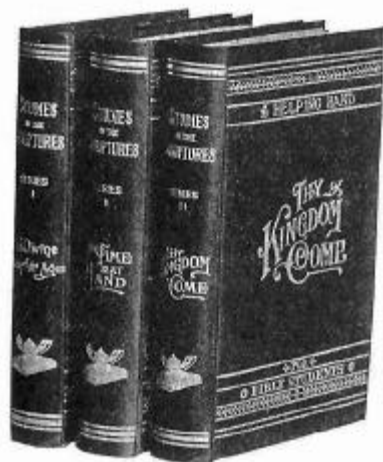

Is it true that in all the trials and afflictions and necessities, our blessed Heavenly Father is there looking on, and our blessed Lord is there looking on, listening to what we say, and seeing what things will control our actions, and seeing how we appreciate the opportunities of walking in this narrow way with our Lord? It is true, dear brethren, that we are living in His immediate presence, and it brings a holy awe into our hearts when we remember this; and not one is making any progress in the narrow way who does not realize it.

Again in Isaiah 35:3, we read: "Strengthen ye the weak hands, and confirm the feeble knees." I would like to strengthen some weak hands here this morning, because I know it would be the greatest delight of my soul to do this. I was here yesterday afternoon, and the thought that filled my mind was this: This is the hungriest crowd I have ever seen in my life. You were just fed, and fed, and fed; and you prove it this morning, after such a feast as that, to come here now to gather up some few little crumbs that may have fallen by the way. You are still hungry. This, dear brethren, shows that your digestion is good, and that you have gotten to a place now to where you can appreciate strong meat. I want to say to you that these hard experiences we are having are cheap at any cost. We are all imperfect, mentally, morally and physically. There is not a sound man or woman today on the face of the green earth. What a picture it is, everyone of us in some stage of death, and our poor race going to the tomb at the rate of ninety thousand a day! Now these hard experiences we are getting are cheap at any cost. Suppose you were heir to the throne of England, and that you were bitten by a poisonous reptile. Wouldn't you consider anything that would bring health, and restore you, cheap? That is exactly the condition. You are heir of all things, and here you are imperfect, and you have to be made ready for the work. This new mind has to be developed in us, and these experiences are intended to produce this very result in us. It is the Lord's blessing we all need, and not the human sympathy that we all so much crave. We must be able to recognize the Lord in His providences and in His Word, and in all the experiences in our lives recognize His hand leading us; and this craving so much for human appreciation and for human sympathy simply shows a want of appreciation of our blessed Lord. We must remember that our personality and our individuality have been swallowed up already, and I can see that there is a measure of unhappiness in those who are still trying to preserve their individuality. You must just allow yourself to be swept in, and drawn in, and become one with all the balance, and then you are happy, and it makes no difference whether you are alone, or have associations. All things are yours, and you are not alone.

There is one little thing I would like to impress upon your minds: We must avoid this martyr spirit, thinking that you are giving up a little thing here, and a little thing there, and the Lord ought to think more of you on account of it. When you lay down your life itself in the blessed service, it is just like giving up a penny for the whole earth. It is all grace, all favor. We must avoid this martyr spirit. It is the Lord's work, and no one can succeed in any part of it without His strength and blessing; no one can succeed in this work whose heart is not in it. It is the Lord's hand that is directing every minutia. It is His grace and favor by which we enjoy such an occasion as this. This meeting, to my mind, is one of the most wonderful miracles on earth; and we need just such experiences as we are getting here, we need the very polish that we are now receiving. I will say this to you: When you seek for your location, you should stop and consider and pray before you decide, and expect Him to guide you; and even when you get there, you should expect Him to direct you even to the location of your room; and expect Him to direct you in all the little affairs of the work. And in the morning of each day, you should remember that this is the Lord's work, and you are the Lord's servant today, and you are to do His work, in His way. You must do the right things, but you must do it at the right time and in the right way. These three things keep in mind: (1) There is but one way, and that is to seek to know His way. (2) There is but one time, and that is now, that is to occupy us. (3) There is but one thing to do, and that is to sow your seed in the morning, and withhold not your hand in the evening. Do not do a little now and imagine that is enough for all eternity. Keep pressing on closer, as though you expected to convert the whole world, although you know you will convert but very few, leaving

the whole result to Him; and it is the same thing to us, whether it is many or few; it is the Lord's work. These experiences are intended principally to benefit you. "Herein is the Father glorified that ye bear much fruit," -- not that you convert the world. These things will polish you; and I will tell you, dear brethren, I am always glad when I get to some place to hold meetings, and find out there are some colporteurs there. I feel doubly assured of the Lord's blessing at a place like that. The colporteurs should surely occupy the very front row of seats. I tell you it is a blessed service, and I tell you also that they are growing today as no other class is growing; they are developing as none others are developing; and I never see one the second time that I cannot tell he has grown since I saw him before. I am watching this very closely.

Now, suppose that in the place you are, you are not succeeding very well, what does the Lord say? He says, if they will not receive you in one place, in this city, flee to another. Don't flee from the work -- flee from the place! I want you to get that thought. You must not quit the work, you must quit the place. Take it for granted that He has a work for you to do elsewhere, and go to another place. Do not quit the work, quit the place. That is what it means; it means nothing else.

Another thing: You must not stall before you begin. When I was a boy, my father was a doctor, and a preacher, too, and he had a team; one was the largest horse I nearly ever saw, and the other was a little pony, and we had to work these two together. He would buy corn around in different places, and sometimes he would send me and another colored boy to haul this corn in, and we would have to use this team. We would get stalled nearly every time, and I was so afraid that I would be stalled before we got to the mudhole. I was sure we were going to stall, and sure enough we would. We would get into the mudhole, and the wagon would cut down deep into the mud, and we would whip the big horse, thinking he was big enough to pull us out, and we would not hit the little one at all. After a while the big horse would get tired of the whipping and he would make a great lunge and break the singletree; and we would all imagine that if the singletree had not broken, he would have carried it out that time. But that kind of pulling will never move a load. I have found out since that it takes steady work, that it takes humble work, that it takes the recognition of the Lord in this matter, and I will tell you, dear brethren, when we get in harmony with the Lord, we will succeed, and not before. We must find out that the flesh does not profit anything. Now, you must not stall before you begin. Do not be disheartened or discouraged before you get into the work. Trust the Lord.

Another thing: Do not try experiments. Not very long ago I was talking with a young brother who had just come to manhood's estate. I suppose he was about nineteen years of age. He was getting \$50 a month, and having his wages increased right along. He was a bookkeeper in a flouring mill. His mother was very anxious for him to give up his work and go into the colporteur service. I did not think he was quite ready to do this, and I told her that it was no profit to him to give up his position, unless he did it willingly. So I was walking along talking to him, and said: "Are you willing to sacrifice your job for Jesus' sake?" "Well," he said, "Brother Sullivan, if I could sell the books, I am perfectly willing to go into it." I said, "That is not the question. Are you willing to sacrifice your job for Jesus' sake? Are you willing to lay this job on the altar, even though you do not sell a book on earth, and trust Him for the result? Are you willing to do that?" I looked at him and the tears were going down his cheeks; his lips quivered and he could not say a word. I pulled down the curtain on the scene; I could not say a word. I could see it was the grandest opportunity of his life, if his faith could just take hold of these

things, and become real enough to him and valuable enough to him, for him to be willing to lay down these temporal things and sacrifice them for these unseen things. Not many can do this. Most of the world is like Esau. They cannot push away these things, which they know are good for the flesh, these human associations, things to be worn, eaten and changed; they cannot push aside this mess of pottage. It is only the Jacob class that is being sought now. You must not try experiments. You must go into this work to stay there, and die of starvation if necessary.

About a year ago I was taking with Brother Dickerson, who is one of the best colporteurs in the field, and he was talking about quitting work on account of rheumatism. I said, don't do it. You had just as well die of rheumatism as anything else; you have got to die anyhow. We had quite a talk about it. At the Indianapolis convention, I met Bro. Dickerson. He was the first one at the train as we stepped off. I said, "How are you?" And he said, "Never better." I said, "You do look well. How about that rheumatism?" He said "I just kept holding back and holding back thinking I would have to quit the work, and the rheumatism stuck to me. Finally I was determined I would continue in the work if I died of rheumatism, and that rheumatism left me and I haven't had a touch of it since." I tell you, dear brethren, it is after we stand the test that God sends the blessing. You must stand the test.

We must go into this work, and go into it to stay. It is only a few more years, a few more sorrows, and it is all over. When did the angels come to minister to our Lord Jesus Christ? After he had fasted 40 days and 40 nights, he was hungry, and now the Tempter came to Him and tried to get Him to use His power in a selfish manner to provide for His own physical necessities. Take your affairs in your own hands -- that is the proposition. You look out now for your own self. Make these stones bread. That will show that you are the Son of God, and at the same time, you will be ministering to your own physical necessities. Use your power in a selfish manner. Take your affairs into your own hands. And Jesus said, Get behind me Tempter; -- and then angels came and ministered unto Him. Oh, dear brethren, they will always come. But when do they come? Just before the temptation? No. Just after, when you have stood the test. I will tell you they are always there and the blessed Lord is looking on to see how you are standing these temptations. He says that if one member suffers, all the members suffer with it. There is a quotation in Acts 22:7, 8 that I wish to read: "And I fell unto the ground, and heard a voice saying unto me, Saul, Saul, why persecutest thou me?" Saul thought he was persecuting the Christians. Oh, just remember that when you touch one of these little ones, you are touching me; the very hairs of their heads are numbered. It is just one great sacrifice, and you are filling up that which is behind of the afflictions of Christ.

Now keep this in mind, the Lord can take care of us, and He only can do this. In Matt. 10:9, the Lord in sending out His disciples, said, "Provide neither gold, nor silver, nor brass in your purses, nor script for your journey, neither two coats, neither shoes, nor yet staves, for the workman is worthy of his meat." Now why did He send them out in this helpless, dependent manner? Do you know why? Look in Luke 22:35 and 36. Jesus said unto them, "When I sent you without purse, and script, and shoes, lacked ye anything? And they said, nothing. Then said He unto them, but now, he that hath a purse, let him take it, and likewise his script; and he that hath no sword, let him sell his garment and buy one." What does that mean? That when I sent you out without a thing in the world, did you lack anything? No. I took care of you then? Yes. Now you can take your purse along, and your script along. In other words, you can now do what you can

reasonably to take care of yourselves. But, do not depend on what you can do -- you depend on me. Did I not take care of you when you did not have anything? Yes. Well, I am going to take care of you now; carry your script and your purse along, but do not depend on them. You look to me, that is the lesson; I can take care of you. When I first started in the Pilgrim service, I had one hundred dollars, and I thought to myself, I had better take this hundred dollars along with me, I will get out of money somewhere and won't have enough to get home on. I carried that money with me until I got to Allegheny, and I found out I never was going to need it, so I put it in the tract fund. I have never needed it. The Lord does not have to have our money, and the fact is, He does not have to have any of us. It is the most exalted honor in this world to be permitted to be His disciple at all.

Now, then, I always think of the infant as doing well so long as it is growing. Now, the colporteurs are growing, and they are growing faster and faster. We are all infants together. We look now at a little child that has broken its doll, and its little heart is nearly broken; it is crying, and we look on and smile, and think, how foolish! And I want to tell you that some of these little things of human associations and human possessions that we so much appreciate today are the merest trifles, like that doll. When we get a little farther along, and are permitted to look back at them, we will do so with astonishment and wonder that we could place such a high estimation upon them. We are all infants; none of us live but thirty, forty, fifty or sixty years. The Bible speaks of an infant one hundred years old. So we are but mere infants, everyone of us, and these things are all light afflictions; they are very small things. We must look at the things that are not seen, and keep our eyes fastened on them continually.

Another thing we must remember is this: That all of our experiences are the Lord's private instructions to us, and we should be very careful how we relate them to others. They are private matters. You would not feel like you wanted to just unfold all of your private correspondence before the public. This is a private matter, and a very sacred matter between you and the Lord, and you should be very careful, especially how you relate any of your discouraging experiences; you might discourage somebody else. These things are intended to bring about a recognition between ourselves and the Lord. We must recognize Him. It is a very important thing. What we should do is to earnestly ask for wisdom that we may understand these things, and appreciate them, that we may see what lessons the Lord is trying to teach us.

I want you now to turn over in your minds for a few minutes the admonition of the Apostle Paul when he said for us to consider Him, who endured such contradiction of sinners against Himself, lest you be weary and faint in your minds. Think about the Lord Jesus Christ, an humble man, passing along in the world, and yourself now in comparison. The world thought He was a great fool; there He was, a man of sorrows, humbly passing along. Well, you are now following in His footsteps, or trying to do so. We look back today and think of that, and see what a great honor it is for us to endure a little for Jesus's sake, to walk in His footsteps. Oh, the importance of this work! Would to God that I could impress it upon you. Look at poor Moses. There he is, with a band of rebellious people, going through a wilderness country, and no doubt he was almost the greatest character in the world outside of our Lord Jesus Christ; and here you are, being made a spectacle unto men and unto angels, passing through the wilderness of sin. I do hope and pray God that you may properly consider these things. Isaiah 30:15: "In quietness and in confidence shall be your strength." May God bless and keep you, and help you. Let us keep our eyes fixed

on the goal, looking at the things that are not seen, and may God's blessing abide with you richly.

Pilgrim Brother P. S. L. Johnson then addressed the colporteurs as follows: Dear friends: I want to call your attention to a text in John 4:36: "He that reapeth, receiveth wages, and gathereth fruit, unto life eternal." In one hundred years from now Nicholas of Russia, Edward of England, William of Germany, Franz Joseph of Austria, and Roosevelt of the United States, will say, "Oh, if I could only have been a Millennial Dawn colporteur and volunteer; if I had only used my time, instead of trying to reform irreformable conditions, in seeking to spread the Word of our Heavenly Father, how happy and blessed would be my estate now." It is well to look upon ourselves sometimes as others will look upon us later on. I want to say this for the encouragement of our colporteurs and volunteer brethren; that later on we who have had an opportunity of spreading Present Truth will be the ones envied of the world, and that should inspire us with love and zeal in the interests of our Heavenly Father's cause.

We want to show some of the joys that come from service. Service gives us the opportunity of association with Christ in suffering; and in these particulars quite a number of thoughts come to our minds that will be helpful and stimulating to us in our daily lives, and in our service in behalf of our Heavenly Father's cause.

In the first place, we are used of the Lord in blessing others. To some, it is simply a word of comfort. This world is in need of comfort. The adversary by his blinding delusions has put a great many people under such stress of sorrow, and almost despair, that they need the balm of Gilead: "And the spirit of the Lord God is upon me; because the Lord has anointed me to preach good tidings unto the meek; He hath sent me to bind up the broken hearted." And this is the message that everyone of the Colporteurs are able, as a member of the Body of Christ, to apply to himself as showing his work. And how many a sad heart, groaning because of despair over one near and dear who has passed away, has been cheered, blessed and refreshed by a message to the contrary from one of those whom God sends forth, unknown and disallowed by men, but known and precious unto our Heavenly Father.

Then again: Our Heavenly Father grants that those who reap might see fruitage, in the way of those who come into the truth through their labors. This is not always the case. Sometimes brethren in the colporteur and volunteer work labor continuously for years without knowing of anyone who has been interested in the Lord's Word to the extent of coming into the truth through their labors; but on the other hand, there are some who are given the privilege. Our dear Brother Wise told us last night that he was almost in despair over the fact that he could see no one coming into the truth through what he had been saying, but when he came to this convention, he met one after another who said, you are the one who first interested me in the truth. We may not in this life be able to see those whom we have been privileged to interest in the Truth, but there is going to come a time when we will know it without fail beyond the veil; and when the Lord withholds that from us now, it is because He thinks it is for the best for us not to know it just now.

Then again, we not only help others in connection with the truth, but we want to say that the colporteurs especially have done a very important work in the way of preparing for the pilgrim service. We can talk from experience on this line in many cases, for we found on addressing the

public audiences someone would say after the service: Why, I bought a book from somebody, and there are so many things in that book just like you have been telling; and I ask what book it is, and they say; It is Millennial Dawn. So the colporteur and volunteer brethren help the pilgrims in their work, and thus make it easier for them to interest in the truth certain ones who are capable of being interested.

We want to call attention to a certain line of work in which some colporteurs have been industrious in connection with their own work. During our trip in the Northwest in this last year, it was our good fortune, under the Lord's providence, to come in contact with two colporteur brethren, and of all whom we met in the West, none gave us better help in a general way than these two brothers. They found out what was needed in order to attract the public to the meetings, and went to work with might and main in order to do that. It was largely due to their methods of advertising that we had larger audiences in the State of Washington on the part of the public than in any other part of the country. Not only those who were in Washington, but we have had colporteurs in Minnesota, and in Ohio, and Illinois, and Indiana, and Michigan, who have given us the same help. So we can bear up one another's arm -- each arm of the service helping the other.

Now we want to call attention to some of the blessings and rewards coming to the reapers in their personal lives and these we would talk on mainly this morning. Many are unable to see the external evidences of others coming into the truth through their labors, but God will richly and abundantly bless you when the labor is done from loving zeal and in meek humility.

Sometimes people go to California for their health, and one of the ways they spend their time, especially in southern California, is to walk along the beach trying to find moon-stones. As a rule, they do not find very many, but on account of the richness of the climate and the saltiness of the air, and the exercise, they find what they most desire -- they find health. And so, dear brethren, we are after the grains of wheat, and sometimes in the Lord's service we are unable to find these grains of wheat, but if in the Lord's spirit we do the work, whether as colporteurs, sharp-shooters, or volunteers, we may be certain that we will find what we are seeking -- a character fitted for the divine nature. And these are the points we now call your attention to.

In the first place, the first of the wages God gives us is fellowship with Himself; that is, partnership with Himself. He gives us the partnership of His spirit, an increasing measure of God's spirit of wisdom, justice, love and power. He gives us partnership in His thoughts, for it is to His servants that He gives to know the deeper things of His Word; and thus He takes us into confidence with Himself. He separates us from the rest of mankind and gives us things to know, which He would not tell to others, for He cannot confide in them.

Again, it gives us partnership in His care. He has a special care over the class that is using time and strength and zeal in His service. And it gives us a partnership in His love. That is a special love, dear brethren. So that from the standpoint of our partnership with God, we receive large wages in reaping.

Then it gives us fellowship with Christ in suffering. Suffering is not pleasant; our flesh shrinks from it, and yet there is a blessing in it under certain conditions. If we suffer as evil-doers, there



is no joy in that; if we suffer for righteousness' sake, rejoice inasmuch as you are partaking of the suffering of Christ. "If ye be reproached for the name of Christ, happy are ye; for the spirit of glory and of God resteth upon you." (1 Peter 1:14.) And we may have joy in suffering. How so? Because we love our Lord Jesus Christ. He is all in all to us; He is altogether lovely; and when we realize that we can put our lips to the same place where He had His, that we can taste the same disappointments, feel the same weariness, the fact that we can do it with Him sweetens the taste and makes our hearts overflow with joy. No privilege this side the veil, dear brethren, is greater than the privilege of being associated with such a noble character as the Lord Jesus Christ, in suffering from the same causes, in the same forms, in the same spirit, and for the same purpose.

Then it gives us an insight into His character such as nothing else we could think of would grant. How? It shows us what love under stress of self-denial is. We do not mean to say that we can come up to what our Lord Jesus has been privileged to attain in connection with our Heavenly Father's Word, but we do know that we are privileged, nevertheless, to see what was in His heart, and seeing this, we are enabled to gain a power for character development. Seeing that we are encompassed with such a cloud of witnesses, let us lay aside every weight, and the sin that doth so easily beset us, and run with patience the race that is set before us, looking unto Jesus. Dear brethren, we never can look better than when we see the heart that He had. How so? In order to realize what love is, we must experience love under the same conditions as Jesus experienced it, and showed it forth. And the justified do not do that; but with those who having consecrated themselves and have been sent out as harvesters in the Lord's harvest field, the matter is different. They are laying down their lives for the Lord; they are suffering with Him. They realize how hard it is to keep constantly in mind the thought of the privilege of suffering, the thought of love to God with all the heart, mind, soul and strength, and love to the Lord Jesus Christ like unto that of the Father, love to the brethren more than to self, so that one is willing to lay down life on behalf of the brethren; love to the world of mankind in pity for their fallen condition, and in hope for their uplift in the next age, the love of benevolence and beneficence to our enemies. Dear brethren, to exercise these amidst suffering, requires a will, a strength, a power of love, that the justified cannot realize, but that the consecrated as they lay down their lives unto death with Christ, are privileged to do. Not that we suffer to the same measure that He did. He had one hundred per cent of life, and we have less than one per cent that we lay down in the Lord's service. While He was laying down more than this ninety-nine per cent of life on our behalf, He touched experiences we do not have, and overcame conditions that we do not have; but when He came below ninety-nine per cent, He began to have experiences in the measure in which we do. And now, dear brethren, we feel, while laying down that much of life with Him, just as He felt, and we feel how hard it is to love under these circumstances, and we therefore realize as never before the love of Christ that passeth all understanding.

Then, again, dear brethren, he that reapeth receiveth wages in the sense that his heart is kept in the peace of God and in the joy of God. "Perfect peace have they whose hearts are stayed on thee." How can we have this peace amid trouble, and suffering and distress? We know that the world does not have it. There are two kinds of peace, the peace of the world and the peace of the children of God. "My peace give I unto you." The peace of the world comes from harmony with one's environment in earthly conditions; the peace of God comes, other things being equal, in being in harmony with our Father's cause. Take away the good things of the earthly one, and his

peace and joy are lost because his heart has been resting on these, and his foundation being removed, there is no basis any more for the peace of God. With the Lord's people it is different; their affections are set on things above where Christ also is, whose presence they also rejoice in, and whom to meet they look forward to with great joy. When these earthly things are taken away, as in the case of those, for example, who go into the colporteur work, they find they have not lost their treasure, and therefore their reason of peace and joy is not taken away from them. Our peace and joy will come in proportion as we sacrifice these things, which we have given to our Heavenly Father in the interest of His cause. Blessed is that servant who applies the sacrificial knife without stint to the throat of the goat until it is entirely consumed, and the more that is done with the heart fixed upon what we have above, the more the peace is, the more the joy is, because the more secure our hold is on those things. Therefore, he that reapeth receiveth a joy the world does not know, and is a peace that the world cannot give.

Then again, this life is one that is eminently helpful to us in developing a character that is needed for the overcomer. We who have consecrated ourselves, accepting our Heavenly Father's call to joint-heirship with Christ, aspire to be kings and priests. A remarkable office is this, indeed, for one thousand years. For one thousand years we are to deal with fallen, imperfect, sinful, blighted, ruined humanity, helping to life them up to the perfection from which Adam fell. To fill such an office with zeal and fruitfulness, it will be necessary for us to have certain qualifications indelibly wrought into our characters, and it is in the field of suffering with Christ, in loving service on behalf of God's plan, that this is done. And in this respect, he that reapeth receiveth wages.

We want to call attention to another reward that he who reaps receives: He receives all the blessings that God has promised the faithful overcomers.

(1) The sight of God. Oh, what a blessing. The Infinite Jehovah, we will be privileged to see at that time -- the God who loved us so unendingly that He gave the Son of His bosom on our behalf. We will see Him face to face. Jesus promises us that He will introduce us to our Heavenly Father. "He that confesseth me before men, will I also confess before my Father which is in heaven." Let us just think of the time when, if we are faithful, Jesus will take us by the hand and lead us to the Father, with some complimentary reference to our loyalty and fidelity in the interests of God's cause! Oh, the joy of that blessed hour, when in glory Christ and God I meet!

(2) Then, we will see Christ. "It hath not appeared what we shall be, but we know that when He appears we shall be like Him, for we shall see Him as He is." We love Him and we want to tell Him how we feel indebted to Him, not only as we do it now in prayer, and we know that He hears it, but face to face, eye to eye and mouth to mouth.

(3) Then, we want to see the brethren that have gone before, -- Paul, Peter, James, John, and the Saints of the dark ages, when the light of God's truth shone very dim. And then, those with whom we have been associated in the laying down of our lives. We want to greet all these and receive the new wine in the Kingdom with them.

(4) The divine nature, -- life in one's self, immortality; a body incapable of suffering of any kind; a body that will be a source of life to others. Unto us are given exceeding great and precious

promises, that by these we might become partakers of the divine nature.

(5) The marriage of the Lamb. Oh, what a husband! How proud the damsel feels, if she has a good disposition, and a good heart, if she has won an honorable husband. Oh, how the Bride of Christ will feel, when she shall be united with the noblest of the noble, reigning with Him a thousand years to help our poor race, now bone of our bone, flesh of our flesh, cursed by sin, blighted by the fall. These, we want to be privileged to uplift and bless in the interests of the Lord's cause. That will be one of the privileges of the reapers of this time.

(6) And then, what may come afterwards? We know God's method has always been to give larger things, to keep the best for the last, and so on in the succession of the ages which shall come, each age will bring to our experiences, if we are faithful overcomers, new and greater things than those that we now look for.

### **What shall we say to the things?**

Go labor on, and spending, be spent;  
Thy joy to do the Father's will.  
This is the way the Master went,  
Shall not the servant tread it still?

Go labor on; it is not for want,  
Thy earthly loss is heavenly gain.  
Men love thee? Heed them, praise them not;  
The Master praises. What are men?

Toil on, and in thy toil rejoice;  
After toil comes rest, after exile home.  
Now dost thou hear the Bridegroom's voice  
The midnight peal, behold I've come.  
Amen.

### **Brother James H. Cole**

Brother James H. Cole then addressed the convention in part as follows: I think in going into the colporteur work, it is well to follow the Lord's instructions, and the example He gave us in going out two by two. You know, as the saying goes, two is company and three are a crowd. And so, a crowd is hard to handle; they get in each other's way and use up time needlessly which we could use to better advantage. Of course I do not refer to having more than two in one city, but rather in one room.

In canvassing a person, you will meet many objections. Sometimes they will say, I haven't time to listen to you, I am just putting my baby to sleep, or I am in the washtub, etc. Don't pay any attention to those objections. They have no idea what you have. They think you are a book agent, or some other kind of an agent that is going to bother them for fifteen minutes or half an hour.

But, when they say no, I haven't time, don't pay any attention to that, but say what you have to say in a kindly way, and they will not be offended at it. Go on with your introduction as quickly as you can and you will overcome the objections, and they will forget all about their not having time. I do not usually enter the house if I can help it, I try to stay outside. When they invite me to come in, I thank them and tell them that I do not desire to detain them so long.

I think that it would be a great help to us if we would allow others to criticize our canvasses. Go out with your partner and let one canvass while the other criticizes. I think we are all too timid, we do not like to allow anybody to hear us canvass. We want to overcome that timidity. On one occasion, I went out with a lady, and criticized her work about as follows: I told her she had gotten in a rut. She was not having very good success and had become rather indifferent to her work, and therefore did not put the energy into it that she should. When she would talk to a person, she would look up and down the street once or twice, and she should not do that. Do not take your eyes off a person for a moment except two or three times, maybe, when you want to refer to the references in the book. Always look the person square in the eyes, no matter whether he is looking at you or not.

Sometimes she would get a little nervous -- nervousness she would not realize; perhaps she would look at her fingers once in a while, or make some motion unconsciously.

And then she looked back and forth from the book to the prospective customer too much; she kept her eyes going back and forth very frequently. That makes the person nervous to whom you are talking. You should look at them steadily and only occasionally at the book.

Then she got in a habit of talking when too far away. You want to get close to the person and talk in a warm, confidential, interesting way, like you were really interested deeply in the work. The tone of her voice was sort of a monotone. Now you must raise and lower your voice; make some inflection. Do not talk along in a stream, but emphasize, just like if you were in a conversation, and interested in what you were saying.

Then another bad fault as I looked at it was this: She would say, this book is doing so much good, and you will get a great deal of help out of it. People do not like to be told they need to have some good done to them. Allow them to infer that for themselves; they will apply it.

Let us not forget the spiritual part. Before going out into the work each morning, let us pray about the matter, and not depend on our own strength to sell these books.

### **Brother Hutchinson**

Brother Hutchinson then spoke in substance as follows:

Dear friends: One thing I have found to be most helpful in canvassing is to be pleasant. It is one thing to be courteous and another thing to be pleasant. To be courteous is to be agreeable and polite; you are all that, I have no doubt. But it is quite another thing to be pleasant. The colporteur should be agreeable. He should agree as far as possible with the person whom he meets, and that is a very easy matter to do in most cases.

In canvassing foreigners, we find it pays to be very pleasant with them. A smile will go further, for instance, with an Italian, probably, than a whole hour's talk would. We find just a few words and a pleasant smile will get an order quicker than going through an ordinary canvass.

Some canvassers take candy in their pockets to give to the children. We do not do that, but we have found that sometimes the small mottoes which cost two cents apiece have often helped in making a sale. For instance the person being canvassed would be undecided whether to give the order or not, and we have seen the little one playing around, and just handed it a small motto; that has succeeded in bringing the order in where otherwise it would have been lost.

Do not ask for the order if you can possibly help it. Get the order without asking for it. It is often easy at the end of your canvass to pause a moment, and if they want the book they will say so. But do not wait but a second, and then go on with something else. That leaves them in a position where they are anxious to get the work. During the recent shortage of books we had quite a number of people come to us thinking they had been over-looked and they were in such an attitude they wished them, and were not in any way disposed to cancel their order on account of the shortage.

Another thing will be helpful to you in your work. When you go home take your order book and write out on a separate sheet of paper all the orders you have taken that day. For example, usually we take orders for two or three different days; we might have a date set for the 10th, one for the 17th, and one for the 24th. Now the plan is to get a large sheet of paper and write at the head of the sheet the 10th; then the full name and address, and number of books sold to the person for delivery on that date; get another sheet of paper for the 17th, and do the same with that, until you have the whole of your orders entered up systematically. That will save you a great deal of time. When you come to deliver you have nothing to do but go to the sheets, the top sheet first, instead of having to hunt through a long list of orders for different days. Again, if you do that, in case the order book should be lost it would not make much difference. The motto is obvious: you should not carry all your eggs in one basket.

I would say that it is well for all colporteurs to learn how to deliver. If you take orders and do not deliver them, it does not make a very good showing. In the beginning I had considerable trouble along that line. People would say I cannot take them, but I will do so next week, and I would say, I will be glad to come then. But if you do that, they will want you to be coming every week. It is well to take no notice of their refusal but to go right on delivering the goods, saying, "I am sure you will enjoy them very much indeed; everybody is pleased with them, and I know you will appreciate them very much." And very often people would go and get the money, when they said they hadn't any. I would like to emphasize in closing that our influence upon people goes a great ways. And we want to leave a good impression with all the people we can.

### **Brother Boehmer**

Brother Boehmer then addressed the convention as follows:

Dear friends: After listening to all the other brethren, have said, I hardly feel I can add very

much.

We are not all constituted alike, and perhaps the way I would approach people would not be a wise way for some of the rest of you to approach them. But I conduct myself along the lines mentioned in hints to colporteurs, that is to be polite, and gentle, especially in introducing myself. I act a little hesitatingly at first, and then after I am through with the introduction I speak faster and very positive. I endeavor to make an impression and put emphasis on each word. I use my hands very freely. I find that is one good way. I have tried both ways. I have tried just to hold the book open and look at the party I am speaking to, but I find it not nearly as effective as when I make motions with my hands indicating the subject. For instance, speaking of the permission of evil and its results, and the necessity of restitution. Then in speaking of the heathen question I think it is very important, in speaking of the fact that nine-tenths of the human race have not been enlightened with the gospel, that our face should be grave. Let the party feel that we mean what we say, then lead them in spirit, as it were, to brighter scenes, where we see the wonderful hope set before us, and how all of God's purposes will be accomplished, and His promises fulfilled.

I have found no difficulty in getting orders, but my difficulty has been in holding orders, or in other words, delivering the orders I have taken. So I have found a good plan is to use these little mottoes. After I have taken an order from the party then I say, "As a little token of the order you have given me, I will present you this motto," and then make some little comment on the verse that is on there, "God is love," or "God is light," or "Walk in the light," saying, "If we would always remember that, how happy our lives would be." And they usually nod assent. I say, "Now hang that up. Here is the date of delivery, I will mark it on there so you will always remember it when you get these wonderful books." Then I leave them in a good state of mind, and it usually pays. Sometimes they will say, why Mrs. So and So lives over there, go and tell her I sent you. So that puts me on a social footing with them which I would not otherwise enjoy, and I have much better success in delivering the books.

I think it is well to be brief. I use the method, but I think I have abbreviated it to some extent. I do not care to spend more than about three to four minutes at a house. If I have not gotten an order, then I know I will fail even if I staid there an hour, because I had not made a vivid enough impression of the work.

## **7:30 P.M. -- Colporteur Praise and Testimony Service.**

The services of the evening were conducted by Brother Frank Sherman. His opening remarks were as follows: "Where the carcass is, there will the eagles be gathered together." Carcass carries the thought of an abundance of food. That is what the Lord said would characterize these last days.

Then the thought of eagles has been impressed upon my mind. They are far-sighted birds, and so it has been with the birds that have flocked here to this feast the past few days. They have been looking into the next few years and see what the world is not able to see. In the 91st Psalm we read, "He will deliver thee from the snare of the fowler." I am reminded of an illustration, in one of Brother Barton's discourses, of a dog on the ground and a bird up in a tree. The bird said, I see

fresh trees, rivers and green fields. The dog said, I think you are telling me lies, and if I could get you down here I would bite your head off. So it is with those who cannot see -- those who do not have this far sight.

In the 126th Psalm we read, "They that sow in tears shall reap in joy. He that goeth forth and weepeth, bearing precious seed, shall doubtless come again with rejoicing, bringing his sheaves with him." We are glad to have some sheaves, something to show for the labor and tears that are necessary in sowing this seed.

Opportunity was then given for a number to give their testimonies.

Brother A. N. Martin of Nova Scotia: I came quite a little way to be able to be here and hear your words, but I have been many times repaid up to the present time. My desire in coming was not only for my own benefit, but to take back with me some measure of the blessings to the friends I left behind, and as we are all members of the one body I am sure it is the desire of each one here that all should be blessed. We have some peculiar experiences in the colporteur work. Mine have been that, from the circumstances that come to me that seem to be the most discouraging; but these are the circumstances that generally bring us the best results. I have at different times run across those that are leaders in Babylon, and at one time one threatened to have me arrested, but he did not have the power just yet, and I have generally found that when they tried to hinder the work there was some one there who wanted to get the books. We should rejoice more and more in the word, for when we fall into diverse trials, then we should rejoice.

Brother Aug. Kreuger, Chicago: We have been engaged in the colporteur work for perhaps three months, and I am absolutely certain that it was the Lord that drove me into it. It was not because I was so willing to go, but because the Lord saw fit to give me the trials and tribulations. We have been figuring for two and a half years how we could get to a convention; the Lord put me into the colporteur work, and now I have been able to attend this convention.

I canvassed one whole afternoon, three hours, and never took an order for a book. I then crossed over to the other side of the street and the very first person was interested and he was a preacher. The next morning I was working in the same neighborhood and heard some one walking up behind me, and looking around, some one gave me a hearty shake and asked if I did not know him, and I recognized this same minister. Well, how are you doing? he asked. Very well this morning, I replied; they seem to be Christian people in this neighborhood. He said, Well, I am glad to hear that. Everyone you come to, I wish you would use my name in recommending this book. I did use his name and sold a great many books. I recognize in that the Lord's leading. The Lord is leading all the colporteurs and all these experiences are from the Lord and are for our good.

Sister Esther Kuehn: A year ago this summer I was at the Bible House, and when they were making the badges I wished I might be a colporteur. I am glad to say that I am now one.

Brother Walter McNaught: I have attended three conventions and never said a word. I have been afraid of the people's houses, but it has taken more courage for me to speak here. I want to be a colporteur as long as there is such a thing.

Brother Wm. Krueger: I have lost my home as well as my nationality. I rejoice in the work. If any one is not satisfied with their growth in grace and in the spirit, the best thing is to get into the colporteur work. There you can grow in two things: patience and love for your enemies. Patience in delivering your books. The Lord has richly blessed me. Not by taking large numbers of orders for books, but I have done fairly well. I find that the day that I do the poorest, I will find somebody that is deeply interested -- perhaps have read a volume. I always think of one text: "We both labor and suffer reproach because we trust in the living God."

A Brother: I have not sold so very many books. The Lord forced me into the work. Before the Cleveland convention I was in the building and loan business, but the doctor said I must get into outside work. I was permitted to go back to work when the weather was not suitable for me to canvass. My employer said he would give me a job because these Millennial Dawn people are good people and can be trusted.

Brother and Sister Geo. Draper then sang a song appropriate for the colporteurs, entitled "Fullness of Joy":

'Tis sweet in the presence of Jesus to dwell,  
Though troubles and trials annoy,  
To constantly feel His approval and smiles:  
In this there is fullness of joy.

Abundantly furnished with grace for our needs,  
When Satan attempts to decoy  
Christ flies to our rescue -- to victory leads:  
In this there is fullness of joy.

To work for the Lord is a privilege rare,  
Each moment of time to employ;  
Co-reapers with Him in the harvest to share:  
In this there is fullness of joy.

O glorious prospect, if faithful to death  
Of bliss that no foe can destroy!  
Made one with the Bridegroom, all nations to bless:  
In this there is fullness of joy.

(Chorus)

Fullness of joy! yes, fullness of joy!  
Serving the Master with hearts full of joy!  
Soon we will finish our work here below,  
With fullness of joy unto Him we shall go!

Brother E. J. Wood, Alabama: This is the second convention I have been privileged to attend. I have been in the colporteur work for one year. I began last fall in the country districts, and to my



surprise I sold 700 volumes in two months. This was a grand surprise to me; I had no idea that I would sell enough to pay my expenses, but I have been able to continue in the work. Since then I have sold three thousand volumes in towns in northern Alabama. To-night I am rejoicing in present truth. I am overflowing with thanks to my Heavenly Father for this wonderful privilege. I want to continue in the work to the end.

A Sister: I have been in the work but a short time. I am glad it does not depend upon the number of books that we sell. We have a chance to learn patience. A short time ago I met a lady evangelist. She said among other things, "God has not waited all down the ages, among these doctors of divinity, until a man like Mr. Russell came to the front." Here, instead of saying anything in return, I smiled and just pitied her for her blindness. We have many opportunities to cultivate patience. I cannot report 3,000 volumes sold, but I can say that I have sold over three hundred a year.

Aunt Nancy (Sister Campbell, Wilmington, Ill.): I hardly feel worthy to speak, but I do feel delighted to feel that the Lord has given me the privilege of going into the harvest field. I have only my own little town for territory, but I hope to gather a few grains of wheat. "My people shall be willing in the day of my power." Some are willing to help and others are willing to be helped. I thank Him for the privilege of being here; it is my second convention. I hope to do better.

A Sister: I rise to testify for others. I want to bring out a feature not mentioned at this convention, namely: the work of the colporteurs in starting little classes or ecclesias. A year ago four colporteurs came to Stamford, and while there started an ecclesia, and it is now flourishing with fourteen members. One is giving all his time to the work and I am giving a little.

Some have said to-day that they had been forced into the work. Well, ever since I got the truth I prayed the Lord to send laborers into the harvest, and so that is the reason you have been sent in. Others need not be surprised if the Lord sends them in also, for I shall continue to pray.

Another brother or sister testified that two colporteurs came to their town and started a class and now there were eighteen fully interested.

A Sister: Four years ago this month my husband and I were hungering and thirsting for something and a colporteur came to us and sold us the books, but when he came to deliver them we hid ourselves, although we saw him coming. Finally after coming three times we told him we did not want the books and said we would pay him for his trouble, but he canvassed us again and we finally took the books. In a short time we were interested and soon had our farm sold and we are ourselves now in the colporteur work. I urge you to not give up trying to deliver your books.

As a concluding feature of the services of the convention, at the close of the Colporteur Praise and Testimony Meeting, an opportunity was given each of the Pilgrim brethren present to give their testimony.

Some of the principal thoughts brought out in these testimonies were as follows:

One brother suggested that Satan has probably been looking on during all of this convention, but that he had not much influence here, for we have been too strong for him. But look out when you get away by yourself, when you get away in your fields, or in your work shop; he will have it in for you with all the force that he will be able to muster; but do not be discouraged or downcast, but continue to have faith in God and the victory will be yours.

One brother spoke of how we are engaged in a battle, and said that this Scripture impressed him most, "Bear ye one another's burdens and thus fulfill the law of Christ."

Another brother said that his testimony was an expression of joy.

Another brother said this convention had been the supreme pleasure of his life, and that he found it very difficult to be moderate in his joy. That this convention to him was a proof of the presence of the Lord. For surely none but the Lord Himself could provide just the things we all need as He has done in this convention. That we have needed just the polishing and help we are getting here, that we could not get in any other way. That this convention is a wonderful miracle, and should not be passed over lightly by any one of us. Right here the poor of this earth, but rich in faith, have been enjoying what the rich have never enjoyed -- the best there is in nature and at the same time from the table of the Lord. We are enjoying the good things from the Lord and the things of earth in a way in which the rich people of this earth never have enjoyed them. It has been indeed a foretaste of heaven.

Brother Williamson in closing the testimony meeting said that the same ones would never all meet again on this side the veil as we have met here in this last week; that we would not all meet together again until we meet in the great convention beyond the veil. That since the convention in Niagara two years ago some have entered the blessings and joys which the Lord had provided for them because of their faithfulness. But because of the friends on the other side, we have a closer and richer conception of what that Kingdom is than we otherwise could have.

Brother Williamson said in closing: "Now, dear friends, I want to leave with you the closing message of the convention, the Apostle Peter's words in the second epistle 1st chapter, 'Grace and peace be multiplied unto you through the knowledge of God, and of Jesus our Lord. According as His divine power hath given unto us all things that pertain unto life and Godliness, through the knowledge of Him that hath called us to glory and virtue: Whereby are given unto us exceeding great and precious promises: that by these ye might be partakers of the divine nature, having escaped the corruption that is in the world through lust. And besides this, giving all diligence, add to your faith virtue; and to virtue knowledge; and to knowledge temperance; and to temperance patience; and to patience Godliness; and to Godliness brotherly kindness, and to brotherly kindness love. For if these things be in you and abound, they make you that ye shall neither be barren nor unfruitful in the knowledge of our Lord Jesus Christ.'"

May God give us comfort and strength that we may be able to do what is His will and ultimately, according to that glorious grace, be ushered into the Kingdom according to His promise.

## **Testimony of the Natural Food Company's Officers. Presented to the Convention.**

BROTHER WILLIAMSON: In this connection, I would like to call attention to the kindness and hospitality evidenced by the people of the Natural Food Company, who have so kindly given us the use of their building. One of the officers of the Natural Food Company, Major Butler, called me up on the telephone, previous to this evening's meeting and said: "I want to tell you, on behalf of our company, that it has afforded us the greatest pleasure to have had with us your great convention, which is the largest ever held in this city. The influence of so many happy people, with their smiling faces, evident sincerity, earnestness and zeal for what they believe to be right, has been greater than I can express. To see so many people who really believe what they say, and who practice what they preach, has been a revelation to us. I never saw anything like it before. While we have tried to do all we could for your convenience and comfort, and to make your stay here a pleasant and profitable one, yet you have done more for us than we could possibly have done for you."

I think, dear friends, that this is a splendid testimony to the love of God shining forth in our hearts, and in our faces, and in our walk, and in our conversation.

Pilgrim Brother John Harrison: Brother Chairman, I move you that this convention, by a rising vote, extend our thanks to the proprietors of this building.

After being duly seconded, Brother Harrison's motion was put to the Convention by the Chairman, and carried unanimously.

### **THURSDAY, SEPTEMBER 5.**

This day was given to informal social interchanges, the convention proper having closed the day before.

It was thought that the friends would get together in groups and visit and go sightseeing, but notwithstanding every day of the convention had been full of meetings, the friends were still hungry, and instead of visiting they arranged among themselves for three more meetings, morning, afternoon and evening, which were addressed by Pilgrim Brothers George Draper, O. L. Sullivan and P. S. L. Johnson.

There was one party, however, that attempted to go sightseeing, but the Lord works in a mysterious way His wonders to perform; for, soon after starting for Goat Island with our dear Brother Fred Williamson to view the rapids and falls (he had been so busy with the affairs of the convention that he had hardly taken time to eat), it began to rain and we all sought shelter in the Pavilion. We soon had Brother Fred busy telling us about his experiences in the truth, about the Bible House and the work in general. Such close attention was given to what he was saying that many strangers, who had also found shelter under the pavilion, came near to see what was so interesting to us. Noting their interest, the hint was given to Brother Fred, and he was requested to tell us something about the Plan of the Ages, which he did by giving a half or three-quarters of

an hour clear presentation of the Plan. At the conclusion, we had opportunity to give out a number of tracts and to have personal talks with some of the strangers, and we trust some of the effort will bring forth fruit. It did us good, at any rate.

The three discourses given by the Pilgrim Brethren in the Auditorium of the Natural Food Company were well attended and the friends were highly pleased to have so much more than was planned for them in the program.

Thus closed the most wonderful convention ever held, up to that time, and all felt like saying, "My cup runneth over."

(Imagine yourself ready for the Convention, and mentally take the trip with us.)

All Believers in the "Ransom For All" Will Be Cordially Welcomed.

# **BIBLE STUDENTS' CONVENTION**

The Armory Hall  
City Hall Avenue

**NORFOLK, VIRGINIA**  
SEPTEMBER 29 - OCTOBER 6, 1907

Under Auspices of  
**Watch Tower Bible and Tract Society's**  
ALLEGHENY, PA

## His Way the Very Best

*(Composed by a pilgrim brother in his desire to comfort a sister  
who was denied the much coveted privilege of attending a convention.)*

How oft I've planned and hoped thereby,  
Some cherished wish to gratify;  
When He who knows far more than I  
Has snatched hope's star from out my sky.  
But well I know His reason's wise  
Whene'er He brings my plans to naught.  
He knoweth sure, I but surmise  
Which way is best; which ill had wrought.

Sometimes for ease my soul could sigh,  
Desires for peace to satisfy,  
But He who knows far more than I  
These longings too would crucify.  
And well I know His reason's right,  
Which adds this weight unto my cross;  
He could have made my burden light,  
And would, had it not meant my loss.

As eagles to the food would fly  
Saints gather in Convention nigh,  
Yet He who knows far more than I  
Has caged me so I cannot fly.  
Still, well I know His reason's good  
That locks the door to such a feast;  
For while I reason of what's good,  
He orders for the very best.

My heart has yearned to loudly cry  
The praises of my King on High;  
While He who knows far more than I  
Would even this to me deny.  
Right well I know His reason's grand  
Which shatters even this delight,  
That grants me to look on and stand  
Where faith and love would rather fight.

I bid fear leave; self mortify;  
And then my heart I sanctify  
For Him who knows far more than I,  
Upon whose grace I can rely.  
Yea, well I know His reason's wed  
To all that love divine would say.  
For I see but a step ahead,  
My Lord, to the end of the way.

## NOTES

ON THE SERMONS, INCIDENTS AND CIRCUMSTANCES CONNECTED  
WITH CONVENTION OF  
**THE WATCH TOWER BIBLE AND TRACT SOCIETY**  
*HELD AT NORFOLK, VA., SEPTEMBER 29 - OCTOBER 6, 1907.*



On September 26th at 5 p.m., a party of 37 left Chicago over the Baltimore & Ohio Railroad, enroute for the Convention to be held at Norfolk. About 20 of the party were from the Chicago Class; the others being from Clay Center, Kan., Pana, Ill., St. Louis, Mo., Crete, Ill., and Wilmington, Ill.

We arrived in Pittsburgh Friday morning about 8 o'clock. Eight of the party went on to Washington, but the other 29 stopped over and were met at the depot by our dear Brother Fred Williamson. After cordial greetings all around, he escorted us to a restaurant in Pittsburg where our old bodies were refreshed and strengthened with temporal food. We then took a car for Allegheny. On reaching Arch street, Brother Fred took us down the street on the opposite side from the Bible House. The friends were not aware we were near the Bible House until almost opposite, and then -- "There it is!" "I see it," etc. Then, after taking a good look at its exterior, we marched across the street and entered the building, more dear to those of "Like precious faith" than any other building in the world.

A number of the Bible House Family had left for the Convention just before we arrived, but some were still there and we were soon greeted by Bro. Van Amburgh, Bro. A. E. Williamson, Sister Taylor, Sisters Alice and May Land, Sisters Laura and Emma Whitehouse, Brothers Lewis, Sherer, Roller, Hoskins, Walters, Sister Bourquin and several others. The friends were soon busy making purchases of motto cards, bibles, etc.

The chapel was thrown open for our use, and we were given the liberties of the building. When the friends were through making purchases, Bro. Fred divided the party into groups and took us through the building, explaining the work as it is carried on in the various departments, and pointing out where the various members of the Bible House force sat. We also made a trip to the basement where the freight orders are handled and the stock of supplies kept. We also took a look into "hades." That is so designated because it is a dark room and in it is kept the reserve supply of "hell" Towers.

## Arrangement of Bible House.

First Floor: On entering the door to the right you find on the right hand the Store, for local sales. A show-case is full of motto cards, etc., and back of that are shelves full of Bibles, Hymn Books, Heavenly Mannas, etc. This department is in charge of Bro. Burgess. At the left side of the room are the desks of Bro. A. E. Williamson, Sister Taylor and Bro. Van Amburgh.

The show-case and desks occupy about a third of this floor; back of them is Bro. Russell's private office where he can be found at certain hours only. In this office are also the desks of two or three of his special assistants.

Back of this office is the mail and express shipping room.



That front part of the building entered by the street door shown at left of picture is used for office purposes, while the rear half is for the addressing, folding and mailing of Towers.

The basement is used for freight shipping and stock rooms.

Second Floor: On this floor are two rooms occupied as sleeping rooms by a number of brothers.

Another large room is used for the colporteur work.

There is still another room on this floor -- the Composing Room, in charge of Bro. Fred Williamson. In this room the type for the Towers is set up, although no printing is done in the building.

Third Floor: On this floor is the chapel seating about 300. It has comfortable folding seats, carpet on the floor and many beautifully painted texts of Scripture on the walls.

Fourth Floor: This is the Home proper of the Bible House Family. On this floor are the Sitting Room, Dining Room, Bro. Russell's Study and Bedroom, and also Bedrooms of a number of others. The window at the top of the spiral firescape is in Bro. Russell's Study.



## **Received by Brother Russell.**

We were instructed to be in the parlor on the fourth floor at 12 o'clock, at which time Brother Russell would meet us, as he was too busy during the forenoon. Promptly at 12 o'clock he appeared, and once more we had the pleasure and privilege of personally greeting "That Servant." We were then invited to the dining room, just off the parlor, and the entire company sat at the one table, thirty in all. The members of the Bible House Family served. The meal was made doubly enjoyable because of a number of interesting questions which were passed around and discussed. The afternoon was spent in social interchanges, some helping with the work, etc. At 6 o'clock we again assembled at the same table and partook of the evening meal, at which time other questions were discussed. Brother Russell informed us that if we urged him some, he might go with our party to Washington, where we expected to meet those who had gone on before. We were not slow in urging, and we found he had already purchased his ticket for our train. Brother A. E. Williamson escorted us to the station, and at 9:30 we boarded the train for Washington, D.C.

## **Join Other Friends.**

After an uneventful journey we reached Washington about seven o'clock and proceeded at once to the wharf where the steamer Montauk was waiting, and together with about one hundred and fifty friends from Washington, Allegheny, Baltimore, Annapolis, and other nearby places, started by water down the Potomac River and Chesapeake Bay for Norfolk. It was a beautiful and enjoyable trip in many ways. Soon after starting we had an interesting experience. Another steamer, the Jamestown, belonging to a rival line, also had on board some of the truth friends; it soon came along side the Montauk, and for a short distance the tow boats raced, but the Montauk could not keep up and we were soon left far behind. On the trip we passed many of the places of historic interest, because of the part they played in the Civil War. These, however, had small interest for us compared with the Convention towards which we were journeying. Just before reaching Norfolk, we came in view of some beautiful electrical illuminations and upon inquiry found they were from the Jamestown Exposition. The nearer we approached the more beautiful they appeared. This view is probably the most beautiful feature of the Exposition. At about 9:30 we arrived at Norfolk and were greeted by quite a large committee of the waiting friends, and escorted to the Armory Hall where the Convention was to be held. We secured assignments and proceeded at once to find our accommodations.



Mrs. U. G. Munsell  
Born 1876.  
Passed 1st Vail, 1903.  
Passed 2nd Vail, Sept. 38, 1907.

Mrs. Florence Ida Holmes  
Born Sept. 23, 1869.  
Passed 1st Vail, 1904.  
Passed 2nd Vail, Sept. 28, 1907.

On arrival at Norfolk, we were informed of the death two hours before of two of the colporteur sisters, Mrs. U. G. Munsell, and Mrs. Henry Holmes, of Springfield, Mass. These dear sisters had come with their husbands to attend the Convention. The four were on their way back to the wharf to meet some of the incoming friends; the sisters preceding the husbands about ten minutes. Just before reaching the wharf, a switch engine hauling some freight cars backed down on them and crushed out their lives. It occurred at about 7:30 p.m., and in the gathering dusk and drizzling rain, the sisters failed to see the engine which, in violation of the city ordinance, was backing across the street without lights, bell, or flagman, and silently bore down upon them.

This, from the standpoint of the world, was a terrible accident, but all the dear friends realized that it was an act of Providence, and that God in His great wisdom had permitted them to finish their course in that manner. We realized that they were then with us at the Norfolk Convention in a greater sense than we were who were left on this side of the vail.

The more we thought of it, the more we rejoiced over the fact that the sisters had joined those who had gone before, and this caused us to see how thin the vail really was and, inasmuch as we too had consecrated ourselves unto death, not to 1915 or any other set time, but unto death, we might be the next ones to join our dear Lord and the other members of the Little Flock.

While we rejoiced with the dear sisters on having finished their course, all our hearts went out in sympathy for Brother Munsell and Brother Holmes, and they felt greatly strengthened because of our sympathy and prayers. They took the remains to Springfield, Mass., for interment, after which they returned to the convention, more determined than ever to continue the good fight of faith until the Father should also say to them, come up higher. It is their determination to continue in the colporteur branch of the harvest work as long as such work can be done. Their

testimony to this fact will be found in another part of the Report, among the testimonies under date of Friday, October 4th.

## Sunday morning, September 29

The Convention opened Sunday morning, September 29, at 10 A.M. by singing No. 10, "All Hail the Power of Jesus' Name." This was followed by prayer by Brother Russell. Thereupon Dr. W. W. Murray, the representative of the local church, made an Address of Welcome and introduced Brother W. E. Van Amburgh, Chairman of the first part of the Convention.

### Brother Murray

Brother Murray's address was as follows:



Dear Brethren and Sisters in our Redeemer:--Through the partiality of our little church here, the pleasant duty and high privilege of welcoming you to this place, has devolved upon me. In all sincerity I could wish that this duty had been placed upon some one better able to discharge it in an acceptable manner, because "I am not eloquent, but am slow of speech, and of a slow tongue"; but with equal sincerity I can say that although my tongue can but feebly express my sentiments, you could not find a warmer welcome in any heart than in mine and in the hearts of those who have honored me by making me their spokesman on this occasion.

Next to the privilege of knowing the Truth and being permitted to be followers of our dear Lord in the path of self-denial and sacrifice, we esteem that of attending a convention of the Lord's dear people to be the greatest we shall enjoy until our earthly course shall be finished, and we, by the abounding mercy and favor of our Lord, meet in the Great Convention above, which is the object of all our hopes.

It has been my privilege to attend only three conventions similar to this, but my experience corresponds to that of all others who have had similar privileges -- that these conventions of the Lord's people are most precious, and helpful beyond the power of words to express.

As we look into each other's eyes, feel the warm clasp of each other's hands, and speak the words of welcome, we see and feel and hear nothing but love, love for our dear Heavenly Father, love for our blessed Savior, and love for one another, and on closer acquaintance with each other we find that this love extends to and takes in all mankind. This love of which we speak, this love which is in every heart and therefore in every eye and in every handclasp and on every tongue, is the one thing which, above all else, marks us out and stamps us as different from all other conventions of whatever sort that we have ever seen or heard of. And I am sure, dear brethren and sisters, that this one will not be different from the preceding ones in that respect, or if it be different, it will be so only in this -- that we love one another better than we ever have loved before.

We may liken this convention to a large orchestra, in which the musical instruments are represented by the individuals present. You know that in an orchestra each instrument must be in accord with each other, and that each must be tuned in accord with the keynote, otherwise, instead of the orchestra yielding music there will be discordant notes which will mar and destroy the harmony of the whole number. And so, in this orchestra of living, pulsating hearts, each must be in accord with every other one and with the keynote, otherwise there will be discordant notes which will mar and destroy the harmony of the whole. The keynote to which each heart must be attuned, is love, and so let each of us see to it that his and her heart is in accord with love which I suggest that we adopt as the keynote of this convention.

Brother Russell says in the "Towers": "The design of these general conventions is spiritual refreshment by mutual upbuilding along spiritual lines." We know that this is true, and all who are present have come for no other purpose than spiritual refreshment and mutual upbuilding. Now since love, perfect love, is the highest possible spiritual attainment, how can we better help to build each other up than by helping each other to attain to this perfect love? He who has attained to this perfect love has attained to the likeness of our dear Lord. To attain to this standard, so that when our earthly race has been run we may awake in His likeness, is the "hope that is set before us"; it is the one thing, in comparison with which all other things are but dross; it is the one thing for which all of us should be, and, I trust, are glad, as our brother Paul was, to surrender every earthly hope, desire and ambition, and like the same faithful servant of the Lord I hope we all can say: "Yea, verily, I count all things but loss . . . that I may win Christ, and be found in Him; . . . that I may know Him and the power of His resurrection, and the fellowship of His suffering, being conformed to His death, if by any means (however painful or humiliating in the eyes of the world) I may attain unto the resurrection of the dead," the First Resurrection.

Oh beloved, surely such is the desire of every one in this meeting; surely that is what each of us is striving for. Then let us cultivate the crowning Christian grace -- Love, and let us grow in love, and be built up in love, and thus be fitted to be enrolled as members of that Great Convention, the "General Assembly and Church of the First-born ones," which will shortly be convened, over which our dear Lord will preside in person, and from whose lips will fall the words of welcome which our hearts so ardently long for. May He be present in this convention; may He preside in every heart; and may His banner over us be the banner of Love!

I do not deem it would be in good taste, nor in harmony with your desire, that such an one as I should detain you longer from the rich feast that is about to be spread before you; therefore with these brief remarks, I, representing our little Church, extend to each and all a hearty and loving welcome.

I now take great pleasure in presenting to you as the permanent chairman of the first section of this convention, one whom many of us know, and whom all of us love, our dear Brother W. E. Van Amburgh.

## **Response to Address of Welcome, by Brother W. E. Van Amburgh.**

Dear Brothers and Sisters: I esteem it a great privilege to look into the faces of so many members of a royal family. When there is to be a meeting of royalty on earth, the meeting is heralded far and wide, and there is much inquiry on the part of the world as to who shall be there, and afterwards as to what clothes they wore, and how they appeared. But it is my privilege this morning to look into the faces of a number of prospective sons of the highest royal family of the universe, and we trust each one here has been giving close attention to the clothes he or she should have brought -- not the clothes for the body, we trust you have all been very careful indeed of that beautiful robe which has been provided for you by our dear elder Brother, the Lord Jesus Christ -- who was a pattern for us, who gave Himself for us that we might have His righteousness granted to us. In His name, as our dear brother has assured us, we are assembled here this morning, and I trust that as prospective members of this wonderful family we have been careful to provide ourselves with that robe.

In the great assemblies of the royal families of the earth there is a great deal of jealousy. I am surprised how the Adversary has perverted the use of almost every word in our language. The word "jealousy" now means to provoke to evil, to envy, etc., but I think the members of God's family have great reason to be jealous in the right way, for God himself is said to be jealous. There are different kinds of jealousy than that which the adversary uses. I trust each one here is very jealous -- that he is very jealous of his Father's reputation, and that he is jealous of his own reputation, that he will be very jealous of his actions, and that he will see that no action on his part or her part, while attending this convention, will bring any reproach upon our Father or upon the Truth. I trust that everyone here is jealous.

I trust that every brother here is a very provoking brother. Here, again, the Adversary has just turned this word upside down. The world thinks it means to provoke to evil, but the Scriptures speak of provoking one another to love, and I trust that will be true of every member here; that this will be a very provoking convention; that it will provoke everyone to more love than ever before; and this can be done in our thoughts and words and actions, and enter into all the little details of our assembling here together; that it will enter into all our associations we have in our rooms, that we will not leave our rooms in a more or less littered condition, but in an orderly condition. There is no son or daughter here but that can be preaching a sermon in the home or hotel in which he or she is stopping.

Again, the Lord's people came here for a purpose, and that purpose is to get something. The world wants to get something, too, yet the adversary again has turned this truth right around. In order for the world to get, they must get and hold fast to all that they get; but the Lord's people work in an opposite direction, for if they want to get a large blessing, they should give away all that they possibly can. That is the very best way you can get a large blessing; just begin to give it out, in smiles, hand-shakes, and in your thoughts and in your words, and the more you give the more you will have to take home with you. I am sure this has already been proved by many of you who are here this morning, and so I trust this will be the best receiving and giving convention we have ever had.

Another thing: I hope you have all come here just as full as your vessels would hold, but that you will go home with a great deal more capacity than you had when you came here, and that still your vessel will be full. In His prayer, our Dear Lord said: "Glorify (honor) thy Son, that thy Son may also glorify Thee." This prayer I think is appropriate for every member of the household of faith. The more we receive of our Heavenly Father's spirit, the more we will be able to give out to others. Friends, we are lamps, and the holy Spirit is operating in us and through us. For instance, take these lamps that are giving light tonight. The lamps shed forth the most light when they themselves are entirely out of sight, and the more transparent you can get the globe of glass, the greater the brilliancy of light; so the more you and I can get self out of the way, the more we will be able to reflect that wonderful light the Father has given us the privilege of having -- the Truth, the holy Spirit in our own hearts, in order that it may give brighter light to those with whom we come in contact.

The Lord provides abundantly. No one need go away hungry, and so I trust this will be the greater blessing to each heart because of the larger capacity to receive.

I thank you, dear brothers and sisters, and now let our prayer be that we might receive a fullness of love.

### **11 A. M. -- Discourse**

by Brother W. E. Van Amburgh. Topic, "Redeemed" (Titus 2:13, 14).

BROTHER VAN AMBURGH spoke, in substance, as follows:

"Looking for that blessed hope, and the glorious appearing of the great God and our Savior Jesus Christ; Who gave Himself up for us, that He might REDEEM us from all iniquity, and purify unto himself a peculiar people, zealous of good works."

The Apostle here mentions a hope which is peculiar to the people of God. It is a definite hope, and mentioned with a positiveness which only those who know God can experience: "The eyes of your understanding being enlightened; that ye may know what is the hope of His calling and what the riches of the glory of His inheritance in the saints." So positive is this hope that he says, "We are saved by hope." How different is the condition of the world! They "having no hope, and without God in the world."

The Apostle also mentions a love which is peculiar to God and those who have His Spirit. In the world in which we are living there is comparatively little manifestation of the genuine spirit of love. We are glad to note that there is some love in the hearts of mankind, but it is generally along more or less selfish lines. We have sometimes heard, "O Lord, bless me and my wife, my son John and his wife; us four and no more." It is almost impossible for the heart of the world to go out beyond one's own kin and include in the bonds of love those who are not specially near and dear to them by the ties of blood. The exemplification of love here mentioned by the Apostle is one that was so broad that it included all the world. Our Lord said, "God so loved the world that He gave His only begotten Son, that whosoever believeth in Him should not perish, but have everlasting life." Wonderful love; Godlike love; a love that would include even His enemies.

"But God commendeth His love toward us, in that while we were yet sinners, Christ died for us." Again, "Jesus Christ, by the grace of God, tasted death for every man." By this act He purchased the world, redeemed it from the power of the grave, became the possessor of all of Adam's race, by giving a "corresponding price" for our father Adam. The world has a great interest in this redemption, though comparatively few of earth's millions have ever heard of it as yet. God has thereby laid a foundation for the work of blessing "all the families of the earth."

But it is not in this particular sense that the word "redeemed" is used in our text. It is more the thought of "cut loose from," "loose away," and the context bears out this "That He might redeem us from all iniquity." Titus, to whom the Apostle was writing, had already accepted the justification which is by faith, as had also those whom Titus was serving as pastor. That was a necessary work, a primary work, indeed the foundation work upon which all else rested; but the words here refer more particularly to a following work.

We notice again that the Apostle calls our attention to our Lord's great love for us -- He gave Himself for us. There have been some noble examples of sacrifice in the world, for love of home, or of loved ones, or love of country. Our Lord gave all He had, and He had a great deal more to give than any one of earth had. He had life in its fullness; they had only a remnant. I trust that each waiting heart here this morning may more fully appreciate this gift of love and be more constrained by it. "My Lord gave Himself for me," should be the thought, "that He might redeem me." Yes, that He might redeem me from all iniquity and purify me unto himself, a peculiar one, zealous of good works.

This purifying process is not an instantaneous act. It is a gradual work, sometimes requiring years to complete. The redemption price having been paid, you and I can accept that by faith, at once; but it is not an actual justification. However, it gives us a standing before God, and it is counted to us as though it were actual. God counts us just, and grants us the privileges of full justification from sin, but assuring us it is only for a purpose, viz., that we may present our bodies a living sacrifice, "holy and acceptable (because counted just) unto him." Then follows the work of being justified in fact -- the purifying process, the taking out of the sin and evil and replacing them with the good. The Lord begins the work in us, "for it is God (through Christ) that worketh in you to will and to do His good pleasure," and little by little He gives us more knowledge, which multiplies our "grace and peace," and little by little our love for Him increases. We begin to see more and more of how much He loved us, and "we love Him because He first loved us" and continues to shower His love upon us. We are thereby "transformed by the renewing of our mind, that we may prove what is that good, and acceptable, and perfect will of God." But it does not consist entirely of thoughts; it must consist also of works, "Work out your own salvation, with fear and trembling." It is a very strenuous work we are engaged in, for we have many adversaries, within and without, seeking in every way possible to swerve us from our loyalty to God.

We call attention for a few moments to some of the peculiarities which the Apostle hints at: "Purifying unto Himself a peculiar people." They are peculiar only from the standpoint of the world. They are not peculiar in God's sight. Christ and the angels are not peculiar in heaven on account of their kind, gentle, loyal, loving characters. That is the proper and normal condition there, because God's will is done in heaven. But here we have surroundings that are opposed to

those of the heavenly conditions. The manifestations of the Spirit of God are peculiar in the eyes of the world, and hence His people are peculiar.

The world is looking for those things which will bring it pleasure, honor, riches, etc., in the present life, and is not overly conscientious as to the manner of obtaining them. God's people, on the other hand, are becoming more and more blind to the attractions of this life. To such an extent is this true that the world says, "They are fools; they don't know a good thing when they see it." They even called our Lord a fool, because He would not go with them after the glittering baubles of his life. Recognizing His great abilities, they realized that he could easily have raised Himself to the highest pinnacle of earthly fame. Why did He not do it? Our Lord became blind to all these. He would not look at them. Neither do those who are being purified by Him. In contrast to this blindness for some things, He was very keen-sighted in regard to other things. He was looking at the things which are not to be seen with the natural eye. And so has He been anointing the eyes of those whom He is purifying, that they also may be able to look at the things which are not (now) seen by the world. Is not the prospect glorious, as we begin to see something of the lengths and breadths and depths and heights of the love of God -- as we realize more and more His great love for us? It is no wonder we lose sight of the things of this world, and its rewards.

The Lord's eyesight is peculiar in other ways. He is blind to the many bodily imperfections of His chosen ones, does not "see" the many slips they make, but looking rather at the heart, sees through the flesh to the motive of love which endeavors to do all things as unto Him. The Lord looketh not upon the outward appearance, but upon the heart. So too His peculiar people are endeavoring not to see the outward imperfections in each other, not to see faults, but to see all the good things possible.

The Lord's people are also peculiar in their hearing. They have lost their love for the sounds of this world, and are so intent upon listening for the words of the Lord, that some can almost be said to "hear a look" -- "I will guide thee with mine eye." They are swift to hear all the good they can about each other; to say all the good things they can about each other, but very slow to "hear," listen, to any evil report. They stop their ears from hearing evil.

The Lord's people have peculiar memories. I have met a great many and have heard them say, "O, my memory is so poor; if I could only retain what I have read or learned -- if I could just remember the Lord's Word." That would be grand; but it might have a tendency to puff us up, and we might think our good memories would recommend us in the Lord's sight, and we would not have the proper sympathy for those who could not remember so well. There is one thing, dear brothers and sisters, that we can remember, to assist our imperfect retentive powers. And what is that? We can remember where to go to get food which gives renewed spiritual vitality. Although we may not be able to lay up a very large supply in our earthen vessels, yet we can remember that from our Lord's Word we can draw fresh supplies whenever needed. This is something which the world cannot remember, for they of the world have never learned where it is. It is also something which many of God's professed people have forgotten, and they are now seeking for food among the theories of men -- "Like the sow that was washed, returning to her wallowing in the mire."



The Lord's peculiar people have very good memories as to where the source of supply is, and that is the next best thing to being able to retain it in our memories all the time. The Lord has so arranged His Word at the present time that we can carry the whole commissary department in our pockets. In such a beautiful compact way is this wonderful Word we have here condensed (exhibiting the Bible) that we can carry the whole storehouse with us wherever we go.

Contrarywise, the Lord's people are very forgetful. They will even forget "their fathers' house." They will forget all about the pleasures of this world, and its glittering attractions. Why? Because they are so engrossed with those things which are coming. They know that the things which are coming are eternal, and far more to be desired than the things of the present.

They also learn to be forgetful of the little slights and imperfections of the flesh on the part of their brothers and sisters, and their forgetfulness and blindness are working together. Blind to the imperfections of the flesh, and forgetful of the past and its failures, they have all the more time and energy to do "this one thing," as the Apostle expresses it. Just the opposite to the world, who are looking for faults in others that they may take advantage of every failure and turn them to their own benefit. "Your sins have I forgotten, and I will remember them no more." Dear brothers and sisters, how glad we are that our Father has that kind of forgetfulness; that He remembers our sins no more. Why, then, should we hold resentment in our hearts, towards any? "Vengeance is mine; I will repay, saith the Lord." Hence we have no time or desire to do any of the recompensing for evil done us. "Blessed is the man whose sins are covered." Thus the Lord indicates that He manifests a blindness to some things. How glad we are that He does not look on the flesh, but through the flesh into the heart. He desires that His people should become like Him.

Then the Lord's peculiar people are very faithful, full of faith. "They know in Whom they have trusted, and are persuaded that He is able to keep that which they have committed unto Him against that day." There are some who profess to be followers of Christ who are not over a quarter full of faith and about three-quarters full of doubt. These do not have much enjoyment in the service of the Lord, and they do not have much enjoyment in the pleasures of the world. They have just enough faith to make themselves miserable while trying to enjoy the world, and not enough faith to trust the Lord and enjoy the delights of fellowship with Him in the narrow way. When you and I find our spring of joy running low; if we find a great many things disturbing us and causing us to doubt, we had best examine our faith to see that we have a full supply, for if our faith is full we will have no room for doubt. Our Lord says, "according to your faith be it unto you." If the vessel is full of faith the result will certainly be joy, peace, happiness, loyalty and zeal.

Faithful also means trustworthy, to be depended upon. Our Lord is always faithful, and to be depended upon. So should all His people be, even unto death.

The Lord's people are also very persistent. I remember the advice given by our dear Brother Russell on one occasion. A sister had questioned him something about as follows.

"Brother Russell, I am so troubled with the things of this life -- it seems almost impossible for me to keep my mind centered on the things of the Truth."

"Well," he said, "my dear sister, set your affections on things above."

"Brother Russell, I do, but they tumble off."

"Very well; set them there again."

"I do, Brother, but they tumble off again."

"Well, set them there again."

"I know I do try the very best I can, Brother, but they fall off again and again."

"Very well, keep on setting them there again and again, every time they fall off, and doubtless you will find it easier to keep them there longer as your power of mind increases."

It is often hard work to keep our thoughts set on things above, but the continual effort will establish a habit, and that will soon become part of our character, which is what the Lord desires. He wishes a peculiar people, like unto Himself.

Suppose we use an illustration. We will suppose that here is a large bank of clay. There is nothing of beauty in it, though there may be some chunks of coal, but they are all covered with the sticky clay. Some one buys the bank and begins to take out lumps of coal and lays them by themselves. They have been purchased, and the owner may dispose of them as it may please him. Though they have been taken out of the bank and placed by themselves, yet they are covered with the clay and ill shaped; not in shape to use for building or otherwise. They must first be washed, then shaped and polished and made fit for use. We might liken the taking the lumps out of the bank to the Lord's people being justified by faith. They are separated from their former surroundings and set in a place by themselves, but still actually unclean. They are dirty, and in no fit condition to use. The Master wishes to take them and cleanse them actually; then to so change them that they shall become beautiful, symmetrical, polished, and then build them into a beautiful temple. He begins to wash off the clay, little by little; then applies various solutions, pressures, degrees of heat until they are actually changed into diamonds. What a change: From a piece of black coal to a lustrous diamond! But there is much to be done yet. The diamond is not in proper shape. The lapidary must now begin the chiseling work of cutting to the desired pattern. This is sometimes slow, laborious work, hard for the lapidary and tiresome for the diamond. But at last, when finished, what a beautiful diamond appears! Such a gem that the lapidary holds it up to view with pride, that others may see and enjoy its beauty also. It has now been entirely redeemed from its former condition, and redeemed unto the ideal in the mind of the designer; as our text implies, redeemed unto himself. But this is not all. The Master now intends to build a temple, and to build it of these diamonds. Can the imagination suggest anything more glorious. Picture to yourself a temple, designed after the plan of God Himself, every stone resplendent with glory, with the light of the Sun of Righteousness shining forth from every point. Surely such light will be able to lighten the universe.

The Apostle speaks of the Lord's people as being "lively stones, built up a spiritual house." The Scriptures inform us that our Lord Jesus, in all His glory and brightness, is the chief corner-stone in this glorious temple. A beautiful picture, is it not? Redeemed from all iniquity and purified unto Himself! He took us out of the bank of clay, washed us, cleansed us, transformed us, that He might make us like unto Himself; to build us into a holy temple -- the Temple of God. Is it any wonder that we desire to "give heed unto the things which we have heard, lest at any time we let them slip?" Appreciating the "good pleasure" of God towards us, we desire to have no wills of our own, but to have His will done in us at all times and in all places, for it is to be "God that worketh in you to will and to do of His good pleasure." His "good pleasure" for us is far beyond anything we could have hoped or imagined for ourselves.

The Lord's people are to be zealous. There are many zealous people in the world. Zealous Methodists, zealous Presbyterians, zealous Baptists, zealous Catholics, zealous temperance advocates, and many zealous for good works. The Lord is selecting a people who are peculiar for their zeal for good works along a particular line. Some who are willing to work at "inside work," where it may not make much display before others at the present time. By the acuteness of their hearing they hear the Lord's word, "This is the will of God, even your sanctification." "Fret not thyself because of evil doers, for in due time they shall be cut off." "Therefore wait ye upon me, saith the Lord; until the day that I rise up to the prey." They believe the Lord's word that the burden of the world's sin is not upon their shoulders, and they leave that anxious care with Him, knowing that He is able to accomplish all that He has promised. They listen again: "Sanctify them through thy truth; thy Word is truth." "Not every one that saith unto me, Lord, Lord, shall enter into the kingdom of heaven, but he that doeth the will of my Father which is in heaven." Not even great works are commendable in His sight unless they are done in harmony with His arrangements. "Many will say unto me in that day, Lord, Lord, have we not prophesied in Thy name? and in Thy name cast out devils? and in thy name done many wonderful works?" He had not sent them out to do these works. The Lord's work and ways are peculiar in the eyes of the world. "That He may do His work, His strange work; and bring to pass His act, His strange act." So His people, following His instructions, seem strange in the eyes of the worldly wise.

The ways of His people seem strange to others in many respects. How they delight in the fellowship of each other, those whom they love in spirit and in truth, even while here in the flesh and covered with many blemishes. For they look not upon the outward man, but upon the heart. We did not come here expecting to find the most beautiful faces, or the best-dressed folks, or the most highly educated, or most affable or most refined of the world. But we did expect to find some of the most loving people to be found on the earth, because they would have much of the Lord's Spirit, and He is the personification of love itself, and all who love Him must love each other and be lovely in desire.

Another peculiarity is their manner of speech. They seem to some to have almost a strange tongue. Talking so much about the Lord, His love, His Mercy, His patience, His willingness to forgive and receive back into fellowship those who may have committed an error and repent of it and ask His pardon; His beauty, His knowledge, His power, His wealth and ability, and His approaching marriage -- all these speak of themselves as though they were His Bride. The world says, "What are all these people talking about? They have so little to say about any one unless they can say something good, and if we begin to tell them some good bit of gossip they don't

care to hear at all, and immediately turn the subject. We cannot understand them. Mention God, heaven, Christ, and the day of judgment, and they are interested in a minute and can talk by the hour. How strange!"

Now, taking up the first part of our text, "Looking for that blessed hope." Indeed it is a blessed hope, one that inspires all the energy we can command. O, dear brothers and sisters, you and I would not be able to fight this fight if it were not for the hope held out to us. The Apostle says, "We are saved by hope." This hope that is held out to us so strengthens and enraptures us that we are able to forget the trials and difficulties of the present time to a large extent. The eyes of our understanding have been enlightened that we may know what the hope of our calling is. It is a hope that has a foundation, and that foundation is the Word of God. Truly it is a glorious hope – a hope that animates every power of our being when we begin to rightly appreciate its value.

"And the glorious appearing of our great God and our Savior Jesus Christ." The manifestation of our Lord in glory to the world. We now see Him by the eye of faith. In this manner He is already manifested to us, through the eyes of our understanding, but He is yet to appear to all the world. He is yet to make Himself known to all the earth, for He has blessings for "all the families of the earth," and they are to know of these blessings that they may receive them if they will. And when he does thus appear we are to appear with Him in glory. "When Christ, who is our life, shall appear, then shall ye also appear with Him in glory." "As the Father hath loved me, so have I loved you." "I will that they also, whom thou hast given me, be with me where I am."

As our dear brother reminded us this morning in his remarks, this great bond of love is stronger than the law of gravitation. We have a law of gravitation which holds all the material bodies of the universe in their places; but God has another law which binds the hearts and minds of those who are in harmony with Him by a bond which nothing can break. The Father is the great center of this attraction, and He is drawing all our hearts together unto Himself through Jesus Christ our Lord. It is said of the Lord's people they love each other before they meet, and this is true. We certainly do. Many of us had never met before we came to this convention, yet we all loved each other before we came. Why? Because we all loved the Lord, and if we loved Him, how can we help loving those who love Him and whom He loves?

This drawing has been in progress for over eighteen hundred years and is still working -- is working here at this convention, and I trust we may all be drawn much closer to the Lord and to each other before it is over.

The Lord also calls His people lamps or small lights now. When all these lights have been gathered together, the imperfections removed, and they are lighted with the light of immortality, then shall they shine forth as the sun, and shall lighten all the earth. No corner will be left in the dark, so bright will be the light from the glorious sun.

Our Lord's words are, "Ye have not chosen me, but I have chosen you" to be my Bride, and that I might present you unto Myself, "A glorious Church, not having spot or wrinkle, or any such thing; but that it should be holy and without blemish." Truly a blessed hope, to be able to see Him as He is, and to be with Him in His glory.

Redeemed; Redeemed;  
O, joy that I should be  
In Christ, In Christ,  
From sin forever free;  
And asked by Him to share His name,  
His wealth, His glory and His fame.

Redeemed; Redeemed, from sin and all its woe;  
Redeemed; Redeemed, eternal life to know;  
Redeemed; Redeemed, by Jesus' blood;  
Redeemed; Redeemed, O praise the Lord.

## **"To Hell and Back."**

3 P.M. -- Brother Russell spoke on: "To Hell and Back."

This was the only service especially for the public, although any who cared to attend were welcome at all of the services.

That forenoon a large corps of volunteers distributed slips in Norfolk and Portsmouth announcing the service, and as a result there was a very large attendance, variously estimated from twenty-two hundred to three thousand. Close attention was given by those who could hear and all on leaving were served with the "Hell" Tower, which takes up in detail the subject of hell, etc.

Brother Russell was introduced to the audience by the mayor, who in a ten-minute address asked for an attentive hearing, that while he did not class himself among the truth people, yet if we had any truth he wanted it and said that they ought to want it also.

Norfolk never had so much truth proclaimed within its walls and as a partial result two ministers attempted to refute the arguments of Brother Russell. One, the Baptist minister, preached on "To Hell and Stay," reading some quotations from the first volume of Dawn, but not understanding how to rightly divide the Word of Truth, he was not able to place the quotations in their right connection, and only served to confuse his hearers more than ever. The Methodist minister preached on their favorite topic, "To Hell and be Damned." While one of the brethren attended the service at the Baptist church, we do not know that any of the brethren attended the Methodist service.

Brother Russell spoke for nearly two hours, driving each point home with scripture after scripture citation, and if there were any present with ears to hear, they certainly must have heard.

## The Hopeless and the Hopeful.

All Mankind Belonging to One or the Other Group. -- The Hopeless More Numerous.  
-- Hopes Good and Bad, Sound and Unsound.

*At 7:30 p.m. Brother Russell spoke from the text: "At that time ye were without Christ, being aliens from the commonwealth of Israel, strangers from the covenants of promise, having no hope, and without God in the world. But now in Christ Jesus ye who then were far off are made nigh by the blood of Christ." (Ephesians 2:12, 13.)*



Brother C. T. Russell.

OUR text shows us that the Christians of Ephesus, who came into a good hope through faith in the precious blood of Christ, were previously hopeless, without God and having no hope. If we apply this inspired gauge or standard to the whole world today we find the great mass of mankind to be hopeless, and hence unhappy, burdened, downcast, miserable. And surely as we look into the majority of the hundreds and thousands whom we meet daily, we see their hopelessness, their dejection, plainly written in their faces. True, in some cases we see mirth, in others carelessness, but these are by no means the majority, and even with them a closer acquaintance shows that they are trying to be happy, trying to be mirthful, trying to be careless, rather than succeeding. And what we see on the faces of the most civilized of humanity may be still more closely discerned in the countenances of the heathen in general. Extremely few faces notify us that love, joy, peace, reside within, building upon a blessed hope. True, in every land there are some so rich in wealth and honor and friends that seemingly they have no need of hope for anything either in the present life or in the future. But these are exceptions also, and very many of them betoken, not only in countenance, but in words, that they have not a satisfying portion -- that their riches of various kinds only partially satisfy the longings of their hearts; that they know of a surety that the present life is fleeing, and that they have more or less trepidation, fear, unrest, whenever they think of the future -- beyond the grave.

### Hopeless Thousands, Millions.

Statistics divide the population of earth into 400,000,000 Christians and 1,200,000,000 heathen - just twice the number there were a century ago. It is hard for us to comprehend such large numbers, but, according to our text, this immense host of heathen are without God and have no hope in the world -- they are hopeless. We should notice, however, that the Apostle does not state that there is no hope for these heathen, but simply that they do not have the hope. According to the Apostle, God's favor is all centered in Christ; and only those who know of Christ, and of Divine mercy arranged for through Him, can possibly exercise faith in Him, and hence only these believers could have the glorious hope which center in Him and await fulfillment at His second coming.

Indeed we may say that the heathen are worse off than hopeless. They not only do not have a hope, but instead of it they have fear, a most awful fear, which overshadows all the affairs of the

present life. Spiritism -- more truly "demonism" -- has long exercised itself amongst them, besetting, threatening, obsessing and tormenting them. It has taught them to fear God as the great arch-demon, and to expect a future life with new and still more trying difficulties than those they now experience, so that with many the only hope of escape from trouble is the belief that they shall ultimately become oblivious of everything, both good and evil. Alas, poor heathen! How much they need enlightenment. They do not need rum, tobacco and opium from the so-called Christian nations -- neither do they need to be taught their profanity and vices; they have enough of their own. But they do need sadly indeed the light of the knowledge of God as it shines in the face of Jesus Christ our Lord. They do need the true Gospel which the angels proclaimed at the birth of Jesus, "Good tidings of great joy which shall be unto all people."

### **"Another Gospel -- A Corrupt One."**

With commendable zeal, but not according to knowledge (Romans 10:2) missionaries have gone to the heathen from Christian lands in a spirit of devotion and self-sacrifice. Some of these have gladly laid down their lives in the service of the heathen according to their light, while others as hirelings, performed the duties required of them by the denominations supporting them as the easiest and smoothest path in life. As the Apostle suggests, however, Christ is preached, whether of devotion or denominational strife. But alas! the true Gospel of Christ is rarely heard -- rarely reaches the heathen ears. What they do hear is confusing, bewildering. The trumpet has an uncertain sound. The Methodist's bugle sounds "free grace," the Presbyterian "election" and "predestination," the Baptist and Disciple "water," the Roman Catholic and Episcopal "apostolic succession." To the heathen mind Christ is divided, and His followers cannot agree amongst themselves as to what His teachings are and as to what message should be proclaimed. There are two points upon which they all agree. (1) All mankind are sinners -- "born in sin" -- and (2) that Christ Jesus is the only Savior; "for there is none other name given under heaven or amongst men whereby we must be saved." (Acts 4:12.) They all agree that the heathen are not saved in ignorance of Christ, and that the missionaries have gone to them to proclaim Christ and to lead them to faith in Him in order that they may be saved. As the Apostle says, "How shall they believe on Him whom they have not heard?" for "faith cometh by hearing" and hearing depends upon the message of God.

### **Grand Truths Confused by Errors.**

In all of the above teaching respecting the necessity of faith in Christ as our Redeemer we heartily agree. This is the very kernel and essence of the Gospel of Christ, as set forth in the Word of God. But the beauty and force and blessing of this gospel message is vitiated by a terrible error, which crept into Christian faith in the dark ages, namely, that the salvation which Christ accomplished for us is a deliverance from condemnation to a fiery hell of eternal torment. This is untrue -- unscriptural. It is a slander upon our great Creator to declare that He made our race subject to such awful conditions -- to declare for instance, that the heathen who died during the past 6,000 years -- thousands of millions of them -- without any knowledge of the Savior, therefore, without any faith in Him, and therefore without any hope in Him, have gone down to a hopeless eternity of torment and despair. This is one of the doctrines which the Apostle Paul styles "doctrines of devils." The heathen get enough of this through their own demonology before the Christian missionaries ever preached to them, but it is doubly sad that, when the

message of the love of God as manifested in Christ is being proclaimed to them, this "doctrine of devils" should be attached to it and apparently confirm the demonology under which the poor heathen have so long been held in bondage to Satan.

Can we wonder that the poor heathen, who have been taught to worship their ancestors, should be shocked with this false Gospel message that all of their forefathers have been turned over to fire-proof devils to be eternally tormented -- because they were not fortunate enough to hear and accept "the only" name under heaven given among men whereby we must be saved?" We can fancy the poor heathen saying, "Is this your God of love? And pray what are your definitions of the words love and justice? You who claim to be the only exponents of the only plan of salvation, is this the best your God can do for us? If He is loving, is He powerless?" Alas! alas! The difficulty is not with our all-wise, all-powerful, all-just and all-loving Creator, nor with the glorious plan for human salvation which He has centered in His Son, our Lord Jesus Christ. The difficulty, the inconsistency, is in the error which has become mixed with the Gospel of Christ as set forth in the Bible. The Apostle spake of some in his day who preached another gospel, and so it is today. In the name of the one Father, God, and one Savior, our Lord Jesus Christ, another gospel is being preached, not only among the heathen but also in civilized lands -- a false gospel -- an untrue message, which misrepresents the truth, and is a slander, a grievous slander, upon the divine character.

### **"Good Tidings of Great Joy."**

We have seen the hopelessness of the heathen, and how little hope is afforded them in the message that is being preached to them in the name of God and of Christ. Not only is this message one of despair as respects their forefathers, but equally so as respects the great mass of their living kindred. Indeed, as the Prophet has pictured this erroneous teaching, it is like a bed that is so short that a man cannot stretch himself on it -- cannot exercise his mind and heart so as to find rest therein; and, as the Prophet continues, "the covering is so narrow that a man cannot wrap himself in it. If he tries to convince himself that he is one of a very select class, destined for eternal blessedness, while the great mass of mankind are destined for eternal woe, he cannot help it that fear will creep in just as do the chilly winds upon the person who has too narrow a bed covering. He is bound to fear that the apparent partiality of God in permitting his escape from eternal torment, to which millions of others are consigned, may some day change toward him and drop him also into eternal misery. (Isaiah 28:30.)

Let us turn now from these obnoxious misrepresentations of the Divine character and plan and note the beauty and simplicity of the Bible's teaching respecting what man was condemned to, what he is delivered from, and of what his salvation shall consist. Let us note first how different the tone, how different the ring of the Scripture references to the Gospel from anything that could properly be applied to these false gospels, these misrepresentations of the Divine plan which have come down to Christendom from the dark ages. Hearken to the first word from the Lord respecting the Gospel -- the message to which St. Paul refers when he says "God preached the Gospel in advance of Abraham, saying, 'In thee and in thy seed shall all the families of the earth be blessed.'" (Galatians 3:8.) Is this the Gospel of salvation or of damnation, good tidings or bad tidings? Assuredly the former. Indeed, as all are aware, this is the very meaning of the word "gospel" -- good tidings.



How evidently then some terrible, awful mistake has been made by somebody when the message of eternal torment for 999 out of every 1,000 of earth's teeming population has been called Gospel. The Word could not have been more seriously perverted, for that surely would be bad tidings of great misery for practically all people. But this first message of the Gospel to Abraham tells of the blessing of all the families of the earth -- it excludes none. It extends backward as well as forward. It takes in the families of the earth that were living before the flood as well as those living in Abraham's time and all who have lived since, and all who will live in the future. God's promise, the Gospel message, is that all of these shall be blessed. Have they been blessed yet? Assuredly not. Blind indeed would be the eyes of understanding or judgment that could suppose that this gospel blessing has yet come to all the families of the earth. Note again a very similar statement of the New Testament -- the message of the angels at the time of our dear Redeemer's birth. They said to the fear-stricken ones before them, "Fear not, for behold we bring you good tidings of great joy which shall be unto all people." All Christian people, whatever trumpet they blow, by whatever name they are known, claim these records and translate them just as we have done. It is when they come to apply them that they fall short.

Those who believe in the doctrine of election would have us understand that God did not mean that the Gospel would be a blessing to all the families of the earth, "to all people," but merely to the elect, chosen out from amongst all nations and people. Those who hold to the doctrine of "free grace" would deny this, and declare that there is no election and no preference with God; yet their theory also would make these Divine promises of no effect by claiming that God has limited the blessings to the energies of His people, and that the most that these promises could mean would be that ultimately the zeal of the Lord's people shall be so great that they will accomplish the evangelization of the world, that the "all nations" of these promises are those of the future, and that the thousands of millions of all nations lying in the interim have been without any blessing and will have none. And these two messages are practically all the explanations of these glorious promises that the heathen have heard. Alas! Alas!

### **Two Errors Bar the Way.**

We have already intimated that errors handed down from the dark ages are casting this great cloud upon the Divine character and plan, and hindering a proper appreciation of the glorious plan of salvation which centers in our Lord Jesus Christ. The first of these, as already intimated, is a misconception respecting hell. The Bible "hell," as we have elsewhere shown, is not a hell of torment but of death, destruction, unconsciousness. According to the Bible, the penalty upon Adam, which descended to us, his children, in conformity with the course of nature, is the death penalty.

He, created in perfection and in God's image, might have lived forever had he been obedient; but, in disobeying, he came under the sentence, "dying thou shalt die." This sentence is the wrath, the curse, that rests upon all mankind. Dying, we all die, because we are the children of Adam and share his sentence as we share his depravity. Hearken to the Apostle's words on this subject, "By one man sin entered into the world and death (not eternal torment) as the result of sin, and thus death (not eternal torment) passed upon all men, because all are sinners." (Romans 5:12.)

According to the Scriptures, as well as according to the facts as we see them, both the wise and the ignorant, moral and immoral, believers and unbelievers, die, go into Sheol, into Hades, into the state of death. This dying process has continued now for over 6,000 years, and it is estimated that 20,000,000,000 have been "born in sin, shapen in iniquity (Psalm 51:5), lived in more or less depravity and imperfection, and died with more or less of pain, sorrow and hopelessness. The tomb, the great prison-house of death, is well filled with almost enough to reasonably populate the earth. The Scriptures declare that "they know not anything." (Ecclesiastes 9:5.) They have not gone to a heaven of bliss, for our Redeemer declared that "No man had ascended up to heaven." (John 3:13.) The Apostle Paul declares that "David the Prophet has not gone to heaven." (Acts 2:34.) The wise man declares that they are all in Sheol, Hades, the tomb. (Ecclesiastes 9:10.) Our Lord again declares that they are all in their graves. (John 5:28.) How glad we are that this great mass of mankind are neither in a hell of eternal torture, suffering at the hands of fire-proof devils, nor in a purgatorial inferno, as taught by our Roman Catholic friends. How glad we should be that the doctrine of devils which consign them to such tortures is entirely untrue, unscriptural, and we are not obliged to think that our heavenly Father is an arch-demon, but, according to the Scriptures, may know Him as a God of love.

We have elsewhere shown that those who translated our Bibles have in some instances twisted their translation in harmony with their misconceptions, and that our minds thus perverted have misunderstood some of our Lord's beautiful teachings, and been stricken with fear at some of the symbolical pictures of Revelation which we did not understand.

### **Hope for the Dead.**

The second point in error received in the dark ages is that which teaches that death ends all hope. There is not one word in support of that erroneous thought within the lids of the Bible. On the contrary, its teachings abound with hope for many of the world in the future -- not that the Scriptures teach that a knowledge of the grace of God now may be trifled with, but that the vast majority never yet had a full, fair opportunity to benefit by the redemptive work of Christ. Ignorance, superstition, depravity, and the God of this world have combinedly obscured the eyes of their understanding, more or less; and only in proportion as each has seen, has tasted, has appreciated the grace of God in Christ is each now responsible. This certainly throws the possible opportunities of the vast majority of the race into the future, and, as we shall shortly see, the Scriptures fully corroborate this thought, and promise to Adam and all of his posterity a full individual opportunity for return to harmony with God and of a possibility of life everlasting.

Let us remember that from God's standpoint the entire human race was sentenced to death as unworthy of life, because, as the Scriptures declare, "There is none righteous, no not one," and eternal life is intended only for the righteous. The Scriptures declare also that Jesus is a Savior and a great one, but human theories would make Him the Savior of a small handful of the race, and then declare that that handful get their salvation by their good works instead of by God's grace. Let us see what the Scriptures teach more fully. Let us note the beauty, grandeur, length, breadth, depth and height of the Divine plan therein set forth.

The Bible does teach an election -- that ever since Pentecost God has been choosing from Jews

and Gentiles a little flock, to be the Bride of Christ. They teach that evil is now permitted in order that the way of obedience to God may be narrow now, to the intent that these elect ones shall be thoroughly tried, tested and proven as respects their faith in God, their loyalty to Him and His righteousness. All of the New Testament Scriptures are addressed to this class – none of them to the world. Jesus prayed for His apostles and for all them who would believe in Him through their word, but added, "I pray not for the world." The reason for this was that He knew that this age was not the Father's time for dealing with the world, but the time merely to deal with those called to be the bride. To this bride is promised His exceeding great and precious promises -- to be partaker with our Lord of the Divine nature, to share His glory, honor, immortality and kingdom. The elect enter into these joys and blessings, not at death, but in the resurrection, as the Scriptures declare -- "Blessed and holy are all them that have part in the first resurrection." (Revelation 5:10; 20:6.) "They shall be kings and priests unto God and shall reign on the earth."

### **The Kingdom of Christ.**

Everywhere the Scriptures point us to the second coming of Christ and His kingdom of righteousness, which will then be established "under the whole heavens." (Daniel 7:27.) It was for this kingdom that He taught the elect to pray "Thy kingdom come, Thy will be done on earth as it is in heaven." (Matthew 6:10.) That kingdom has not yet come, God's will is not yet done on earth as it is in heaven. The Church with her Lord is to constitute that Kingdom, and it cannot be established until the gathering of the elect from the world has been accomplished.

The long-promised Kingdom of God is the hope of the world. Christ and the Church, spirit beings unseen of men, will take charge of the affairs of earth. Satan will be bound for a thousand years, that men may be free from his deceptive influences and from all the power of demons during that reign of righteousness. Then the "Sun of Righteousness" will scatter all the darkness of ignorance, superstition and sin, and the whole world will be brought to a knowledge of God in His true character as a God of love, a God of justice, a God of mercy, a God of power. So forceful will this be that the Scriptures describe the effect, saying, "Then every knee shall bow and every tongue confess." (Philippians 2:10,11.) There will be none in ignorance. Thus the living, under the judgment of the great King, will be instructed in righteousness and helped out of their fallen and weak condition back to their mental, moral and physical life and health and strength. And only those who will deliberately refuse and rebel against that reign of righteousness shall be accounted wicked, and be everlastingly destroyed in the Second Death without hope of a resurrection or any kind of recovery.

But this glorious hope is not merely for those who will be so fortunate as to live at, or after the second coming of our Lord and the establishment of His Kingdom. The Great King has all the power. He declares that He has the key of the great prison-house of death, Hades, and that it is His good pleasure that all that are in their graves shall hear His command to come forth -- the good and the evil. The first resurrection, as we have already shown, will consist of those who have hope, but the future resurrection will include all the remainder, who will come forth for a judgment or trial or test, to see whether or not their past experience with sin and their experience with righteousness will lead them to choose righteousness with all their hearts and thus choose the blessing of God, eternal life. Here we have the resurrection hope which the Scriptures

everywhere set forth. We remember the Apostle's words, "For the hope of the resurrection of the dead I am called in question. (Acts 23:6.) Again we read that the early Christians were scattered abroad and went everywhere preaching Jesus and the resurrection; Jesus as the One who redeemed us from the power of death, and satisfied for us and for all the demands of justice, and the resurrection power or method by which the blessing of Divine forgiveness will profit Adam and his race, recovering them to all that was lost.

Whoever will take a Concordance and look up what the Scriptures have to say about hope will be thoroughly convinced that as the heathen are without God and without hope, Christians are everywhere exhorted to hope and to allow this hope to be an anchor to their souls while they wait for the fulfillment of all the precious things God has promised through the Redeemer -- to be brought unto us at His revelation, at His second coming, at the establishment of His kingdom." (1 Peter 1:13.) Let us then search the Scripture that we may enjoy this hope and, as the Apostle says, "Be ready to give an answer to everyone that asketh us a reason for the hope that is within us with meekness and fear." (1 Peter 3:15.)

## **MONDAY, SEPTEMBER 30.**

*9:30 A.M. -- Praise and Testimony Meeting led by Brother C. A. Wise, of Indianapolis, Ind.*

A BROTHER: The friends while at Niagara Falls Convention sent home reports of how much they were enjoying the convention, it made me determined to attend one convention, and I came here for the purpose of receiving a blessing.

A Brother from Ohio: I am overflowing this morning. (Bro. Wise, let it overflow). I got the fever at Niagara and it has become chronic.

Bro. Murray: In a little town of seven thousand I am the only one, but the Lord is with me.

A Brother: About forty years ago I tried to be a Christian, but I walked in darkness until I found this glorious truth. Ah, brethren, you know something of what it is. I thought if I could remain in the Methodist Church and have the same things Bro. Russell teaches, etc. But eight years ago I came out and now have my shoulder to the wheel and I am trying to live it and preach it, and I feel I am one of the happiest of men.

Bro. Thorn: About fifteen years ago I attended my first convention at Allegheny, and I thought that was the grandest convention I could ever attend. I have since attended one convention every year and find that each is better than the last. In all the fifteen years there has not a cloud arisen between my Redeemer and myself. Now while we are enjoying these conventions and they are growing better, we believe the grandest of all will be when the Church of the First Born is gathered with her Head above, and the best thing about that convention is that it will never end.

A Brother: I believe a better name for our conventions would be "exposition," because we are exposing the graces in our hearts. I am glad to greet all and I am drinking in the convention blessings from the platform and from those with whom I shake hands.

Bro. Banks (colored), Cincinnati, O." I appreciate the privilege of meeting with the brethren and of being permitted to be classed with those who are suffering the ignominy and shame of the cross. If we never meet here again, I hope to meet with you in the great convention beyond.

There were many other excellent testimonies, but because of the noise from the street and the size of the hall, we could not hear enough of the testimonies to report. These, however, are an indication of the spirit of the testimony meetings.

## **10 A.M. -- Question Meeting** **conducted by Brother Russell.**

*(Note: The friends will please notice that we have not in all instance given Brother Russell's answers verbatim, as they were often quite elaborate, but we have tried in each case to give the substance.)*

**1. Question** -- Lev. 16:14: "And he shall take of the verbatim, as they were often quite elaborate; but we blood of the bullock, and sprinkle it with his finger upon the mercy seat eastward." Is there any special typical significance attaching to the finger of the High Priest?

**Answer** -- I do not think of any special significance in this word "finger" as it is used. It would be more convenient to sprinkle with his finger than with his whole hand. There may be some force or significance to the word "finger," but I never thought of it. If any of you think of it, I would be pleased to have you mention it to me.

**2. Question** -- When will the Great Company suffer the Great Tribulation, and will they be at the marriage supper of the Lamb?

**Answer** -- I answer that nearly all the Scriptural pictures with reference to the Great Company would indicate that the special time for their tribulation would be at the close of this age -- apparently just after the Church will all be gathered, -- as, for instance, the parable of the wise and foolish virgins. We remember that when the wise virgins, saying, Lord, Lord, open unto us, and the wise virgins had all gone in, then came also the foolish virgins, saying, Lord, Lord, open unto us, and they were told that the Lord would not recognize them as the Bride Class, and that they would go into tribulation. That seems to indicate that the special tribulation upon the Great Company class will be after all the Little Flock have gone in beyond the veil into the Most Holy. Now that is only a parable, of course, and we are building as wisely as we know how on that parable. Then in Leviticus it shows us the place where the Scape-goat is dealt with after the Lord's goat has been dealt with, but that is not proof positive that it will be entirely after the Lord's goat has been slain, and after its blood has been offered, because these types could not all take place at the same time, and there would naturally be an order for it, -- this first, and that second, and so on, but the fact that the bullock is dealt with first, and that the Lord's goat is dealt with second, and then the scape-goat is dealt with thirdly, seems to imply that the tribulation of this class will come more specially at the end of the Gospel Age, after all of the elect shall have gone in, notwithstanding we think there is room in the Scriptures to suppose that there have been some of this Great Tribulation Class all through the ages, while the great mass of them probably belong in this end, because of the peculiar circumstance now prevailing. Someone

perhaps will say, what are the peculiar circumstances now that would cause a larger class of the Great Company living today than at any previous time? The conditions that are favorable to them now are, that Christianity now is in a measure popular, and a great many people have heard of Christ and made a kind of a consecration to the Lord, and there is not that open persecution now which is sharp and distinctive; so that people are more likely to make a full consecration to the Lord now, and suppose that it is an easy thing, and when they get inside. and find that it is not so easy as they thought, some of them are disposed to hold back a little, and these will become of the Great Company, whereas in the past times when things were more turbulent and more sharply defined, it took more to make a decision. As our Lord mentioned, they sat down and counted the cost. In our day, they are not disposed to count the cost. They hear the preachers telling them that it is an easy thing. They say, in effect, come now, and you can have everything in a few minutes. You will be more prosperous in business, and get rich faster, and have better houses, more respect of your neighbors, etc. So, it is a time of enticing now, and these people are being enticed by these misrepresentations of the narrow way, and after they get in, they find it to be a narrow way, as the Lord will show them by and by, and so there is a larger number of this class today than in the past.

Now as to the marriage supper of the Lamb, we find the Lord picturing the Great Company Class. They say, "Let us be glad and rejoice for the marriage of the Lamb has come and she has made herself ready."

She was all ready and went in to the marriage, and we are left out, is the thought. Then they say, "Let us be glad and rejoice." Why should they rejoice? Why, by that time, their eyes are really opened, and they see Babylon as they never saw her before, and they see God's Plan as they never saw it before. They were not in the right attitude of heart to have a hearing ear and an appreciative heart, and therefore could not see the deep things, for God only gives us a deeper understanding of His Word as we come into the right condition of heart.

Now then, those of the Great Company in Rev. 19, are pictured as saying, Let us be glad and rejoice for the marriage of the Lamb has come, and the wife bath made herself ready, and they are glad of it all, and then they, go on to say, Babylon is fallen, rejoice, rejoice, ye heavens, in her fall, etc. They are glad that Babylon has gone down when they come to see what it really was and how much they were bound by it, and they did not realize how much blinding influence was coming from that source.

I want to say now, because some might not have taken this view yet, or have seen it in this light. So far as my observation and experience would go, the greatest hindrance to the work of God in the present time -- now mark you, to the work of God at the present time -- is what is known as the "Christian Ministry." Why, someone says, Brother Russell, you do not believe that? Yes, I do believe that. Why, are they. not doing thus and so, preaching a good deal of morality? Yes, but that is not the work of God for this present time. The work of God during this age is the taking out of a people for His name; finding the wheat is the particular work of God at the present time. Now they are doing a work that will be good in its way, and I admit that a great many of them are benevolent works, and I appreciate it all just as much as anybody does, and I am glad to see them doing that rather than doing wickedness, and I congratulate them on that. Nevertheless, you will find nearly all the obstructions to present truth is coming from the ministry. If it were not for

the ministers in all the denominations over the civilized world, the truth would spread among God's people like wild-fire. It is just as it was at the first advent. Who was it that hindered the people from believing in the Lord Jesus in that day? Why, it was the scribes and pharisees. Jesus said to them, "You shut up the kingdom against yourselves, and you will neither enter in yourselves, nor permit those who are entering to go in." -- you have taken away the key of knowledge from the people. So it is with the ministers of today, dear friends. It is just a parallel of 1800 years ago. They are standing in the way. They do not fully realize this, I am glad to say, and they are not as responsible as though they did realize it fully. I do not think they are without responsibility entirely. I do not think that men who have had an education and know about sheol, and hades, and who are allowing the people to sit under their preaching year after year, and suppose that they believe in eternal torment, fire, etc., when they believe nothing of the kind, and allowing these absurd doctrines which hinder the people from rightly worshiping God, are inexcusable. But then, it is with their own consciences and with the Lord, and I have no fight to make against them. I am merely suggesting to you more than I would say to them; because, why should we offend anybody needlessly? I should say to a brother who was in a right condition of heart, "Brother, if you are doing your duty, don't you think you ought to be setting forth the words of truth and righteousness, and the real character of God? Don't you think that is your privilege?" That is the way I would speak to anyone with whom I could speak in that way. But while they hold you at arm's length in their personification of dignity, if you were to ask any questions, you would find they could not answer the questions. -- They can hardly answer any Scriptural question properly. You try one and see.

I think of a brother who came to me and said,

"Brother Russell, I think I have been doing wrong. I have accepted these doctrines of present truth and believe them, but I did not go to ally of the ministers of the churches to ask them about them, and I think I should have done so. I think I have been doing wrong, because I am not a Greek and Hebrew scholar, and have not a great education, and here are these men with whom I am well acquainted, and who are learned and good men; I am well acquainted right here in this city of Pittsburg and Allegheny with some of the leading ministers, especially in the United Presbyterian denomination, because I have myself been working in all their different Sunday Schools, organizing temperance armies, and they all know me very well, and I know them to be fine men. Now then, my con-science has been telling me that I did not do right; I should have gone to them and said, Now Doctor so and so, can you tell me about this matter, is it true or not? What do you think, Brother Russell?"

I saw that he wanted to go, and that it would be the better thing for him to do, so I said, "Brother, I would go and do that. If you do it in a proper manner, it will do good."

"What do you mean by proper manner, Brother Russell?"

"I will tell you what I think would be the proper manner: when you go to the residence, for instance, Dr. A., you ring the bell and ask to see him, and when he comes to the door and you have your usual greetings, you say something like this to him: Doctor, I have some matters of a doctrinal nature that have been perplexing me and I thought I would like to ask your advice about them sometime when you have the time: I do not want to trouble you now, you may be

busy, and it will take an hour, and I want to come sometime when you have time to spare. Would you appoint me sometime? He will likely say, come right in, brother, this will do me just as well."

The brother said, "Why, Brother Russell, do you say so particularly that I should mind that?"

I said, "This is the reason: if you do not take that method to get him to say he will give you an hour, you would find that by the time you had told him what your question was, he would say, Well, brother, there is a sick sister that I must go to see, please excuse me and come in some time again."

"Now Brother Russell, you don't know. I mean Doctor so and so, and Doctor so and so; they are such fine men."

"Yes, I know those gentlemen more or less, and admit that they are above the average, but Brother, you do not know the difficulty they have when you ask one of these questions; they have a proposition before them they have never met before in their lives, and they do not know what to say, and that is the easiest way for them to get out of it. Of course there is in every large congregation one or two sick brothers or sisters at any time and they can truthfully say, I ought to call and see them, -- and they know they ought to get away from you, and from your questions. They think they are doing good to you for they know they cannot answer the question, and they think that is the quickest and best way to do it, and they think you will never get a chance again for they will dodge you every time."

"O, Brother Russell, you do not give them credit" "

"I do, brother, but you do not understand the situation, and I do. But, the minister will say, Yes, I can give you an hour now, come right in and sit down in the study. And you go in and he says, `Well now, what is your question?' " I said to him, "What were you going to ask them?" And he said, "Well, I thought to ask him one question specially that I was interested in, that one about Restitution, where the Apostle Peter said, Restitution shall come from the presence of the Lord, etc. Now, that is the question I thought I would ask them." I said, "That is a very good question, you just stick to that question. But, when you get in and sit down and he says, What is your question, and you tell him the text of Scripture, you will have to be on your guard, for that man will say to himself, My conscience! That question, why, I do not know any more about the answer to that question than I would know how to jump over the moon. What will I do? I have told this man that he could have an hour. My conscience! what will I do? Well, what will he do? I will tell you what he will do brother: He will say to himself, I have just got to mix this man up so that he will not know which end is to. I will razzle-dazzle his mind and confuse him all over -- body, soul and spirit, hell, hades, sheol. I can do that. He does not know much; I know he is not an educated man.

"O, Brother Russell, Doctor So and So would not do that."

"Brother, I know they will do that because that is the only thing they could do. They would either do that, or else they would come out flat-footed and say, Brother, that is a scripture that I do not



understand. I wish I did, and if you ever find the interpretation of it, bring it to me. If they were thoroughly honest, that is what they would do. But after some large institution has said to them, 'You are a doctor of divinity, you are fit to doctor even divinity now' -- when they have got all of that, then for a little man to come in and say, here is a plain question to answer, and they cannot do anything with it, it requires a great deal of humiliation to acknowledge the fact.

I said to him, "Now, when he begins to talk this way, and tries to mix you up and ask you about so and so, and tries to confuse you, you say, 'O doctor, I do not seem to have stated my question properly.' Put the blame on yourself. You can do that honestly, you know, because you are not bound to suppose that he is trying to evade your question; you have just as much right to say to him -- I have not stated my question properly. Say to him, 'Doctor, I do not seem to have stated my question properly; that is not the question you are answering. The question I wanted to ask you was about the times of restitution of all things; what does that mean? You must bring him back to that; and he will try again to get you mixed up. But you say, 'O Doctor, I do not get my question straight; I wish I knew how to state my question properly. I want to know about the times of restitution.' You hold him right down to that, brother, and there is not a doctor of divinity in this country or state that can match you with the knowledge of the Word of God, and you have been only three months in the truth."

"Brother Russell," he said, "instead of trying to catch him and hold him for an hour, I thought I would have to try to get loose myself, and prevent them from holding me."

I said, "No, brother, you have not the idea; you will have to try to hold them down to the question, because they cannot answer it, and they know they cannot, and they will try to get you mixed up. And they will not admit that they cannot answer it."

And this reminds me of another gentleman. As I was going down the street near the Bible House, walking a little more rapidly than usual, I passed him. I suppose he recognized me and said, Brother Russell, a moment. And he caught up with me. He was a man that I had never spoken with in my life. He was a very nice-looking gentleman, well dressed. I did not know who he was. He gave me his name, but I have forgotten it. He said, "I wanted to ask you a question about a parable." I thought that was very queer for a man to meet you on the street and ask you that kind of a question. I said, "What parable is it, brother?" He told me -- I have forgotten now which one it was -- but it was a very simple, plain parable, and I answered the question and explained it very easily, I think, in about two minutes' time. "Why," he said, "that is very simple, very satisfactory," and repeated, "very satisfactory."

I said, "How does it come you are so agitated about so small a matter as this?" He said, "I wonder why it is my preacher cannot tell me that. I belong to Dr.

Kennedy's church, just opposite the Bible House -- the principal Presbyterian church in Allegheny -- and I have gone to him and asked him that very question."

"Now," he said, "you would have thought I was the most stupid man on earth, and he practically told me, why, you have not sense enough to understand it if I were to explain it to you. He made me feel like a very small potato. I have never thought that I was a great man, but I thought I was

deserving at least of reasonable treatment, that he might have tried to tell me, and then if I could not understand it, it would have been my fault. He just sat down on me instead of telling me; he did not tell me anything about it. Now, what do you suppose was the reason for that?"

I said, "Brother, I guess the reason why he did not was because he did not know how to answer it, and thought that was the best way to get out of it."

He said, "I wonder if that was it."

We know, dear friends, those of us who have had such an experience, that that was just the difficulty. Dr. Kennedy is a very able man, a very fine man in many respects; I am not speaking to his discredit as a man, or saying a word against his character; for as far as I know, he is a well educated minister, and he must know about a great many things. He knows what sheol is -- at least I cannot suppose that he is stupid and ignorant enough not to know, after all the opportunities he has had to know.

This man went on to say, "Well, I could not help thinking that if I was the most stupid man in the congregation, they should not have selected the most stupid man as an elder."

I said, "brother, I do not think it is entirely your stupidity."

He said, "I have head enough to understand it when you explained it."

Now, I merely mention these things to illustrate the point.

But coming back to Rev. 19, where it says, "Let us be glad and give honor to God, for the marriage of the Lamb has come, etc." They were glad when they found out the true situation, that God had delivered them, and that the institution was a hinderance to God's plan in many respects. While they do good in the way of building hospitals perhaps, and inculcating some morals, and keeping some people out of the saloons, and sometimes getting up a saloon law, and sometimes an underground saloon so as to keep people from going to a saloon of a worse class, some-times having a bowling alley to keep people from going to bowling alleys where they get whiskey, -- with all of this they are trying to act in a moral way. I give them credit, I think, for all they claim them-selves, but as for teaching sanctification of the spirit and faith in the precious blood of Christ, I do not think many of them pretend to be doing that; I do not think many would say that was their true mission, and what they are trying to do. On the contrary, they would say that they must go after the people, save the masses, and in trying to save the masses from something, without having their hearts changed, they are neglecting the true people of God who need to have the feeding, as God tells us, "Feed My sheep." Our Lord when He spoke to the Apostle Peter did not say anything about going out and catching some wolves and putting sheep's hair on them, and finding some rattle snakes and fixing them up and making them look like sheep. You take care of the sheep, and the lambs, and the Lord will take care of how they got to be sheep and lambs. He is to do the drawing. It is whosoever the Father draweth that comes to Him. "Whosoever cometh unto Me, I will in no wise cast out." You and I are not to try to smash people's hearts, or their heads either. Let the providences of God do all of the breaking of hearts. The Gospel He has given to us is to bind up the broken hearted, and take hold of the sheep and

lambs and feed them; that is God's proposition. We want to stand by the Lord's Word. We have not the confidence in our own hearts that we are wiser than the Lord; we would not take a bundle of bramble bushes and tie a few bunches of grapes on them and say, these are genuine grape vines.

But these will find that the fall of Babylon, the complete overthrow of the human systems, has really worked a good. Then they are represented as getting a special message from God, saying "Blessed is he that is called to the marriage supper of the Lamb." Now there is a difference between being at the marriage and eating at the marriage supper, -- that which is accomplished when the wise virgins go in and the door is shut, but the marriage supper did not take place for a little while after that. The marriage supper, of course, is just a grand picture before our minds. There is really no sitting down to eat or drink, but it is merely a picture of the joyous occasion that will follow. And to these great festivities, the Great Company are invited to come and share. They were not loyal enough to lay down their lives, but they had loyalty, because they would not deny the precious name and blood, and therefore the Lord would not deny them, and there would be a place for them; they would have an opportunity to come in to the marriage supper and have a share in the rejoicing. Just as in the 45th Psalm it is pictured, the Bride is all glorious within: her clothing is of wrought gold. She shall be brought unto the King in raiment of needle work -- representing the Church all going into the Father's presence at the end of this age, and then we read in the next verse, "The virgins, her companions that followed her." These were the foolish virgins. They are virgins, nevertheless, that follow her. They also shall be brought into the presence of the King. We are glad for them also. There is no selfishness in the love of God. We are glad to see what the Lord has arranged for the Little Flock, the Great Company, and the Ancient Worthies, and for all the world of mankind -- for all who desire to be in harmony with Him when they come to a knowledge of the truth.

3. **QUESTION** -- Isaiah 40:1,2 "Comfort, comfort, ye my people, saith your God. Speak ye comfortably to Jerusalem, cry unto her that her warfare is accomplished, and her iniquity is pardoned; for she has received at the Lord's hand double for her sins." Do you consider this applicable to our attitude toward the Jews at the present time?

**ANSWER.** -- I would think that it would be proper enough for us to speak comfortably to Jerusalem, but I do not think it implies that Jerusalem is going to hear at first. Now we have spoken a good many comfortable things to the Jews. If you will take into consideration what is written in the 2nd volume of Dawn on the subject, and what is the future hope for the Jews, and in the 3rd volume calling attention to this very Scripture, and the booklet in the Hebrew jargon that gives the Tabernacle Shadows, and what we believe to be the true interpretation of the book of Hebrews, you will notice that we have tried to speak to the Hebrews some of these comforting words, but we have not found it has made very much impression on them -- perhaps a little, we do not know. But the Lord says the time is coming, and that those who have an ear to hear will hear, and the others that do not have an ear to hear will have to wait until the trumpet blows loud and long.

4. **Question** -- Please explain Luke 20:35, 36: "But they which shall be accounted worthy to obtain that world, and the resurrection from the dead, neither marry, nor are given in marriage;

neither can they die any more: for they are equal unto the angels; and are the children of God, being the children of the resurrection." Please explain the clause, "They can die no more, because they are like the angels."

"**Answer** -- This is the Common Version, translation version, which is preferred in this case. We do not prefer the Common Version every time, but we prefer it as a rule, to any other version which we know,

There are some passages upon which the Diaglott translation, and some upon which the Revised Version gives us more light, but taken as a whole, we like the Common Version. And the Common Version says, they are like unto the angels, neither can they die any more, and that is the way I think it is in-tended to be read and understood. My understanding is, this is applicable both to the Church and to the world. It is applicable to the Church first, because it is to be dealt with first. It is applicable to the Church in this way, that when the time comes for our change, and we have had our resurrection change, the first resurrection, the resurrection to glory, honor and immortality, that will make us children of the resurrection in a special sense, more than any others, be-cause this is the highest and everything else in the nature of a resurrection would necessarily be subservient to this which is the highest and most wonderful of all the resurrections God has purposed. There is one resurrection of the Church, and another of the ancient Worthies, to perfection, and then, as we saw last night, there is a resurrection to judgment for the world, by which they will gradually come into harmony with the Lord. But now, we will apply this first to the Church. When we have been changed and are spirit beings, we will not die any more; if we have immortality we cannot die any more. And we would be like the angels, for the angels do not marry; and so, in this respect, the Little Flock in the resurrection will not be male and female. While spoken of as the Bride of Christ, we are not to get the thought that they are feminine, but rather it is only a picture which represents the beautiful relationship between the Bridegroom and the Bride. And, again, we have the thought of Christ as the Head over the Body, and we as members of the Body, -- another beautiful picture. You know all of this represents our Lord as being the chief. Angels are not male and female, and in speaking of them we would not use those terms; we would prefer not to speak of them as either, because they are without sex. That is easy enough as respects the Church.

Now as to the world. When by the end of the Millennial age the world shall have come up, up, up, out of degredation and sin, and got back to the place where Adam was originally, then all necessity for the male and female condition in order for the propagation of the race having ceased, they will be like unto the angels in that respect. Originally Adam was not male or female, but God separated woman from his side, and made our race male and female; but after God's whole purpose has been served, and Christ has taken the place of that one man, and has redeemed all that came out of him, then the sex distinction, having served its purpose, will cease. Our understanding is that then the race will be like unto the angels in that respect. And neither will they die any more; they will be perfect. So when the race is brought back to perfection, and after all have been tested at the end of the Millennial age, as many as love righteousness will have everlasting life, and the balance will be destroyed from amongst the people. God is pleased that the righteous shall live forever and enjoy all of His blessings throughout eternity.

5. **QUESTION** -- On what grounds is it affirmed that our Lord's personal presence began in 1874 and will continue until the end of the Millennial Age?

**ANSWER.** -- I answer, it is based on this ground: that He comes to accomplish a work and that the work is, He must reign until He shall have put down all authority and all insubordination, and shall have brought everything into harmony with God, and shall have delivered up the Kingdom to God, even the Father. The Scriptures say that He must reign a thousand years. Therefore, we see that when His presence came in 1874 it was intended to last the whole thousand years. Now when we speak of it in that way, we do not mean to have it understood that the Lord must stand at one particular place on earth, or that He is to stand on the earth at all; because spirit beings do not need to have platforms, etc., to stand on. We are not to think of it as meaning that the Lord has a fixed place, and that He cannot get away from the earth. That is not the thought we wish to give at all. That is not our thought. Our thought is that our Lord came for the purpose of reigning, and He will not give up that purpose nor that work. He may go to and from the heavenly Father's presence, and the Church may also go to and from the heavenly Father's presence, but still their work is in connection with the earth, and this is their kingdom, just as President Roosevelt is supposed to be in this country while he is president of the country, yet he sometimes makes journeys to Cuba, or he may go to Panama, or somewhere else, and he has really gone out of the country yet in a sense he is still in the country, because, if he has gone to Panama, he has left certain persons to represent the presidential office in Washington; and he is still president whether he is in Washington or in Oyster Bay. So, with our Lord Jesus during all the Millennial Age; He will still be the reigning King of earth, just the same as we say now He has ascended up on high, there to appear in the presence of God for us. He is set down at the right hand of the majesty of God on High, but that does not mean that God is sitting in a great place and never moves from it, or that Jesus has sat down there and that he has not gone away all the time that he has been at the right hand of God's majesty, but in the sense that He is next to the Father; He is the one next in honor, and dignity to the Father, and He will always maintain that; He will be at the right hand of the Father when He is reigning as a King on the earth; as we say, speaking of the second coming of Christ, the Son of Man shall come in glory at the right hand of the Father. When He is coming in the clouds with great power and glory, He will be at the right hand of the Father all of that time.

6. **QUESTION** -- In Jude 7, referring to the Sodomites, does the word "eternal" properly qualify fire, or vengeance, or suffering, for example?

**ANSWER.** -- I would answer, it qualifies fire -- eternal fire suffering the vengeance of eternal fire; that is the way the translation gives it. I think it is all right. What kind of eternal fire was it? Did it keep on burning there, and if you could go to where Sodom was would you see it burning now? No. Well what kind of an eternal fire was it? It was a fire whose effects were eternal; it was not a fire that merely burned a little while and then went out, but it burned until it burned everything up. And so, when the Lord is going to destroy the wicked, He will destroy them with an eternal fire, that is, a fire that will be complete, and finish the work. It will not be destruction for a little while from which they will be recovered, but it will be the vengeance of utter, complete destruction. In your talk every day, if you will only think about it, you use a great many figures of speech. Every person who can talk uses a great many figures of speech; and in olden times, they seem to have used these more than we do today. They made all

languages in pictures. Some of the very old languages were all pictures, and all the spelling even was in pictures. Some of those old hieroglyphics that have been found in Egypt and elsewhere are all pictures. So our words are all pictures.

7. **QUESTION** -- Please explain the text that speaks of some persons as natural brute beasts made to be taken and destroyed.

**ANSWER.** -- The Apostle is speaking of some who are to suffer destruction at the hands of the Lord, and he says as wild beasts they are taken and destroyed. You do not think it any harm to destroy a lion. Why? Because he is ferocious and apt to do some harm. If it were a dove flying about and harmless, I would say, do not touch it, but let it go. Or if it were some bird of beautiful plumage flying about and doing no harm, but only uttering some beautiful trill of voice, I would say, do not touch the bird. Why should we destroy the life of any such innocent and beautiful creature? But if it were a lion or a tiger, and the whole village or city was in distress because of it, and it was going to do some harm, we would say that we had better destroy it. Every policeman under such circumstances, is authorized to draw his revolver and to shoot immediately. It is only fit for destruction; and is not a proper thing to let go at liberty. So, the Lord has this view with respecting a certain class He is going to destroy in the second death. They are not fit for life; that is the reason they will be destroyed. They are no more fit for life than the brute beasts are fit to live. Just as it is proper to destroy a corrupt person who has injured others, and to cut off his opportunity of perpetuating evil, so it would be to destroy a brute beast. And God purposes that all the wicked will He destroy -- those who have had full knowledge, and have been helped in every way that God, Christ and the Ancient Worthies will be able to help them -- after they have had all of that, if they are still, at heart, antagonistic to righteousness and if they still love iniquity, let them die as brute beasts. But it would not be right to torment them. It is not right to torment brute beasts. Who would say that God or man had a right to torment even brute beasts, or human creatures? But it is right to destroy beasts and it is right for God to destroy those who will ultimately be like brute beasts, in that they would be injurious to others.

8. **QUESTION** -- Isaiah 26:19 "Thy dead men shall live, together with my dead body shall they arise. Awake and sing, ye that dwell in the dust: for thy dew is as the dew of herbs and the earth shall cast out the dead." Does this imply that someone will be raised when the Lord's body was raised, or does it refer to the Lord at all?

**ANSWER** -- I understand it refers to the Lord, and the translation is nearly right, but there is just a little bit of difference, as you will notice in the Common Version, some of the words are supplied in italics. When it is properly translated, it would read: "Thy dead men shall live, my dead body shall come forth." We are the Lord's body, and as His body, we shall come forth; "The dead men shall live, my body shall come forth from the dead as the Body of Christ," as He did.

9. **QUESTION** -- How shall we understand this text: "For we must all appear before the judgment seat of Christ; that everyone may receive the things done in his body, according to that he hath done, whether it be good or bad?"

**ANSWER.** -- In one sense of the word we are all standing before the judgment seat of Christ now. Are we not on trial? Yes. Who is the one that is trying the Church? Jesus, as the Father's representative. All judgment is committed unto Him. And you remember how he tells the different churches that unless you hear My voice, etc., I will remove your candlestick out of its place. He was judging the Church, you see. When He comes to the Laodicean Church, He says, "Behold, I stand at the door and knock." The judging and testing is going on now. And if you hear my voice, I will come in and sup with you, etc. And so the Lord all the way down has been judging His people. We are in the school of Christ; He is our teacher, and instructor, and discipliner, and when we need to receive corrections, the Lord Jesus, as the Father's representative, attends to that matter.

**10. QUESTION** -- How may we overcome the horror of death?

**ANSWER.** -- I answer, dear friends, that God never intended that death should be a pleasant thing for us, and the wiser you are, the less you will like death, of itself; it will have more horror for you. The way to overcoming it is by full submission of our minds to the Lord. There are some things that we will never like all our lives. You might take a dose of very bitter medicine, and without making very many faces either, if you made up your mind that it was the right and proper thing to do. You would say, Well, I am going to do it and you do it; but if you allow yourself to go over it and look at it too long, and try to swallow it two or three times, you will get pretty sick of the matter. The right way to do is to say, it is the Lord's arrangement, and it is a part of my covenant to lay down my life in the Lord's service, even unto death; so Lord, I give the whole matter to you, I have taken the whole matter out of my hands entirely and I am reckoning myself dead now, so Lord I will leave the whole matter for you to bury me and for you to raise me up. The whole thing is in your hands. After you commit your way to the Lord, it will taste and feel far less bitter. While death and the dying processes are not to be rejoiced in, yet you are to realize the Lord's providential care, and that He is able to keep that which we have committed unto Him, and we should not sorrow as those who have no hope. We might sorrow some for death, but not as others, because we have the blessed hope; and the stronger your faith grows the less dread you will have of death; and the stronger your knowledge of your consecration becomes, the stronger your faith will be.

**11. QUESTION** -- "Train up a child in the way in which he ought to go, and when he is old he will not do part from it." Why do they so many times depart from the right way?

**ANSWER.** -- I think the principal reason is that they are not properly trained in the way in which they should go. I think people in the truth need a little lesson along the line of training children. Perhaps we have something that works to our disadvantage in the matter. The more your heart becomes large, and forgiving, and generous, the more you will forgive your friends, and your children, but you must remember that when dealing with your children, you are not dealing with them as with another man or woman; you must look at the character that is being formed, and you must, in line with the Lord's arrangements, bring discipline to bear so as to fashion that character in the way in which the Lord would have it go. If it is a crooked little twig, you must put on splints where it is crooked and help straighten it up, because if you allow it to grow up to be a big tree with those crooks, you can never put on splints that will straighten it out.

I think some of the friends are inclined to spare the rod, and do not notice what the Scriptures say. We are not to spare the rod when it is necessary. We are to take God's way in the matter. Does God spare the rod on you when it is necessary? By no means. "Thy rod and Thy staff, they comfort me." I am glad God has a rod and a staff for His people; glad that He does not let us go without correction, if we need it. But when we have the right spirit in the matter, we will feel more of a regret that we have need of the chastisement than the getting of the chastisement itself. The worst thing of the rod should be, "I am so sorry that I need to be chastised, and that I did not correct myself, or hold myself in the proper restraint." And that is what you want to cultivate in the child -- not that the child shall get a certain number of whippings, but that as children of God, it is your duty and responsibility, and you must whip it. I can count the whippings I got in my life on my fingers; I got just five, and I remember all about every one of them, and all the circumstances connected with them. I got three from my mother. I want to tell you about one of them. I was about five, as near as I can remember. Of course, I may have gotten some spankings when I was so small I did not know about it but when I was about five, I remember I got one. My mother taught me to the best of her knowledge. She had a pair of leather tawers that would bite at the end, but do no real harm. There were about six or eight tails to them -- "Their hurt was in their tails." "Charles, bring the tawers and come up stairs." So I carried the tawers up stairs. She said, now, sit down here and I will read to you out of the Bible. She thought I had prevaricated, or had twisted the truth; not that I had told a point-blank lie, but twisted the truth a little, as most children are inclined to do, especially if some older folks laugh at them and think they are smart; but I did not have anyone to laugh at me and think it was smart if I should do anything of that kind. I learned that that was not the way to do. So she read to me from Revelations all about those without, all the liars shall have their place with those who burn with fire and brimstone etc., and she said, "Charles, I do not want you to have your portion with those in the lake that burneth with fire and brimstone, and it is my duty, as your mother, to give you chastisement, and I must do it. I do not want to whip you, but I must do it for your good. This is the teaching of the Lord's Word, and this is what will happen if you should grow up to be a liar, and if you should grow up to become a bad man." You see how much impression that made on my mind, that little suggestion from the Scriptures. Of course, if she had understood the matter, she never would have made that application of the Scripture, but she could have found some other Scripture that would have been equally forcible, and perhaps more so. The fact that God has no use for liars can be very easily impressed on the mind of a child.

12. **QUESTION** -- In what respect will faith be required of the world in the Millennial Age?

**ANSWER.** -- Well, it is very difficult to explain that because there are so many different ideas as to what faith is. Now, if you are referring to faith as meaning a belief in the things that you do not see, and the things that you do not know, and the things that God has merely revealed to us in His Word, that kind of faith will be very limited indeed in the Millennial Age. Why? Because everything will be made so clear and manifest that it will not belong to faith, but it will then be sight. It is faith now because God is choosing a peculiar people, and He is testing those who have the hearing ear and the eye of faith, who can walk by faith and not by sight. And so He represents that we are walking in the narrow way, and the light is on our pathway, and by and by instead of having a pathway that is dark, and merely lighted as we take these steps, the Son of Righteousness will arise with healing in His beams. A man will not need to carry a lantern when the sun-light is shining. Just now, the lantern of God's Word, and the carrying of it, represents



our faith coming from it, but they will not need that in the Millennial Age, because knowledge will be everywhere, and instead of faith, knowledge will be required, and it will be possible for people to come to know all about God and about His plan. Is knowledge better than faith? Yes, indeed. Wouldn't you want absolute knowledge if you could get it? Yes, indeed. But you are now walking by faith, are you not? Yes. God says that is the way He wants us to do now, and He does not furnish any more than that now. He gives us enough knowledge to have a basis for our faith and does not give us anything stronger than would be a basis for faith.

**13. QUESTION** -- Please harmonize these verses: "The world cannot hate you, but Me it hateth because I testified of it that the works thereof are evil." And the other text is: "If ye were of the world, the world would love its own. Now, because ye are not of the world, but I have chosen you out of the world, therefore the world hateth you." Please harmonize these two particular texts, and particularly the words, "The world cannot hate you," and "therefore the world hateth you."

**ANSWER.** -- The one was spoken to a mixed audience of people, and the other was spoken to those who were His disciples, whom He had gathered out from the Jewish people. He said, Them that you gavest me, they received my Word and because they received My Word and became My footstep followers, therefore the world hates them because it hated Me. It did not hate them originally; it was not opposed to them originally. It might have ignored them, but it did not hate them. But He was bearing the light, and the light rebuked the darkness, and so they hated the light, and hated the light-bearer. Now you have become sharers with me in holding up the light -- "Let your light so shine" -- and in proportion as you do so, the world will hate you just as it hated Me.

**14. QUESTION** -- In God's Plan, what provision is made for the infants and children who die before the years of discretion? Are they confined to the earthly Kingdom?

**ANSWER.** -- I answer, dear friends, there is no way to the Heavenly Kingdom, except by being born again. Can children be born again? Can children be begotten of the Holy Spirit? If they could not be begotten of the Holy Spirit, they could not be born of the Holy Spirit; so you see, the whole matter is a very simple one. The child belongs to the earth; it belongs to Adam and his race; it is a member of his race. If God wished it to have had the opportunities of the elect, He would have allowed it to live and come to a knowledge of the truth, and thus to justification, sanctification and begetting of the spirit. But you see when the Lord allowed the child to die in infancy, it was not one of those whom He intended should be favored with a knowledge of this High Calling, and that is a large proportion of the race. Now, what will be their position? They will come forth as they went down, of the earth earthy. But some one will say, "If I belong to the spirit class, and of those who have part in either the Little Flock of the Great Company on the spirit plane, what chance would I have to care for my little ones?" Well, my dear brothers and sisters, do you not suppose your little ones will still be under supervision, as if you were an earthly parent? Do you not suppose that those heavenly ones, who are Kings and Priests with Jesus, and have all power in heaven and earth, will have power to take care of their little ones on earth? And there will be many who will be glad to take care of your little ones, they are serving those who have gone before, and who belong to the Priesthood class.

To our understanding, the coming back of these from the tomb will be in the same condition in which they died without any particular change, and the little ones, therefore will come back to much more favorable conditions than at the present time in the world.

15. **QUESTION** -- Some one has asked why we baptize in the name of the Father, and of the Son, and of the Holy Spirit, if the Holy Spirit is not a person?

**ANSWER.** -- First, that is the formula given in the Scriptures, and secondly, because it is the right thought. We do not baptize in our own name, or in the name of the Baptist Church, or in the name of some other church. But what authority do we recognize? Do we recognize the Father's authority and sanction to baptize? Yes, indeed. Do we recognize the Son's authority and sanction to baptism? Yes indeed. Do we recognize that the Spirit sanctions this matter of baptism? Yes, indeed. Well, then, we perform the baptism in the name of the Father, and the Son, and of the Holy Spirit as representing that which is the will of God, and in every sense the spirit of the Lord's will and teaching. The thought is, the matter of baptism is approved by the Lord Jesus approved by the Heavenly Father, and approved by the spirit of holiness, the spirit of God, the spirit of the truth.

16. **QUESTION** -- Does the first chapter in the New Testament lead us to conclude that God may have miraculously used Joseph as well as Mary in naturally bringing forth the perfect man Jesus from perfect, purified origin and nature?

**ANSWER.** -- I answer, no. It could not teach anything of the kind, and does not teach anything of the kind to my mind. The fact is, that if Jesus was a son of Joseph and Mary, He was just as much a son of Adam as you are and as I am, and He was just as much an inheritor of Adam's sin as you and I are, and if He was an inheritor of Adam's sin, He was just as much under the death sentence as you and I are, and if under the death sentence, He could not have redeemed Himself, let alone the world. So the Scriptures clearly teach that the Redeemer should be one whose life was not from the condemned source. But, as the Scriptures say, Jesus' life did come from the Father, and as He Himself said, He was with the Father before the world was, and as the first chapter of John says, "In the beginning was the Word, and the Word was with the God, and the Word was a God. The same was in the beginning with the God. Without Him was nothing made that was made!" Here the prehuman existence of our Lord is affirmed, and how He left the glory He had with the Father humbling Himself and did not stop, as says the Apostle Paul with the angelic nature, but stooped to the human nature and was born of the woman, not of the man. He was born under the Law that He might redeem the world. So the whole thing according to the Scriptures, sticks together. If we bring Joseph into it, we spoil the whole matter. Jesus could not be your Savior and mine, if Joseph had anything to do with His birth in any sense. I suggest that the one who made this question read in the fifth volume of Scripture Studies, the chapter, "The Undefined One."

17. **QUESTION** -- Will the incorrigible live more than one hundred years, or will they die at a hundred years of age?

**ANSWER.** -- Our understanding of that statement of Isaiah's testimony is that, the sinner at

that time, if he is a willful, deliberate opposer of God and his Kingdom, will not be suffered to live more than one hundred years. It does not guarantee that he must live a hundred years, but he must die at a hundred years. He may die sooner than a hundred years if sufficiently willful and disobedient, but he may prolong his life even if in a measure disobedient for one hundred years but no longer.

18. **QUESTION** -- Is it not reasonable to suppose that we may expect in due time an announcement through the TOWER that the door of opportunity for consecration is closed?

**ANSWER.** -- I think not. I see, dear friends, from different questions that come to me from different places, that thought is prevailing, and I may have been guilty of having started it for all I know. That is about the closing of the door. Now, everyone has a right to use language in his own way and as long as he keeps within certain bounds, no one can say he is talking amiss. So, we can talk about the door of opportunity closing, but I wish you to notice that the Bible does not speak of the door of opportunity closing. Undoubtedly there will come a time when the opportunity to spread the truth will be more or less hampered, when things will be greatly curtailed, and people, perhaps, who are opposed to us may try to make out that we are in some manner or form anarchists. The idea is growing that all anarchy should be put down, and we are in full sympathy with that. We think anarchists are unreasonable and unsafe people, and that they should be restrained. But we expect the time to come, not many years hence, when some will say of us, "You are anarchists, against the government, and against the Churches." And they will have power with the government, and there will be laws passed that will squeeze the anarchists, and then we will be squeezed in with them, so as to get rid of us to some extent. You might call that perhaps, in some sense, the closing of the door of opportunity to proclaim the truth. We know that cannot come until God is ready. In the meantime, we can expect that the truth is going to have a very wide circulation.

My expectation, dear friends, is different from that of a good many. I know some of the Lord's people are thinking the harvest work is about done now, but as I have been telling you for some years back that my understanding is the work is not nearly done; there is a whole lot more work to do. We had in the Watch Tower office about three years ago a change in our method of keeping the list of Tower subscribers from books to the card system. We had an arrangement made for holding the cards, and the question arose, how large we should make it. I said, We will make it large enough for fifty-five thousand. Some said, O, that is too large. No, I said, I think we are going to need most of that space for 55,000 subscribers to the Tower. Now, we have not yet got them, but we think they are going to come in. Our expectancy is there will be large numbers of people coming into a measure of the truth, and a measure of sympathy, and there are people in all the denominations who are true saints at heart, and have been more or less blinded and confused by churchianity, and they supposed things were more like what they saw on the outside as Jesus said about the scribes and Pharisees that people looked on the outside and saw that they were beautiful and whitewashed, and Jesus said that inwardly they were full of all manner of impurity. So the people of all denominations are beginning to wake up and look about them and say. What does this mean? Am I wrong? Am I so fanatical that I cannot be in sympathy with other people? It is not they that are wrong; it is the institutions that are wrong; and their hearts are searching for the Lord, for there is a famine, not for bread or for water, but for the hearing of the Word of the Lord. Some of this class are beginning to see that they are

hungry. Now we believe that class is everywhere within your reach and mine, and that the Lord is giving us a great privilege in hunting for them.

You remember that only in one place in the Scriptures do they speak of the door shutting, and that is in the parable of the wise and foolish virgins. And there it says, the Bridegroom came. We apply that to the year 1874, and this was called to the attention of the wise virgins, "Behold the Bridegroom" -- not behold the Bridegroom cometh, but behold the Bridegroom, as representing His presence, and then all the virgins arose and trimmed their lamps, and some of them had oil in their vessels as well as their lamps. Now, you know what the lamp is, and what the vessel is which carried the Holy Spirit. You must have both. If you are without oil, then something is wrong. You must get the oil or you cannot be one of the wise virgins, and you remember the wise virgins went with the Bridegroom in to the marriage and the door was shut. Now, that is the door of the parable. When did the door shut? After the wise virgins had gone in. What does that mean? It means after the last one of the Little Flock has made his calling and election sure, and has been tested sufficiently and has been passed as a successful one, and the high calling is ended, and the last one has gone beyond the veil, that the door is shut. That is the parable. Then afterwards came the other virgins, the foolish virgins, that had gotten oil in the in the meantime. Yes, they got the experience, and development and the knowledge, and the light, and then they came, and knocked and said, We are a little bit late, but let us in please. We heard about this, but we did not have the oil in our lamps. But, the answer comes, "I cannot recognize you. The whole company, the elect company, is all in. I cannot recognize you." What will they do? They will pass through the great time of trouble, as the parable shows, and there shall be weeping, and wailing, and gnashing of teeth. The time of trouble that will come on the whole world will cause a great amount of anguish, and disappointment, and sorrow, in these ways, represented by that familiar expression, weeping and gnashing of teeth.

**19. QUESTION** -- Are we begotten to the divine nature, or only to the spirit nature?

**ANSWER.** -- I answer that the begetting of the spirit is to the spirit nature, but in the case of our Lord, it is, must be, to the divine nature or nothing. Why? Because if He had failed to be more than a conqueror and worthy of the divine nature according to the divine plan, then He could not have been acceptable at all.

He could never have come into any secondary place. His begetting of the spirit must eventuate in the divine nature or nothing. But in the case of the church we may say it is a little different; that while our begetting is of the spirit, and while the Lord intends that this shall be the highest form of the spirit nature, if we are faithful and follow in the footsteps of the Lord, yet there will also be some of this class begotten of the spirit who will never reach the divine nature, but will be, so to speak, sidetracked from the divine nature; therefore, we prefer to put it that the church is begotten to the spirit nature, and some of them get beyond this to the divine nature. The Great Company will reach the spirit plane yet not be of the divine nature.

**20. QUESTION** -- Comparing the spiritual with the natural birth, what manifestations should we expect at the begetting and what at the quickening?

**ANSWER.** -- I would say that in comparing the spiritual begetting with the natural begetting,

we would not expect much of any kind of manifestation at the begetting. It is a fact that it does take place, and the demonstration is found later and so, if we are begotten of the Holy Spirit, we may have some consciousness of it, but the outward demonstration would not be very marked to anybody else; there would possibly be some manifestation to others; it would be the quickening, the energizing motion that would be the indication of a personal life. So when we are begotten of the Holy Spirit it quickens our mortal bodies, energizes us in the Lord's service, and we begin to have the love that moves and wants to serve God and the brethren, and to do good to all men as we have opportunity.

## 2:30 P.M. -- Discourse

by Brother J. A. Graham, of Boston, Mass.

**Topic: "Having Harps of God."**

"Have you heard the new song, that most beautiful song,  
The song which the Saints now may sing --  
How the old harp of Moses and the sweet flute of John  
With harmonious melody ring?

God's Word is that harp, which has long been unstrung,  
And men heard but discordant its notes;  
Now as tunes are its cords from Moses to John,  
How grandly sweet melody floats.

It will float o'er the world in a rapturous strain,  
Of glory and peace and good will,  
And all then shall hear and join the refrain  
And joy shall the hearts of all thrill."

DEAR FRIENDS, we have just sung a very beautiful hymn; I am sure we all enjoyed the singing of it, and doubtless we were very much refreshed in singing a few things about this harp of Moses. We hope, now, by the grace of God, to stir up your pure minds by way of remembrance in bringing to your minds some of the things we have found about the harp of God.

The harp, you know is used to make music -- harmony, melody, something sweet, something enchanting, something that will charm and please in every way. And I think that we may very profitably consider that this is the thing above all other things that we want to do with the harp which we have, and on which we make pleasant and sweet music, music that will charm.



Brother J. A. Graham.

We find in the Lord's Word that the harp is one of the very oldest, if indeed not the oldest, musical instrument, just as the Bible is the oldest book. We have the first record of a harp in Genesis 4:21, where it reads as follows: "And his brother's name was Jubal: he was the father of all such as handle the harp and organ." So we see, then, that the harp is a very old instrument, just as the Bible is a very old book.

Then again, passing along down to David's day, we find that David, so to speak, glorified the harp; he made perhaps the sweetest music on the harp of any of those ancient harpers. We find indeed David's harp was so versatile that almost every experience in life, almost every trial that the saints can have, almost every phase of the kingdom of God, almost every feature of the Plan of God, is touched upon by the sweet singer of Israel -- in the Psalms especially. A wonderful harp it was that David used and played upon.

Now the theme which we have given to us this afternoon is taken from the 15th chapter of Revelation, second verse, and it reads: "And I saw as it were a sea of glass mingled with fire: and them that had gotten the victory over the beast and over the image and over his mark, and over the number of his name." We notice here it says harps; it does not say harp; it is plural, more than one harp. They had harps of God. Now the Revelator mentions these harps again on another occasion, we think, in the beginning of his wonderful prophecy. He mentions these same harps in Revelation 5:8-10, and there we read as follows: "And he came and took the book out of the right hand of him that sat upon the throne. And when he had taken the book, the four beasts and four and twenty elders fell down before the Lamb, having everyone of them harps and golden vials full of odor, which are the prayers of the saints. And they sung a new song saying, thou art worthy to take the book and to open the seals thereof; for thou wast slain, and hast redeemed us to God by Thy blood out of every kindred, tongue, people and nation; and hast made us unto our God kings and priests: and we shall reign on the earth." Here we see there are twenty-four harps, for the Scriptures give us the thought that each one had a harp. So we find, then, these harps were twenty-four in number. Now, then, if we were to institute a search for these harps, where would we find them? We may begin with Moses. We just sung about the grand harp of Moses; his harp was a magnificent one, grand and glorious; the harmony there was something more than ordinary; it was not ragtime music that Moses got out of his harp, but he got something grand, and good, and glorious. It was measured meter. It was precise; it was in every way of the solemn, of the stately, solid character, the kind of music that stays with you, the kind of music that makes you enter into the spirit of the prayer, etc. So we find that Moses used one of these harps, and one of the grandest of the harps. Now we should not expect, of course, to look for literal harps. We were inclined at one time to think that if we could just have a harp, and have a sceptre, etc., but we are not now looking for such things. The harps of which we are speaking are not literal harps. In the 49th Psalm and 4th verse, we read: "I will incline mine ear to a parable; I will open my dark saying upon the harp." We may expect then to look for harps that speak, harps that may say something, harps where you will find some dark sayings spoken. So we may not look for literal harps, but for symbolic harps; and Moses' harp, we think, would be the first for which we would look.

Now we find that Moses spoke this wonderful music we suggested,--strong, stately, solemn and serious, telling of the power and wisdom of God in His creative work. There is nothing more wonderful in all the world than the brief, pointed, but nevertheless positive, statements of the prophet in telling of the creative work, and how all the zealous of the scientists falsely so-called, of this day have failed to shake the strain of Moses' harp in telling about the wonderful power and wisdom of God in His creative works. And we praise God that the more these scientists probe these matters, the more sure our foundation becomes, and the more positive we may be, and even those things uncertain at the present time, will be found to be in perfect harmony with

the grand harp of Moses, and that is what we may learn of God by having the harp, a study of any of the sciences will only result finally in corroborating the testimony of the beautiful harp of Moses, as he speaks of the power and wisdom of God in His creative work.

And then Moses tells a little more than that. He does not end his song upon the harp with the creative work, but he tells also about the wonderful justice and judgment of God in the law that He has given to us. We see in that law that exact justice is meted out to all, and will be meted out to all, and that there is no respecter of persons whatever before God; they will all stand alike before the great law of our Heavenly Father. How in contrast is the law of our land, for instance. We find there is very little of equity in the law. I have read that the people who founded this country started out all right with the thought of giving equity to all, but we find now that if a man steals a loaf of bread he is pretty sure to go to jail, and if he steals a million he is pretty sure to come out all right. But here is a grand law from which there will be no escape if we break it; it is tempered with mercy and love, and is just in every respect, and commendable to all of God's creatures. A wonderful song the prophet has given us on this harp in this respect.

But Moses sang of some other things besides the creative work, and besides giving this song of God's law; he spoke also of God's love, and mercy, and redemption, and perhaps he spoke in the most beautiful way possible in the types and shadows of the Tabernacle. No matter into how many languages the story of the tabernacle might be translated, the picture of the tabernacle itself could never be destroyed. So we see the Lord has wonderfully preserved these things to us, giving them to us in types and shadows, just as our Lord gave us many of His most important lessons in the parables, for the very same reason, in order that the real essence of the thing might be preserved for ever. For instance, take the parable of the wheat field. No matter how many languages you might translate that parable into, that wheat-field would be a wheat-field and the tares would always be tares, and so on, and each feature of that parable was presented much better indeed than had the Lord given us the language. And so it is in Moses giving us this wonderful picture of redemption. He has presented the whole matter, and in our day it shines with greater resplendence than it ever shone before. We thank God for this. We have not the time this afternoon, and it is not our intention, to speak about the particular matters that Moses mentioned in the Tabernacle, but merely want to speak in passing of the fact that Moses taught clearly the redemption, first of the Church, then of all the world of mankind through the Church, and its Head, exalted to be the Great High Priest which would stand forth in the beginning of the Millennial Age and bless all people under God's gracious arrangements. We thank God for Moses' harp.

And then coming down a step farther, not stopping to speak of all these harps, but just speaking of some of them, we come to the harp of David. Here, as we said a little while ago, is one of the most magnificent harps, one of the very grandest, and I do not know if we had not heard the strains of David's wonderful harp. How many experiences have we had in life where we have felt hopeless, and we have felt as though the Lord even had deserted us, and we went to this wonderfully sweet singer, and there found peace for our souls. We found indeed that the sweet singer had a song that suited our case, that fitted our experiences, and just helped us over the particular difficulty we had at the time, and showing the features of the plan. We find that nearly every feature of the plan of God has been touched on by the sweet singer of Israel. We find here all sorts of songs, every kind of song. You will find paens of glory, you will find glory songs,

you will find wedding marches, you will find chants, and you will find everything you can think of in this wonderful harp of David. David has spoken of them all. For instance that wonderful pastoral, "The Lord is my Shepherd, I shall not want," etc. What a refreshing it is; and how it has refreshed our hearts so many times! No matter how many times we read it, it comes to us with fresh beauty and fresh strength to our fainting souls, -- "The Lord is my Shepherd, I shall not want."

We said there was a wedding march there, and so there is; you will find it in the 45th Psalm. "Hearken O daughter, and consider, and incline thine ear; forget also thy own people and thy father's house; so shall the King desire thy beauty; for He is thy Lord; and worship thou Him. And the daughter of Tyre shall be there with a gift; even the rich among the people shall increase in thy favor. The king's daughter is all glorious within, her clothing is of wrought gold. She shall be brought unto the King in raiment of needle work; the virgins her companions that follow her shall be brought unto thee. With gladness and rejoicing they shall be brought; they shall enter into the King's palace." That is a wonderful wedding march, is it not -- a wedding march that has inspired all of our hearts, and we felt more and more that we wanted to be one of those of the Bride class, to be one of those who enter in with the Bridegroom, one of those the Lord shall count to be an overcomer.

Then, again, we have sad songs here in the Psalms, as well as joyful ones, and as well as wedding marches. So the Prophet says: "By the rivers of Babylon, there we sat down, yea we wept, when we remembered Zion. We hanged our harps upon the willows in the midst thereof." Some of us have done that; we cried, and felt bad and sick at heart when we looked at all of the abominations in there, and when we were obliged in many respects to support these, and lend our influence to them, not knowing which way to turn, or what to do. We, too, sat down and wept when we realized all the abominations that were done in Babylon. There by the rivers of Babylon we sat down and wept when we remembered Zion. We hanged our harps upon the willows thereof.

And there is a chant here, too: "God is our refuge and strength, a very present help in trouble; therefore will not we fear, though the earth be removed, and though the mountains be carried into the midst of the sea; though the waters roar, and be troubled, and the mountains shake with the swellings thereof. There is a river, the streams whereof shall make glad the city of God, the holy place of the Tabernacle of the Most High. God is in the midst of her, she shall not be moved; God shall help her and that right early."

And then we have a wonderful glory song. In the 17th Psalm, 15th verse, we read: "As for me, I will behold thy face in righteousness: I shall be satisfied when I awake in thy likeness." This is a wonderful glory song. It may be the basis for all the glory songs that may be written. It is the prayer of all God's consecrated children that they may be like Him, that they may indeed awake in His likeness. That is another grand and glorious victory song there. The Psalmist says: "Who is this King of Glory? The Lord, strong and mighty, the Lord mighty in battle. Lift up your heads, O ye gates; even lift them up, ye everlasting doors; and the King of Glory shall come in. Who is this King of Glory? The Lord of Hosts, He is the King of Glory." (Psalms 24:7-10.) That is a wonderful victory song. It shows us, dear friends, if we read all of the song, that by and by there is coming a day when the Lord will be God over all of the nations, tongues and languages,



when He will be indeed the Lord of the earth, when He will indeed be the very God to all of His creatures.

But perhaps that is enough of David's harp for this time. Then there are some other harps. Take the harp of Isaiah; he had a harp and made wonderful music on that harp. Sometimes, you know the masters become somewhat excited -- "agitata," I believe the musicians call it. They get very much agitated. He got very much agitated when he saw the shams of the people, the prophets and the priests. He flings away those shams and exposes them. Then farther over he tells about God's sufferings. Is there a place in the whole Bible where in a few words our Lord is pictured any better than in the 53rd chapter of Isaiah? No. And then he passes on, after telling of the sufferings of God's faithful servant, our Lord Jesus, and tells us of the glory that shall come; he tells of the victory that shall come to him, when indeed he shall see the travail of his soul and be satisfied. More than that, he tells us that the Lord will grant some things to the strong ones, who during this Gospel age, in the strength of God, have become overcomers, as indeed he was. And then he speaks about the victory of the Church: "Arise and shine; for thy light has come, and the glory of the Lord has risen upon thee." (Isaiah 60:1.) You know Isaiah tells a great deal about the Lamb of God and the sacrifice which he made. We are not to forget that all of these prophecies, all of these harps, speak of the sacrifice of our Lord Jesus Christ. That was one of the essential features of our Lord's arrangement. What a wonderful harp that was that Isaiah had. Could we get along without Isaiah's harp? No. In order to have a perfect orchestration, we need Isaiah's harp, and we need to give it a very prominent place.

Now we see also, that Ezekiel had a harp and Jeremiah had a harp, and then Daniel had a harp, and all the different prophets, the minor prophets, as we speak of them sometimes, had some beautiful harps. We have not time this afternoon, I am sure, to speak at all about these special harps, and of the particular kind of music that each one of them made, but it was all grand, glorious and harmonious, and we notice that a great deal of the music of these harps was not understood until the slain Lamb took the book, as the Scriptures put it, you know. I will go back and read the 8th verse of the 5th chapter of Revelations. "And when he had taken the book, the four beasts and the four and twenty elders fell down before the lamb, having everyone of them harps and golden vials full of odors, which are the prayers of the saints. And they sung a new song." It is very evident that all of these harps were very much misunderstood, and indeed were not quite clear until after the slain lamb took the book. Indeed we may say that in some sense they were in process of preparation only; that during that time Moses was preparing his harp, and David was preparing his harp, and Jeremiah his harp, and so with all of the others, each preparing his harp against the day that the slain Lamb should take the book, and then these various harps would be awakened into strains of glorious and grand music. And so we find that was the case; we find the Jews did not understand anything about the prophecies. We find the Prophets did not understand the things which they uttered. We find they were told that the things which they spoke did not belong to themselves, but that they did belong to us who should be heirs of salvation. We find also that our Lord, previous to His death and resurrection, did not see all of the features that were marked out in these harps, all these strains of music, as clearly as He did afterwards, and we see indeed that the Apostles did not understand; it was not possible for them to understand, until after the death of our Lord and His resurrection to glory. And then we see that our Lord was able to take them aside, and show them out of the Psalms, and out of the Law, and out of the Prophets, the things concerning Himself, how that Christ should suffer and

enter into His glory. And so, it says here that it was a new song. Another translation says, a new kind of song. And what was the song? It was the worthiness of the Lamb. "Thou art worthy to take the book and open the seals thereof: for thou wast slain, and hast redeemed us to God by Thy blood out of every kindred, tongue and people and nation; and hast made us unto our God kings and priests, and we shall reign on the earth. It was a song of the worthiness of the Lamb, a song that was begun at that time, and has been growing in volume, and we believe will continue in volume until it includes all the tongues and nations and languages of the whole wide world. What a wonderful song that was! It was a song of the worthiness of the Lamb.

Now we notice that this new kind of song was sung by all the prophets; it was sung by Moses, by David and by all the prophets; one after the other, they had something to do with the preparing of this wonderful song. In some way these were all silent until after the slain Lamb had taken the power.

And then, again, we find another Scripture which says that God by the prophets gave witness to Him that through faith in His name, redemption should come to the whole world of mankind. And so we see that this new song is the Song of the Lamb. It is the song of the joint-heirs of the Lamb, as well as of the Lamb, and the verses concluding tell us: "Thou hast redeemed us to God by Thy blood out of every kindred, and tongue, and people, and nation; and hast made us unto our God kings and priests: and we shall reign on the earth." It is the song of the kings and priests, then, as well as the song of the Lamb. They take up the same strain; they begin to make the same music out of the harp that the Lord had made, and the Apostles had made, and so it is the song of the joint-heirs of our Lord; it is the song of these kings and priests.

Coming to the Scriptures, we find them very strong on this point. We find the harp has played many strains along this line, showing that during this Gospel Age the Lord is by His mercy preparing certain heirs, joint-heirs with Jesus Christ, that they shall be associated with Him in the grand work of blessing mankind, that they may have a share with Him in His glory, that they are to be with Him and to see Him as He is; they are to be forever with the Lord. All of these precious promises, as the Scriptures tell us, God has given to us. Unto us are given exceeding great and precious promises that by means of these we might become partakers of the divine nature.

We see, dear friends, our harps have a great many minor strains. They are written in a minor key; they tell of some sadness, some sufferings, some sorrow, some trials that will be necessary for these joint-heirs, before they will be adjudged worthy of the joint-heirship, before they will be adjudged worthy of being associated with their Savior in the kingdom work, and before they would be adjudged worthy of participating in the divine nature as the heirs of God and the joint-heirs of Jesus Christ. We see, then, there have been some minor strains. The minor strains speak of sadness, but there are some people who are unlike musicians. You never heard of a musician who wrote always in a minor key. No, he does not do that, but he introduces some minor strains sometimes; because they are very pleasing and beautiful. No one ever heard of a musician who always wrote in a minor key. But we find some of the Lord's dear people who, somehow or other, seem to get their voices keyed in the minor strain all the time; they always have exceeding great and hard difficulties to overcome; they always have a great many trials; they always have the worst kind of trials, and they always are suffering some great and terrible things, undergoing

these severe testings, etc. Everything that comes to them is a test; they are always having tests, and some of them have so little joy that it is hardly worth speaking of. All of these you see are along one line, in the minor key. We thank God, however, that there are some of these minor strains in these harps. The Apostle tells us that we are to rejoice when we can suffer for Him, we are to rejoice when we fall into divers temptations; we are not to consider these things strange; we are not to consider that something unusual had occurred to us, but on the other hand, instead of being in the doleful lay, if we have trials, let us rejoice that it is because God desires to fit us for a place in the kingdom; it is because God desires to make us heirs of God and joint-heirs with Jesus Christ, to make us fit for the inheritance of the saints in light. And instead of talking, and dwelling, and making a song of these trials, let us turn the song the other way; let us rejoice and make it, not a doleful song, but a song of rejoicing all the day long that the Lord has considered us worthy to suffer for His name's sake.

Now the Revelator speaks of this thing again on another occasion -- Rev. 14:1-5: "And I looked, and lo, a Lamb stood on the Mount Zion, and with Him an hundred forty and four thousand, having His Father's name written in their foreheads. And I heard a voice from heaven, as the voice of many waters, and as the voice of a great thunder: and I heard the voice of harpers harping with their harps: and they sung as it were a new song before the throne, and before the four beasts and before the elders: and no man could learn that song but the hundred forty and four thousand, which were redeemed from the earth. These are they which were not defiled with women; for they are virgins. These are they which follow the Lamb whithersoever He goeth. These were redeemed from among men, being the first fruits unto God and to the Lamb. And in their mouth was found no guile: for they are without fault before the throne of God." Here we have, instead of twenty-four players, playing on their harps, one hundred and forty-four thousand harpers, and apparently they are all joined in one grand orchestra, as it were, and we may rest assured that each one must see to it that his harp is tuned. Now you know in an orchestra a good leader knows the moment any one of the players has an instrument that is out of tune, and sometimes their ears are so keen they will point out just the one, and tell him that his particular instrument is out of tune. Now, dear brothers and sisters, we want to be in this grand orchestra, and we trust that we are; we are striving to be; we have desired to be. So let us see to it that our harps are in tune with all the other harps. Now it tells us here that nobody could learn this song, except the hundred and forty-four thousand, so we can see that it is a particularly hard tune to learn, a particularly hard song to commit to memory, something that would be very difficult of accomplishment. And because of this doubtless only the one hundred and forty-four thousand have been sufficiently patient under the leadership of the Great Musician, the greatest of all the harpers, or have been sufficiently diligent to learn. Or the others have lacked in some respects in zeal in pushing their musical studies, and the consequence is that they have their harps out of tune with all the balance of the harps, and something has gone wrong with them. Now, on the other hand, we may rest assured that nothing could go wrong with the harp really; we find the harp to be the Lord's Word. All of these grand prophecies together constitute the great harp of God, and there is nothing the matter with the harp. There has been something the matter with its use. We have been told by the Prophets indeed that our harps were hung on the willows. We may understand that during the great wilderness pilgrimage of the Church during the dark ages, and even until the opening of the last century, their harps were hung on the willows and there was very little music gotten out of them. There was no trouble with the harp all the way along; the harp was simply placed on the willows and God's people were caused to weep, etc. The harp was

all right; the trouble was with the people that undertook to make the music upon it; they made some very discordant music; there was no harmony or beauty in it; nothing in it to be desired; it repelled a great many people. Thousands of people refused to believe the Gospel because it was so misrepresented by those who were unskilled in the use of this harp, and instead of bringing out grand and glorious harmony, they brought out just the reverse. We knew something about the confusion and turmoil that resulted from the preaching of false doctrines from this harp. But the song which we sometimes sing tells us that this harp has been tuned for us. You perhaps remember that wonderful hymn.

Your harps, ye tearful saints,  
Down from the willows take;  
No more by Bab'lons streams sit down  
And weep for Zion's sake.

The Spirit of our God  
Hath tuned the harp divine,  
And now, in grandest harmony,  
Its melodies combine.

Awake its notes of joy  
That tell of Zion's peace,  
And how, through everlasting years,  
Her glory shall increase.

Take down the harp divine  
Sweep o'er its many strings;  
They call to Zion, Rise and shine  
Thy God of salvation brings.

We are living in the time the Spirit of God has tuned that harp for us, and we can therefore begin to make grand music upon it. We can see indeed that the very best harp in the world would be spoiled by unskilled fingers, no matter how good the harp would be. It would be spoiled, and the music would be spoiled, by unskilled fingers. We must first learn how to use the glorious music from it, and so the Apostle tells us that we must study to show ourselves approved unto God, that we need not be ashamed, rightly dividing the Word of Truth. We must learn then, or we had better leave the harp alone until we learn something about how to sweep across its many strings, and then we may begin to play a little on it. It is better, perhaps, to let somebody else make the music if we have not learned to make music on it. How many of God's people in endeavoring to call attention to some that they meet from time to time to these glorious and grand truths have rather made a mess of the music, and spoiled the harmony and melody, because of their lack of skill, and lack of adaptability, perhaps. How much better it would have been to let somebody else give them the music. How much better, in other words, it would have been to just pass a tract along than to spend so much time talking ourselves, when, perhaps, we were not skillful in the use of the harp, not skillful enough in the use of the Word of the Lord to be successful in this attempt to lead the Lord's people.

In this 15th chapter and the 3rd verse, the Prophet tells us some more about this song. He tells us that it is the song of Moses as well as the song of the Lamb. We see that there are two songs, as it were, or we might call it one song with two movements, and so we have the song of Moses and the song of the Lamb. We have just pointed out briefly what the song of the Lamb is. It is the song of the worthiness of the Lamb; it is the worthiness of the slain Lamb to take the book and to redeem out of every tongue, kindred and nation and people. It is the song of the joint-heirs of our Savior Jesus Christ. It is the song, indeed, that speaks of the sufferings with Him now, and if so be we suffer with Him, we shall be glorified together with him.

Just briefly now, we will ask, What is the song of Moses? The song of Moses is the song of Restitution. The song of Moses is the song of the redemption of all through the precious blood of Jesus Christ; it is the song that sings of the grand and glorious times when the Son of Man shall be lifted up, and when all men shall see Him. It sings of the time when all men shall understand, when all shall know the Lord from the least to the greatest. It seems that every prophet has sung of this song, so the Apostle Peter tells us that Moses and all the prophets, everyone that has spoken at all has spoken concerning these great, and grand, and glorious restitution times. You notice this song is put first, the song of Moses. It was prepared first without a doubt, and I presume that we first got hold of the thought that we had ourselves been saved by the precious blood of Jesus Christ. And next, that the mercy of God is to extend to every creature. The most beautiful thing to our hearts has been this song of restitution. How it has rejoiced our hearts to know that God is so loving, and so good, and so merciful, and so just as to provide not only a salvation for you and for me, a salvation for the Church during this Gospel Age, but that He has provided a salvation as broad as the fall, and which will reach in due time all of the fallen race. How we thank God for that! What a wonderful song the song of Moses is, the song of Restitution!

I wish to say a little more about another feature; the Apostle tells us about another kind of song. He tells us we should do some singing ourselves. He tells us that we should have some songs of our own. He tells us that we should be able to do some singing, and make some melody in our hearts. Now these tunes we have been talking about, the song of Moses and the song of the Lamb, very largely, appeal to our heart, to our intelligence, to our mind; and now we have been making music in this respect. We have outside the discordant songs of Babylon, but we would rather sing the songs of Zion, those of harmony and beauty. The Apostle wants us to make some melody in our hearts. And how are we going to do that? We can realize that He wants us to do His will. If we find in our hearts a disposition not to do His will, if we are rebellious, we find indeed there is a lack of harmony, the song is not a grand and glorious song; and we find that if we cannot entertain a spirit of love toward all of God's people, and toward all mankind and toward our enemies even, as we pointed out this morning in one of the questions, then there is turmoil in the heart; there is not a peaceable condition, there is not grand and harmonious melody there. It is only when we are filled with the Spirit of God that we can make melody in our hearts, as well as make melody on this harp which we have.

Then again, we must realize that we do not want to do as some people do. They play one tune all the time. We have some seventh-day friends that do that, and some holiness friends that do that, and I am sorry to say, some friends in the truth that do that all the time. They play one tune constantly to the neglect of the others. Dear friends, let us remember that the Lord wants us to be

broad-minded and moderate in all things; He wants us to take a broad view of the whole matter, and that we should broaden our hearts and our minds by getting the whole tune, and all of the tunes, and all of the harmony that is in the Lord's Word.

Then again, some of the Lord's people are inclined to play a doleful song all the time. To me that is one of the strangest things. I cannot quite understand how any of the dear Lord's people should want to try to produce any doleful music upon this harp. Above all other things, if we read the Scriptures aright, we ought to rejoice. The Apostle tells us over and over, rejoice, rejoice, and again I say, rejoice, rejoice, and I trust, dear friends, that the melody and harmony of this grand harp that we have been learning about now for a good many years has so filled our hearts with sweetness and melody that our lives will be a grand and glorious song, that we will feel indeed that the harmony which we are making in our hearts is in unison with the harmony and melody which is made on all of these harps, the harps of Moses and David and all the prophets, and the whole Word of God taken together, and that it will all be one grand harmony. Our hearts and minds co-attesting with the Spirit of the Lord, as found in His Word. Amen.

### **7:30 P.M. -- Song**

*by Brother John T. Read, of Chicago. "I have Found a Friend."*

### **Discourse**

by Brother C. E. Fowler,  
**of Washington, D.C., on the subject of "Overcoming -- What? How?"**

BROTHER FOWLER spoke, in substance, as follows:

We suggest, dear friends, as a basis for our remarks this evening, the words of the Apostle John in his epistle, fifth chapter and fourth verse: "For whatsoever is born of God overcometh the world: and this is the victory that overcometh the world, even your faith."



Brother C. E. Fowler.

We believe, dear friends, there is no subject that could be of greater importance to us than the subject of overcoming, and yet we understand from the words of the Apostle that overcoming, with its privileges and promises pertaining to overcoming, is entirely limited to those that are begotten of God. So, we perceive at once that the efforts of the worldly to put away sin, and the filthiness of the flesh, however commendable it might be, we cannot class with the Christian's overcoming. The Scriptures reveal to us the fact that Satan is engaged in a warfare against the Saints, that he has at his command thoroughly organized forces, and the world, the evil spirits, and also our own fallen flesh, constitute the great enemy we have to combat. This is not the position of the world. We might illustrate their position in this way: You all remember the recent war between Russia and

Japan. During the time of that war, a certain part of Manchuria was under the control of the Russian army. Suppose some citizen of this country had gone there and got within the lines of the army. He might have been arrested; he might have been questioned by the Russians, but he would not have been seriously molested; he would have perhaps been permitted to go on his

way, after having satisfied them that he was not engaged in any operations against them. But suppose some one else had gone there, and was garbed in the uniform of a Japanese soldier, and had all the resemblance of a Japanese soldier; he would have been quickly arrested and put to death. Why? Because they would recognize at once that he was an enemy to their cause. And so, we find, dear friends, that Satan very quickly and readily recognizes those who are enemies of his cause, those who have sworn allegiance to the Heavenly King, those who have been robed with the robe of Christ's righteousness, those who have put on the raiment furnished them by our Lord, and who have equipped themselves for warfare; they become the special marks of the great adversary of our souls. We perceive, then, that the great conflict we have is as new creatures, begotten of the Holy Spirit. It seems to me that it would be entirely unnecessary this evening to present to you the various steps by which we attain to this great privilege. You are all aware how we must first be justified by believing in the redemption that is provided for us in the death and resurrection of our Lord and Savior Jesus Christ, and how that we must then present ourselves living sacrifices. But I would like to emphasize one thought in this connection, and that is, how our Heavenly Father looks on those who have taken this step. When we surrender our wills, when we want to do what the Apostle says, "Lo, I come to thy will O God," then, to all intents and purposes, we actually experience from God's standpoint, death. Indeed, to us it is a reckoned condition, but from God's standpoint it is just as real as when the undertaker comes and carries off the corpse. Then it is that this newly begotten condition takes hold of this old body, and energizes it, so that what was once the servant of sin, now, under the influence of the Holy Spirit of God, taking possession of it, giving us, as it were, a new mind, becomes the servant of righteousness.

Dear friends, we believe that here are a great many who fail in their efforts to overcome because they lack the decision and knowledge necessary. We cannot overcome successfully, we cannot fight successfully, unless we appreciate the tactics of the foe that we have to oppose. Those of you who are familiar with American history know that in the old French and Indian war, the battle of Duquesne was lost because the British, under General Braddock, were not acquainted with the tactics and methods of warfare of the American Indian. We can see that it is absolutely necessary for us to understand the methods of our foes; and you recall the words of the Apostle, "We are not ignorant of his devices." We understand the methods of our adversary, but we can only understand his methods by the study of God's Word which reveals them to us, in order that we, under God's leadership, may come off more than conquerors in this great warfare in which we are engaged.

We understand, again, dear friends, that while it is true that Satan uses the world in their ignorance to oppose our course, and their influence which is contrary to ours, and while he uses our fallen flesh to the same end, to thwart us, nevertheless Satan himself is the great leader of all these forces against us. And so, first of all, we want to estimate all the forces we have that we can bring against him. Our Lord spoke once in this way: that a king going to war would first consult if he could with a certain number overcome a still greater force coming against him, lest while the enemy was at a distance he would have to send an embassy and seek terms of peace. So, dear friends, when we begin to estimate how large a force to bring against our great adversary, do not let us make the mistake of counting ourselves alone, but rather, in the language of the prophet, understand that the battle is not ours but God's, that He who is for us is more than all that can be against us.

The Apostle Peter tells us, you will recall, how that Satan goeth about as a roaring lion seeking whom he may devour, whom resist steadfast in the faith. This gives us a clue, at least, as to one of Satan's methods of attacks. It is an attack against our faith. We find that the various false doctrines springing up are coined especially by Satan, and under his directions, for the purpose of frustrating our attempts to overcome, for the purpose of frustrating those who are seeking to do the Lord's will. And so it is important that we should be able to guard against these attacks, and that we have our faith well grounded to the ransom, the only foundation that can be laid. In the words of the Apostle Paul, we are admonished to examine ourselves, whether or not we be in the faith.

You remember that the Apostle in presenting this figure to us, not only suggested that these attacks would be along the lines of our faith, but he also presents a very beautiful figure, and perhaps we might draw some lesson from this. The lion, you remember, in his haunts goes out to seek his prey at the water courses where the animals on which he preys come to drink at the brook. Now, dear friends, we are all drinking at the brook. Our Lord drank at the brook, and we are drinking at that same brook; we are drinking of the waters of truth; but this drinking of the brook not only suggests the drinking of the water of truth, but also suggests the persecution which accompanies it. Our Lord, you remember, on one occasion told us how that after the good word of God had found lodgment in our hearts, Satan comes and snatches it away. But how does he snatch it away? Does he do it in a physical sense, as the words we might think imply? No, he does it by instilling doubts in our mind. We have all been here feasting on the good things the Lord has been providing. We have heard numerous sermons, beautiful presentations of the truth. How many have had doubts instilled in their minds? How many have fortified themselves against the machinations of the adversary that would steal, as it were, these helpful, these absolutely necessary words, from us? Dear friends, there is only one way to successfully combat these attacks of the adversary, and that is suggested by the Apostle Paul, to put on the whole armour of God. It is impossible to overcome, dear friends, in this time in which we are now living, unless we do this. It is impossible for us to overcome and to successfully combat the attacks of the adversary unless we avail ourselves of the privileges at our disposal, the privilege of knowing completely and perfectly the divine plan of salvation, an entire consecration to His service, and to be familiar and adept in the use of the Sword of the Spirit. It is impossible for us to do this unless we are humble and faithfully devoted in our service.

But the Apostle Paul suggests another line of attack of the adversary. Some of us might say, Oh, I am perfectly secure against these; there is nothing whatever that can shake my faith in the plan that has found lodgment in my heart; there is nothing that can shake my faith in that; I am perfectly secure. Satan knows where to attack our faith along those lines. But, dear friends, the Apostle Paul suggests that the adversary attacks people along various lines, and he tells us that we are not ignorant of his devices. The context shows that on some previous occasion in the Corinthian Church, there was one who had gone entirely astray from the path apparently, and been guilty of some offense, and Paul had written them that they withdraw fellowship from him in order that he might be ashamed of his evil course and repent and be brought back in a repentant and humble attitude of mind. And it appears that the treatment had the desired effect; it seems that the brother had repented from his course, but the Corinthian Church refused to receive him back, refused to forgive him, so Paul wrote to them instructing them to receive this one



back, showing how he himself, for Christ's sake, had forgiven him, and he said, lest Satan take advantage of us, for we are not ignorant of his devices. What does he mean by that? Why, he means that Satan comes as an angel of light. He would paint to you the glories of the cause we have espoused, and paint in the blackest hues the crimes this brother had committed, saying, you would besmirch the cause if you would show any sympathy or receive this brother back again, no matter how repentant he might be; it would bring ignominy and shame on the cause. Turn your back to him, receive him not again, you cannot afford to belittle the cause in this way. But, says the Apostle we have forgiven him for Christ's sake; and he besought them also to do the same, lest this one be swallowed up by over much sorrow.

So, dear friends, this is another way in which Satan attacks God's people, by bringing these charges against his brethren; he is the great accuser of our brethren, who has accused them day and night, but we want to make sure that we are on the other side, the excusers. I have heard of some of our dear friends in some places saying that they knew that such and such a person was undergoing severe trials, and they believed that God was chastening them for some offense which they were conscious of, but they would not extend a helping hand to them, they would not extend any sympathy to them. Why? Because they did not want to frustrate God's work in chastening him. They are not aware of the fact that God has not committed any chastening to us, but the Father chasteneth whomsoever He loves and receives, but He has told us to assume a forgiving spirit, to receive those who repent back into fellowship, and to excuse them after repentance. So, dear friends, let us guard against this attack of the adversary by cultivating this beautiful spirit of love, which is one of the most beautiful spirits, and which is indeed one of the severest tests that is coming on the Church in the end of this age.

But not alone does Satan attack the dear saints in that way, but through worldly influences. You know that the poor old world, because of Adam's fall, is entirely out of course. It is under the control of the Evil One, and you know that all of its efforts and all of its designs, and its ambitions, are entirely contrary to the hope we have, and to the course of sacrifice we have adopted; so when they see how we are sacrificing, how we are endeavoring to walk in newness of life, they cannot appreciate the step we have taken; they cannot understand, as the Apostle expresses it, how it is that we do not run the same course of excesses that, perhaps, unfortunately, we did, but they see that we are walking in a different way, and of necessity this brings upon us a certain amount of reproach in their eyes. Doubtless you remember in the Tabernacle service a certain number of animals were burned without the camp, and we have learned what that represents; and the world looks on our sacrifice as a stench in their nostrils; they cannot appreciate the sacrifice we are making; they say we are throwing away golden opportunities; that some of us might have made great marks in the world if we had adopted a different course; that we are losing opportunities to become good business men; that our social and financial positions are at stake. But we have cast these aside, and have adopted the course of following the lowly Nazarene in his footsteps, whithersoever He leads, and they cannot understand that, and as a result they do not extend us the sympathy which we would perhaps appreciate. But, dear friends, if they would extend to us sympathy, it would perhaps be very dangerous for us. So we realize that our fallen flesh is our great enemy also and that through our fallen flesh and contact with the worldly, it seems to be a sort of magnet which attracts the worldly condition, and it attracts us, as it were, momentarily from our course. We have to guard against these attacks and the influence of the world, and then it is that we have to and do sorrow

because we have been influenced by our associations. No wonder the Apostle wants us then, not to forget the assembling ourselves together, the more so as we see the day approaching.

Now, dear friends, if we are in that very day, the very trial times the apostle pointed to, we see how detrimental these influences of the world would be to us; we see how necessary it is then that we gather in the closest bonds of friendship with all those of like precious faith. As we see that our course is bringing upon us a certain amount of loss from a worldly standpoint, and brings on us a certain amount of reproach what is necessary that we overcome on this point? The words of our text suggest what is necessary: "This is the victory that overcomes the world, even your faith." Faith in what? Faith in the ransom of our Lord Jesus. Yes, and more than that, faith in God's promises, faith that all things work together for good to those that love God; faith in God's provisions for us; faith in the promises that pertain to our present conditions, and also that hold out for us the hope of glory at the end of this time of sacrifice. I fancy that more of the Lord's people are falling along this line of faith than along the line of casting aside the sacrifice. I fancy that many of us retard our own efforts towards overcoming by not sufficiently laying hold on this wonderful provision that God has made for us. So we want to realize that the Apostle Peter spoke a great truth when he saith that God has given unto us all things that pertain unto life and godliness.

Our brother told us this morning that it would be absolutely impossible for us to become joint-heirs in the kingdom unless we built a character suitable for that. God is not going to entrust the riches of the divine nature, the indestructible nature, to anyone who is not fit to exercise it properly. He is not going to give to any one of us these inestimable blessings until we prove that we are in sufficient harmony with His plan, and until we have proven our loyalty to Him; more than that, until our characters have been crystallized into a firmness or condition that the trials which might come at any future time would not cause the slightest deflection from the proper course. So we can see that it is these deflections we have to battle against at the present time. We are in the midst of the conflict now. There is no possibility of our overcoming in the future unless we begin right. And how must we begin right? Dear friends, when we first take the step of consecration, we must first realize the step, and that we have placed our intentions, our wills, etc., at the mark of perfection, and say, I would not do or say one thing less than perfect if it were possible for me to do it that way. I am not satisfied with less than perfection. And so, dear friends, to our understanding, it is not the work before us of getting our hearts right, but rather the keeping of our hearts right. Keep thy heart with all diligence, says the Wise Man, for out of it are the issues of life. We must have gotten our hearts right at the moment of consecration, for God would not accept anything less than perfection at the time of consecration; and so, dear friends, that which separates us from doing perfectly the Lord's will must not be the condition of our hearts, or the condition of our wills, but it must be simply the imperfections of the flesh; these weaknesses we have are nothing more than that. The robe of Christ's righteousness was not provided for the covering of our wills, it was provided to make up for the weaknesses that we have inherited from Father Adam. There is no excuse for any of us not having perfect intentions. We must set our intentions, our wills, and must keep them, at the one hundred mark of perfection. So, dear friends, just as long as we are endeavoring to put into execution our noble aspirations, we find with the apostle of old that that which we would do, we cannot do as we would. Why? Because, as he says, in my flesh dwelleth no good thing. It is this poor weak vessel we have to work through, and which the new mind has taken possession of; it is an imperfect

vessel. It has to work through an imperfect medium, and the result is, an imperfect work; but so long as our intentions are at that one hundred per cent mark, God's provision for us is that the righteousness of Christ is fulfilled in those who walk, not after the flesh but after the spirit.

Now, dear friends, in our efforts to overcome the weaknesses of the flesh, which we understand to be the third feature of our Adversary's stronghold, his great fort against us, let us understand the matter completely. Let us see the position the consecrated ones are in. We might illustrate it: let us suppose for a moment the saints in their consecrated condition represent a city; that this city was besieged; there was a great force coming from the land against it, and another great force coming against it from the water, and there was a state of insurrection within. Let us suppose the land forces represent the world, and the forces from the sea represent Satan and his followers, the fallen angels, supporting his cause. Let us suppose the insurrection within represented the flesh. What condition is that city in? Why any one familiar with warfare would know that that city was in a deplorable condition. They would say, there is no hope for it. Why? Because there is no loyalty within, and what would be the very first step to take? Why, any one acquainted with warfare would know that the very first thing to do would be to overcome and subdue the rebellion within. And so, dear friends, that is the first step in our attempt at overcoming. We must grapple with this enemy within, and we must remember that the greatest enemy of all is that one which is constantly with us. We can resist the Devil, as the Apostle says, and he will flee from us. We can separate ourselves to some extent from the worldly influences, but we cannot separate ourselves from the weaknesses of the flesh. We have them with us all the time. So we want to conduct this great warfare so it will successfully combat this enemy that is within us -- the flesh.

How shall we do this? That is the important thing. We all know we have it; it is a peculiar weakness, we all know it is constantly causing us to fall; but now, how shall we overcome it? Dear friends, we suggest to you that the body is subject to the will. It suggests to my arm, rise, and it rises; I say go to my limbs, and they move. It is the will-power that energizes, governs, the entire body. This is the thought the Apostle expresses, when he tells us that in former times, we have yielded our members servants of unrighteousness, but now that we have consecrated ourselves to the Lord and have accepted His will, that this new mind must control. These members who were once servants of sin must now be used as servants of righteousness. So, dear friends, we want then to cultivate this new mind.

But it is not a conflict in reality against the new mind -- the double minded man, the one who has the mind of the flesh and the mind of the spirit in the same being, is a double minded man; he is unstable in all his ways; he is not promised that God will give him anything. The Apostle James says, let not that one think he will receive anything from the Lord. From God's standpoint, those who have consecrated have died to their former condition, their fleshly wills have been buried, and there has been an actual transaction from God's standpoint; and while that is true, we realize that it is but a reckoned condition, and we realize that the flesh is struggling to manifest itself, its claims are being constantly pressed upon us, and there are efforts to resuscitate this dead will, which we have gladly buried, as it were. What we want to do, then, is to get this new mind in such an active condition that it will entirely control this body, so that even the motions of sin which are in our body will be changed to motions toward righteousness. How can we do this? The way to encourage the growth of the new mind is to feed it, just as we would have our bodies

grow by feeding them. Well, how shall we feed our new minds? Why, says the Apostle, if then we be risen with Christ, seek those things which are above. Set your affections on things above, not on things on the earth. We do not understand, dear friends, that we can set our love voluntarily from one thing to another, just as we would move a chair about a room. The word "affections" means, in the real sense, and in the original, mind; it is the same word in Romans 8:5 which is translated "mind" -- they that are after the flesh do mind, or think on, the things of the flesh, and they that are after the spirit, do mind, or think on, the things of the spirit. The thought then is, if we be risen with Christ, if we are of that class which have consecrated themselves, and have experienced this reckoned death and resurrection again to the newness of life, then as new creatures let us set our minds on things above, and not on earthly things. If, dear friends, we feed our minds on earthly, sensual things, if we read the novels of the day, if we read the various things that come up in the newspapers of the day, what are we doing? Why we are, to that extent, feeding the flesh, resuscitating to that extent the dead will. And so it is, my dear brethren, when we let our minds dwell on heavenly things, to that extent, we strengthen this new will until it becomes more and more strong, so that it can thoroughly control this body. The Apostle tells us that the spirit will so energize our bodies that they will become servants of righteousness. Is not that the experience of everyone of you? Why is it that you are here today? Can you not look back, some of you, in times past, when you would rather have been at a different place? It is because this new mind has taken possession of you, the new spirit is governing you, and it is causing these members which were once the servants of sin to become the servants of righteousness. Some of our dear friends have given up their former occupations and have gone into the colporteur work; their tongues are employed in speaking the good things of the Lord, in telling the glad message, and interesting others in this grand salvation. But they can look back, perhaps, to the time when their tongues were employed in other things, in worldly things, not sensual things, and so find day by day, as we overcome more and more that we are compelling the members of our bodies to become, perhaps unwillingly, the servants of righteousness.

Why, dear friends, in my own experience, if I were to consult my fleshly desires, I would not have been here. I know other things that would have appealed to me in the matter of worldly considerations more than being here with the Lord's people. But there is nothing dearer to my heart than the Lord's people, and it is simply because this new mind has to a considerable extent so controlled my being that I rejoice in the privilege of being here, and my members which were formerly servants of sin are being energized more and more, and becoming the servants of righteousness. So you see, the sum of the whole matter is overcoming the flesh, and that is the foundation of overcoming the Adversary, and the world as well. The secret in overcoming the flesh lies in encouraging the growth, the development, of this new mind so that it controls the body, instead of allowing it to be controlled by fleshly desires, or resuscitating the old mind which was reckoned dead.

We perceive further that this is in perfect harmony with all of the Lord's words on that point. As a man thinketh in his heart, so is he. It makes a great deal of difference how we think. This is a principle which is well recognized among the worldly; it is a principle that is the underlying thought of all the systems of education -- cultivating the mind along certain lines, along certain channels, develops it. The Lord is simply using a natural law in the development of His new creatures. So our development as new creatures and our efforts at overcoming will be successful

to the extent of our thinking, and allowing our minds and our thoughts to move, along the lines of heavenly things. The Prophet says, let the words of my mouth and the meditations of my heart be acceptable unto thee. Let us ask ourselves tonight, is the meditation of our hearts acceptable to the Lord? Have we been meditating on heavenly things? Have we been meditating on God's plan of salvation? Has that filled our hearts and minds to such an extent that we can realize there has been no possibility for other things to crowd it out? You are well aware it is a natural law that we cannot meditate on two things at once, and so in proportion as our new minds are being filled more and more with heavenly thoughts, to that extent we are crowding out and starving the flesh.

The Apostle Paul also, in the 7th chapter of Romans, tells us another line of troubles we have with the flesh. He tells us of certain motions of sin in our bodies. I understand that to refer to certain mechanical motions, as it were. That is to say, perhaps in our experiences when some one said or did something displeasing some of us, who were very ready with our tongues, apparently we did not have to think what we had to say, but almost instantly we would have some sharp retort to give them -- as good as they sent. That is the result of our fallen condition, the result of this mechanical tendency toward sin that is in our bodies. What we want to do then as new creatures in Christ, is to allow and encourage this new mind, to exercise and to control our being, and to studiously follow the proper course, so that our mechanical tendencies shall be towards righteousness; and instead of endeavoring to injure those who speak evil of us or do something against us, that our first efforts, without taking time to think of it, would be towards doing them some good. This is a difficult thing to do, some might say, and indeed it requires a great deal of study, a great deal of care.

Our brother used the illustration of writing, last night. I want to call your attention to the same illustration again. When I went to school I remember how laboriously I endeavored to form the various letters of the alphabet. Take, for instance, the letter A; I studied the copper plate that was before me, and then made an attempt to copy it. The teacher encouraged me. There was some similarity between that which I made and the copper-plate, although it requires a great deal of charity to express it in that way; but when now I attempt to write the letter A, I do not have to stop and study just what form it will take; almost mechanically, as it were, I strike off the letter A. That is the way it is with you all. We adopt these principles of righteousness and put them into daily use, and we might say hourly practice them, and they finally become almost mechanical operations, so we do not have to stop and think what would be the proper thing to do.

But when I write the letter A today, it does not look like that copper-plate yet. So it may be we never will be able to imitate the perfect copy that is before us, but the thought is that we want to get ourselves, as new creatures, in control of the situation; we want our new minds to control our bodies and control these motions of sin, so that we can act as it were mechanically towards righteousness. This will indeed be an evidence of overcoming.

We must not think, however, of simply overcoming sin. Oh, no, it does not stop there. As human beings simply, if we were perfect, which we are not, we would rebel against the life of sacrifice. Our Lord was perfect and He continually had to say, "Not my will, but thine, be done." It was a continual battle with Him, and so, even if we were perfect, it would be a battle with us to overcome this rebellion of our humanity against the life of sacrifice we have engaged in. But we must overcome. The promises of God's Word are not to those who make the attempt to

overcome, but they are to those who overcome. Let us understand, then, that our overcoming goes farther than the weaknesses of the flesh in the way of sin. We may successfully overcome in that direction, but we must overcome the tendency of our flesh to revolt or rebel at the idea of a life of sacrifice. You remember the Apostle Paul tells us that if we then be risen with Christ, we should seek those things which are above, where Christ sitteth at the right hand of God. Set your affections on things above and not on this of the earth. This is the thought we would endeavor to impress on your minds tonight, that we must set our thoughts and minds on things above, and cultivate an affection for heavenly things. We must appreciate these great promises that are made to us to such an extent that we can say with Paul "I count all things but loss and dross for the excellency of the knowledge of Christ Jesus, my Lord." But not only that, it is an easy thing sometimes to count them but loss and dross, but when the trying experiences of the sacrificing time, the separation, comes, how is it then? Can we say then, with Paul, "Yea and doubtless I have suffered the loss of all things." Let us keep our wills in such thorough subjection that we will gladly suffer all things to the intent that we may finally be overcomers.

The Apostle tells us concerning the transformation of our minds, "Be ye then transformed." What does he mean by that? Why, dear friends, you remember we learned at school that the form of the earth was a sort of a ball. I have a card in my pocket, and let us suppose that our natural condition was something after the form of this card; that we are thoroughly conformed to this earth, that all of our aspirations and desires, everything, are in entire conformity to the earth. Let us suppose that one end of this card would represent our ambitions, and the other end our affections. We have them both pointing down toward the earth, thus (; we wanted all we could get of earthly things; we wanted to place our loves, and did place them on earthly things. The Apostle speaks of this kind of love, or of some parts of it at least, as inordinate affection; we had all our affections in perfect conformity to the world; but when this great transaction took place of being reckonedly risen with our Lord, and having our affections placed on heavenly things, the Apostle says then, "Be ye transformed." What does he mean? He means an entire reversal of our former conditions, so that now we turn the ends of the card up, thus (, as representing our present condition. We will say one end still represents our affections and one end our ambitions, but now we find that our affections are heavenward, they are being placed on heavenly things; we find our ambition is to be an overcomer, approved of our Lord, that we may be a joint-heir in the kingdom; we find that all we have is bending upward. That, dear friends, very fitly represents our present condition. But suppose we are resting just as that card is, on the table, thus (. We find that a little part of it is touching what we will call the earth. What shall we say about that? What does the Apostle say? "Mortify, therefore, your members that are on the earth." What does he mean? It means not only to cut loose from sinful conditions, and this tendency towards sin; it means nothing less than an entire separation from earth and from earthly things. This, dear friends, is overcoming.

So we say then, in closing our subject tonight that, first of all, it is necessary for us to familiarize ourselves with the instructions of God's Word as to the peculiar tactics of the Adversary, so that we may be enabled to know in which direction the attack will come. The Apostle tells us the attacks of Satan and the fallen angels under his control are specially against our faith, so, in order to overcome along that line, we must strengthen our faith. We need to fortify ourselves. We need to put on the whole armor of God in order that we may be enabled to withstand the fiery darts of the Adversary; we need to have the shield of faith. We see that the world also, which is under the

control of Satan, is arrayed against us as new creatures, so, in order to overcome, we need faith. We need faith in order to overcome the world; we want to separate ourselves from worldly influences; but the greatest enemy of all we have observed is that one we have constantly with us, the fallen flesh, which is not only as prone to sin as the sparks are to fly upward, but in addition to that, it revolts against this idea of a life of sacrifice, and we have to completely bring it into subjection, and that can only be done through the influence of the new mind in controlling the body, in controlling this being which is so prone to sin; and in order to have the new mind in thorough mastery of the situation, it is necessary that we feed it by permitting it to dwell on heavenly things, by letting the meditations of our hearts be acceptable to God, by studying God's Word and plan, by associating with those of "Like precious faith," and by talking and thinking about the things of the kingdom.

We do not understand that we are to constantly talk of the kingdom, or to constantly think of the kingdom. We are all, no doubt, engaged in some secular occupation, and sometimes we place our entire attention on the work in hand; but remember the words in Psalm 116, "Return unto thy rest, O my soul, for the Lord hath dealt bountifully with thee." It means that when these things are lifted from us, when it is possible for us to lift our mind and attention from our secular occupation, like the needle of the magnet it will instantly fall to this thought which is so precious to our minds, which brings rest and peace, and comfort, to our souls: "Return unto thy rest, O my soul, for the Lord hath dealt bountifully with thee."

So we want to overcome; we must overcome. Like the soldier in the warfares of this world, we must understand that a great deal of time is necessary in learning the discipline, learning to obey orders. It is not the loyal soldier that questions the orders of his captain. We have settled the entire matter. If we have not settled it, we had better settle it this very minute as to the righteousness of the cause we have espoused, so that when God's will is expressed in a certain direction we will not stop to question the righteousness of the cause, the wisdom of His command, but will be willing, like the soldier of the world is, to go forward into battle. It is necessary that we become thoroughly acquainted with God's Word and with His instructions to us, that we have that hearing ear the Word of God speaks so much about that we might listen for the words of the Captain, and be willing to obey His commands -- not to count on our ourselves in this battle, but to realize, as the Apostle says, that He who is for us is more than all they that can be against us.

So, if we do this, we have the assurance that we will at last be overcomers, that the victory will be ours, through our Lord Jesus Christ; that we will be more than conquerors, and this is the precious promise of God's Word that pertains to the overcoming class -- "To him that overcometh will I grant to sit with Me in My throne, even as I overcame and am set down with my Father in His throne." Amen.

## TUESDAY, OCTOBER 1.

9 A.M. -- Praise and Prayer Service, led by Brother Woodworth.

10 A.M. -- Address to Colporteurs and All engaged in the Harvest Work, by Brother Russell.  
"He that reapeth receiveth wages and gathered fruit unto eternal life."

HOW wonderful a thing it is, dear friends, that our heavenly Father should condescend to permit us to be co-laborers with the Lord Jesus Christ in any part of the work. The more we think on the subject, the more wonderful this seems to be. When we remember that before our father Adam was created, there were holy angels of God who were in His favor, and in His likeness, and who never departed into sin at all, that God in His great wisdom and love and generosity has not only provided a Savior for Adam and all of his race, but has also provided that that salvation should be made known to the world through the Church, which is the Bride of Christ, how wonderful a matter it is. Our first thought doubtless would have been, if we had had the management of it, to take these holy angels, who are so great and wonderful in their character and brilliancy, and to have in some manner used these in conferring the blessings of the knowledge of God's grace and mercy to humanity. But God's ways are not our ways, we read, and His plan and arrangements are not as ours would have been. We are all witnesses of that, not only as respects our own imaginations, plans and conjectures, but as respects all the conjectures that have been formulated, as are represented in all the creeds of Christendom, and all heathendom. God's plans are different from all of those, and yet so wonderful, and so gracious, and so favorable to us, that we could not have asked for anything so wonderful as He has provided.

First of all then is the work of the Gospel Age. We could do nothing at all with respect to the first part. It was necessary that God should send His Son to become the Redeemer. It was necessary for Christ to have been born, so that He could be related to our race, and be the Man Christ Jesus, and that He could give His life, perfect, holy, harmless and undefiled, a ransom for Adam and all the race.

We could do nothing at all in that part of the work. He therefore does not call on us to have any part or share in it at all. But just as soon as Jesus had paid the ransom price, just as soon as He had ascended upon high, there to appear in the presence of God for us, for all who are trusting Him, and for all who believe in Him and turn away from sin and to God and accept His divine favor -- just that soon did God begin to manifest His favor toward mankind. And the first ones were the twelve who were blessed with the Holy Spirit at Pentecost, and were sent out to carry the good tidings of great joy to all people that had ears to hear -- not to anybody else. God was not speaking to those who had no ears to hear, but as many as have ears to hear, let them hear, and so God began right at Pentecost and has been continuing all the way through this age to select a people for His name, selecting a Bride for His Son, to be with Him in the kingdom, and all this work of manifestation, all of this work of gathering a people for His name, and all the telling of the good tidings, is not committed to angels, but is committed to those who accept the Lord Jesus.

What favor is there in that? We look back to the time of Jesus' birth, and there was no man in the world at that time who was suitable to tell the good tidings and make known that part, and it was better that God should send the company of angels in the plains of Bethlehem to proclaim that, "Unto you is born in the city of David, a Savior, that is, Christ, the Lord." It was necessary that that first proclamation should be made by the angels, because if some man had said it, they would have said, "How does he know? Where did he get the information?" But when God sent this first part of the message through the angels, it seemed necessary to use them to that extent, and they were used.



Then came, as we see, the work of this Gospel Age. All through the age, notwithstanding the imperfections of the earthen vessels, the Lord has been pleased to use human instrumentalities all the way down for the gathering of the Church; and He has honored His Word as presented in the Scriptures, and He has spoken through the mouths of those who were His consecrated children. He has honored His message wherever it has gone, and the blessing of the Lord has thus gone out to all the earth -- not confined to the Jewish nation, or to the English nation, or to the American nation, or to any one nation, but the message has gone to all the families of the earth. Then we look at what has been accomplished during the Gospel Age, and we see the ups and the downs, and we see the failure at the end of the first century; we see the Church going into the wilderness condition, and we see the Scriptures telling us that notwithstanding the fact that the whole system has become a nominal system merely, and has gotten largely under the influence and control of the Adversary himself -- notwithstanding that, God did not leave Himself without a witness; He had witnesses all the way down; they were not known or recognized to much extent of men, but nevertheless God had true witnesses all the way down through these eighteen hundred and more years.

Now then, dear brothers and sisters, if we were to look at the most important part of God's Plan in respect to the selection of the Church, where would we look? Well, we answer, we would, of course, look back to Pentecost and say that was one of the most important points in God's great plan -- the beginning of the blessing. Surely it was one of the most important points. The Apostles were there, and a great blessing of truth and grace was on all those who followed the Lord and had a measure of the divine plan, which was doubtless enjoyed by some.

Then where else shall we look for special divine favor? We hearken to the Apostle Peter and hear him say that the blessing has come upon us who are living in the ends of the ages. Now there are two ends to the age; there was a beginning end, and a closing end. There was a time at our Lord's first advent, the end of the Jewish age, and at the beginning of the Gospel age, of lapping; and so now, when we come down to our time, we have the closing of the Gospel age and the dawning of the Millennial age. The lapping of the ages have come upon us, and we are living in that time now, dear friends. There are two very important periods during the last two thousand years, and we are fortunate enough to be living in one of them. As a child I used to look back to the days of our Lord, and think with considerable interest of the hymn that says, "Oh, that I could have been living on earth then." You remember the picture it gives when Jesus was here amongst men. I cannot remember the hymn, but you are perhaps familiar with it. I would like to have been here then, that I might see Him and His miracles. But it seems to me that when we come to consider the matter more fully, the blessings in the end of this age are greater than were the blessings in the end of the Jewish age. At very most, our Jewish brethren of that time saw our Lord, the wonderful man, the man Christ Jesus, and they saw the one who was doubtless far beyond all others in His appearance, and they saw the one who spake as never man spake, and they saw the one who performed various miracles, and all that must have been very interesting; and yet we can see that a great many people could have been there present, and hear and take notice of those things, and yet be in the utmost perplexity. They did not know whether this was Jesus the Messiah, or not. You remember the Bible tells us many of the people said, "Do our rulers indeed know that this is Jesus, the very Christ?" And they were perplexed. The rulers said, "No, no, this man is talking about a kingdom, and we are expecting a kingdom, it is true; we have been expecting it for all these centuries, but this man has no army, and he has no financial backing, and the Roman government would not recognize Him, and we Jews ourselves would not recognize Him. He is a kind of a womanish man, talking beautifully, kindly, gently; He is not swearing any, and getting angry, and rushing around as though He would rip the whole world to pieces if they were not likely to fall into line with Him. We need a man of that kind. That is the kind of a man Israel had hoped would establish a kingdom and bring the other nations into subjection. Haven't we been looking and praying for centuries for the time to come when Messiah would come and rule the whole world, and do you suppose a man like this, who goes around and saying, "Blessed are the

meek" and "Blessed are the merciful," would make a good general or ruler to bring the kingdom to Israel? "How foolish! Your poor common people don't know anything about this matter. Leave the matter to us; we are scribes and pharisees; trust us; we have a grain of sense and know what we are talking about. Pay no attention to that man, and His disciples. I never saw such stupid people, thinking of Him as the Messiah." Now, if I had been there, my dear brothers and sisters, I am sure my faith would have been very weak, and I should have said, "It don't look much like it, does it?" I am really glad that my lot fell in this time for more reasons than one. I believe that for my cast of mind -- now, we are not all the same -- it is a great deal easier for me to exercise faith in the presence of the Lord at this time than it would have been in the days of Jesus in the flesh. I am naturally of a disposition to reason things out from facts, and possibilities and I would have had a terribly hard time to become one of the twelve apostles, or to have gone around with our Lord, without any apparent manifestation of kingly authority then. I would have asked Him a whole lot of questions, at least. Perhaps He would have told me, but I would have asked a whole lot of questions. It would have been a question meeting for a good while with me. How are you going to do it? How is it going to come? How can it ever be accomplished? Explain the matter. And perhaps the Lord would have been gracious to me and said, "Well, he has that kind of a head, and he cannot help it, and I will condescend to make up for him, for his lack of ability to take things for granted. In other words, I would have made a poor rat to go into a trap; I would have wanted to know how to get out at the other end before I would go into the trap.

Now, we have before us the two ends of the age, and we see that at the time of the end of the Jewish age and the opening of the Gospel age, the Lord said there was a harvest work going on; He said that the fields were white already for harvest, and he that reapeth receiveth wages and gathereth fruit unto eternal life. And after telling them that, He sent out the twelve Apostles, and afterwards also, the seventy and told them to go everywhere and to preach that the Kingdom of God had come nigh unto them; the Kingdom of God is very near. If you are ready for it, God is ready to establish the kingdom now. So an opportunity was given, and what was the result? Well, the nation as a whole, we are told, at the time of their visitation, did not discern; they did not recognize Him; they said, it is foolish and silly to think of this being the Kingdom of God that this man is preaching. You remember the pharisees came to Him on one occasion and said, we will show up this man, and said it in the presence of His disciples, for they wanted the disciples and all the people to hear how they would overthrow any of His arguments. And they said unto Him, When will the Kingdom of God appear? You do not mean to say you have it now; you do not mean to say you are a King now; you do not mean to say your disciples have any power now -- how long have you to wait on your kingdom?

And the poor pharisees were utterly disconcerted when Jesus said, It is not going to appear at all.

How is that?

Why it will be in the midst of you, and you will not perceive it; it will be an invisible kingdom. How much they were astonished!

Well, the fact is, anyway, dear friends, that as a whole they could not receive spiritual things, for they were not for natural men. They were not begotten of the Holy Spirit and the trouble was, they were not in the right attitude of heart to be begotten of the Holy Spirit -- that is, excepting a few. As we are told in Joh 1:11, He came to His own, the nation of Israel, and His own nation received Him not, but as to many as did receive Him, to all of those who were Israelites indeed, in whom there was no guile, to them gave He liberty -- privilege -- to become the Sons of God, to step from the House of Servants over into the House of Sons, from fleshly Israel over into spiritual Israel; to them, gave He liberty to become Sons of God, even all those who believed on His name, and who subsequently were begotten, not of the will of the flesh, but of the will of God. It was that little class, the twelve Apostles, and perhaps many of the

seventy that went out -- we do not know whether all or not, probably not all that were sent out -- but the twelve and many of the others, many of the seventy, altogether about five hundred we are told, were influenced by the preaching of the Word of God. That was all the wheat found up to the time of Jesus' death, and that was called a harvest time. They were sent out to reap. Jesus said, I send you forth to reap that upon which ye bestowed no labor; other men have labored, have done plowing and sowing, and ye are entered into their labors; it is the time to reap now, and not specially the time to sow. So they did this reaping work, gathering the five hundred brethren out of the Jewish nation. And then you remember after Pentecost, they kept up the reaping work, because the harvest lasted from the time of Jesus' baptism for forty years, and they were doing a reaping work all of that time. What was the effect of it? The effect was to gather every Israelite indeed -- not only those Israelites that were living in Jerusalem and Judea and Galilee, but the work extended out, you remember, ultimately to the Gentile nations, where the Israelites had gone to live, and where they were engaged in mercantile pursuits -- Athens, Corinth, and in Rome. The Apostles were sent by the Lord and directed by the Holy Spirit, so they went here, there and everywhere. They first of all went to the synagogues of the Jews, and said it was necessary that the Gospel should be preached first to them. Why? Because it was God's arrangement, that those who had been favored with the blessings of the divine law, and the divine guidance, as the peculiar people of God, should have the full opportunity of having a harvest time, and of having all who were real ripe grains of wheat gathered into the garner of the Gospel age, and so that work was fully accomplished. My supposition is, and I think you will all agree with me it is Scriptural, that God knew every Israelite at heart, and did not leave a single one, but every honest Jew, every Israelite indeed, in all of that nation during those forty years was found. God knew how to direct the various influences of His work, so that those whom He sent forth as reapers -- the Apostles, and all who became associated with the truth, each one becoming a reaper -- were blessed of the Lord, so that the whole work was accomplished and no grain of wheat was lost. If you remember, the Lord pictures that as the result. Through John the Baptist it was declared that our Lord's work would be to gather the wheat into His garner and to burn up the chaff. When was it gathered into the garner? During these forty years the wheat of the Jewish nation was gathered. And where was the chaff burned? At the end of this forty years the fire of trouble came on the Jewish nation, and all of that chaff was consumed, in the sense that the nation was overthrown -- lost its national existence. The nation died there. There has been no Jewish nation from that day to this. There is no Jewish nation today. There are Jewish people today, just as there are Polish people, although there is no Polish nation today. The Polish nation perished, but you will find people who came from that land, and who speak that tongue. So you will find Jewish people, but there is no Jewish nation. That nation has been overthrown. Everything went down at the end of that forty years.

So that harvest time saw a double work. It first gathered the wheat into the garner of the new dispensation under the spiritual ministration, it gathered the wheat of the Jewish nation, and it also did the cleaning up, or the burning up, of the chaff. So that work was concluded, as far as they are concerned. The work has been going on outside of them altogether -- it has been with the Gentiles.

I remind you all how the Lord cared for the true Israelites there. You remember how Nathaniel was brought to the Lord's notice. Two of the disciples had been well acquainted with Nathaniel. They knew him to be a very fine, honest, honorable Jew, and he knew them to be true, candid men also.

So, after they had found Jesus and had become His disciples, they went and found Nathaniel and said, "Nathaniel, we have found Him of whom Moses and all the Prophets did speak; we have found the Messiah."

"Oh, my friends, my brethren, are you being deceived by that Nazarene?"

"Nathaniel, he is the most wonderful man -- come and see for yourself."

"Oh, my brethren, I am so sorry for you; you have been caught in that snare. I have heard of other good people being caught in that; I am sorry for you."

"Now, Nathaniel, come and see; you can do no less than that as a true Israelite; you cannot refuse to examine the matter. Can you refuse to examine that which commends itself to your brethren with whom you are well acquainted, and whom you know to be honest Israelites? Are you afraid to examine? Do you not know that God has promised the Messiah? Come and see."

Well, Nathaniel concluded that he would have to go to see. But on the way, you remember, he felt the importance of the matter and realized that he might be subject to deception -- he might make a mistake and be at fault. He knew there were false Messiahs being received lately, and he might be deceived, too. There was a large fig tree with its branches coming down towards the ground; under the fig tree he crept and said, "I will have a prayer with God before I go, because it may be a new temptation, a new delusion, and I want the power of God to be with me to help me to know whether my friends here have been deceived, or whether this is the true Messiah." So he went under the fig tree and prayed for wisdom, for knowledge and for aid from the Lord. And then he said, Now I will go. Presently he came, and as he was approaching, our Lord said, pointing to him, "Behold an Israelite indeed, in whom is no guile."

Well now, thought Nathaniel, I hope, I trust, I am an Israelite indeed, and I hope that I have no guile; I hope that is all true; but it does sound to be a good deal as though that man were trying to catch me by saying something pleasant -- in our day, we would say, giving him some sweets. So Nathaniel hesitated a little; that was not going to be sufficient proof to him; so he said, "How do you know anything about me, Sir?"

"When thou wast under the fig tree, I saw thee."

"The answer to my prayer! How could I ask it better?"

The Lord had fixed it so that, being an Israelite indeed, it was very easy indeed for him to find the Master, and get right into confidential touch with Him. I do not suppose that is all the story; it is all that is recorded in the Word -- and a little more than is recorded in the Word indeed, for I have paraphrased it a little, but I suppose the facts are that Jesus told him a good deal more, and that they had quite a heart-to-heart talk about the matter. I suppose there was quite a good deal of conversation there. We can't believe that our Lord in all the three and a half years of His ministry said no more than is recorded of Him in the Gospel. You and I would have talked a hundred times as much in three and a half years. But there is enough here and the best part, and the right part, is recorded, so we are very well satisfied.

Anyway, dear friends, the point is this: that there were a great many Jews there to whom our Lord did not talk or try to make it plain. You remember the disciples were surprised at times when He spoke to them in parables and dark sayings, and used figures of speech, and said, This is the bread that cometh down from heaven. If you eat of my flesh, you shall live always. What does this man mean, when He says to eat my flesh? No wonder these poor men were confused. These are very precious words to us because now we understand them; but to those that heard them, and who had no knowledge of spiritual things, no conception of how Jesus was to be the bread of life for the world, all of these must have been very dark sayings indeed. When the disciples asked of Jesus, Lord why do you tell the people these things in such obtuse and parabolic language, He said, To you it is given to know the mysteries, but to them that are outside, to all the outsiders, these things are in parables and dark sayings, so that they might not understand; it is not for them to understand; if they are outsiders, they are not in the right attitude. If they were in the right attitude they would come here to me; they would be my disciples, and I would make the matter clear and plain to them; but they are not for them now; but they are for you. The Lord might have

blessings for them by and by; but now all the blessings He had were for those who were His -- to those Israelites indeed, in whom there was no guile.

So we carry the parallel from that harvest time down to this harvest time, and we have the sanction of the whole Scriptures in doing this. For instance, we find the Jewish age was a type or pattern for this Gospel age, and that, as God dealt especially with the Jewish nation for 1845 years, so He has dealt with the Gospel Church, Spiritual Israel, for 1845 years. As He has thus dealt with them, and made the one the pattern for the other, we are justified in looking at what was accomplished in the Jewish harvest by the Lord and His Apostles, and we are justified in expecting similar conditions in this harvest, only on a somewhat higher plane, because ours is spiritual Israel and theirs was natural, or fleshly, Israel; ours is the heavenly calling, and theirs was the lower calling; ours is the house of sons, and theirs was the house of servants. Therefore, everything here properly belongs on a higher plane. They were taken out of the Jewish dispensation, from the house of servants, into the Gospel dispensation, on the higher plane, and that was the garner for them; and we are to be gathered from the gospel plane to a still higher plane, the spiritual plane, changed in a moment, in the first resurrection; so our things are all higher than theirs. But these two ages are parallel, and the two harvests are parallel, and just as the Lord in the end of that harvest sent forth His disciples to be the reapers in doing the right work, so likewise in this harvest, He is sending forth His people, the spiritual Israelites indeed, in His name, and as His representatives, in doing a harvest work. He is telling us to go everywhere, wherever we find Israelites indeed, and tell them this is the day of their visitation, tell them that now is the presence of the Lord and the harvest of this age, tell them that God is not going to be forever calling the Bride, that the elect will all be called, and that this age will end, and that this is the work in the closing of the harvest time in which the wheat shall be gathered into the garner. And as there the work was successful, blessed of the Lord, and accomplished all that He intended, so it will be here; it will accomplish all that God purposed. If we look back there we will find that the people of that time did not suppose there was any great success; they did not suppose the Gospel Church was making any headway. They would have looked at this fact that there were five hundred people out of the millions of the Jewish nation, and would have said that it is a very trivial thing. What is that, anyway, finding five hundred people in three and a half years ministry, after all of these miracles? Or if it was five thousand, how small was the work compared with the whole Jewish nation!

And what do people today say? Well, you people are very small. Yes, we say, we are very small. You are very insignificant. Yes, that is all very true. Why you think you are going to tear down our churches, and you are not going to do it. Not at all; we do not think we are going to tear down the churches, my brethren. I remember a gentleman who called on me; he was not a minister, but had been educated for the ministry; he was a printer, and had been doing some work for us, and incidentally talking about the matter, he said, "Mr. Russell, how does it come that you seem to be trying so hard to tear down all our churches?"

"Why, my brother," you have misunderstood the matter. I am not trying to tear down the churches."

"You are not?"

"No."

"What does it mean that we are printing so many of these tracts and booklets, etc., and what our shop is doing is very little compared to what other shops are printing for you; you are printing thousands and millions of tracts that are going all over the world. What does it mean if you are not trying to pull down the churches?"

"Why, this is what it means: In the first place, we do not want to pull down the churches; we want the churches to stay; we want them to keep a tight band about all the tares, and hold them in there. If all of

the tares got out, they would get in with us; we don't want any of them; what we are looking for, my brother, is to get the wheat, so we look wherever we can and hunt for all the heads of wheat, and try to get them. You will never miss them, they are few; you will never miss them out of any of the bundles; so don't you be afraid, my dear brother; the distributing of a lot of tracts does not mean we think that we are going to get a whole lot of people. We know that not very many wise, or learned, and not many all together, are going to get all of the wheat, and you will not have a single grain left, but you won't miss them very much, because they are in the minority now, and you think them very odd, peculiar people, and you had better be rid of them maybe, and we just want those."

He said, "If that is all you are after, why do you make such a stir, and spread the thing around so?"

I said, "I will tell you: that is the question, we do not know who the wheat are, and the only way for us to do is to take in everything, everywhere, so that we will be sure to reach the wheat in some way. If we only knew the wheat, we would not bother one of the others at all; we would take the truth right to the wheat; but we do not know the wheat; the Lord has kept that secret from us. The Lord knoweth the wheat, and He is going to guide the matter."

Now, dear brethren, why does not the Lord tell us where the wheat is? Why does He not make the thing simple and easy, so that we can come, for instance, to Norfolk and say a word to a dozen, or two dozen, or whatever number of genuine wheat there may be, or a hundred or two hundred -- I could not say how many; the Lord knows, I do not. But why don't the Lord fix it so that we can just get at the wheat and fix it up with them? And so in Allegheny, and New York, and Philadelphia, and all over the country. Why don't He fix it up that way? Well, I think the answer to that question is the answer to our text today. God could have gotten all the Israelites indeed in the end of the Jewish age very much easier than in the way in which He did get them, very much easier than to have Jesus and the Apostles go around everywhere preaching the Gospel; He could have done it very much easier than that if He had so chosen; He knew the hearts of these people; He could have picked them out and sent some word. Why did He not do it? To my understanding, there was a great blessing to be given to the reapers, and the Lord is going to give us a chance to do some reaping work now. You remember the illustration of the Emperor moth. A doctor was very fond of butterflies, and was making a large collection; he heard of a very famous kind of a butterfly he did not have in his collection, and a friend presented him with the Emperor moth in its cocoon, and so he put it up in his library and said, I will watch the development of that butterfly with interest. And gradually it began to show evidences of life, and made struggles and worked to get out of the cocoon; and as day after day he would glance up and see the little animal working and fighting its way out, he said, It is too bad, I could let it out easier than that; it should not have to work like that, so he snipped it with his scissors; and the thing got out finally, but he let it out too soon, and as a result of not having enough work, it could never fly; it was too weak. It had not had muscular effort enough in getting out.

So we think that is the reason the Lord allows us now to do the reaping work; it is necessary in His plan and it is necessary for our development; that we should not only have the opportunity of doing something in the Lord's service, but see the reason for it, for if we could see no reason for it, or if we knew our labor in the Lord would be in vain, it would not be very easy to do. Suppose now, for instance, in a certain town, there was not a single grain of wheat, and you knew it. Would you say, Well I know there is no wheat here, but I need the exercise and I will go over the town and spread tracts all around even though I know there is no one here that will be interested in the truth. Do you suppose it would be possible for you to do that, to spend time, labor and car-fare? You would not want to beat the air, so you see God kindly veils our eyes, and does not tell us whether there are any grains of wheat there or not. It is going to do us good to go around and do the reaping and serve the cause, so He veils our eyes, and does not tell us where the wheat is, but gives us the assurance that He knows where it is, and that He will not let a grain of wheat be lost; but He will make sure that every grain is reached in some way, and it is our

opportunity if we want to be reapers, and if we want to receive some of the wages, to get to work, and according to the energy and zeal we display, we will be manifesting our love for the Lord, for the Brethren, and for the truth. So then, these opportunities of the harvest time are most wonderful.

I do not know how to account for the various features of the harvest work that we have, except to say that the Lord apparently guided our judgment in respect to the matter and gradually opened them up before us, and they seemingly were made necessary by certain things; as, for instance, in the matter of the Pilgrim work. We found that there were little companies of the Lord's people here and there that needed to have a little encouragement, a little bit of help; they had a certain amount of ability and could carry on a certain kind of meetings very well among themselves, but if they would have some additional encouragement, someone to come around and visit them, to help them, and to advise and counsel with them, some who probably had more experience in the truth, or more experience in respect to the holding of meetings, this would be a great advantage. So we started by having one or two go around and as we found the work was increasing and needed more, and as the Lord seemed to provide more, we arranged for others to go around, and they kept going and are going all over this country, and to some extent over other countries, though not so much anywhere else as here. But we see how that part of the harvest work was brought in; there was a necessity for it. There were little classes growing up in their various places needing help, and there was a way to meet this very exigency. The Lord seems to direct the path, and it is grand. We now see that this Pilgrim manner of serving the meat to the household of faith is one of the wisest and best -- far wiser than we knew at the time. It is carrying some fresh thought and ability to every class of any size all over the country, to do them all the good possible, and that without hindering the balance. It is far better than having a paid preacher established in every city; it accomplishes more good. A little class must help itself, and must edify one another, and that is what God intended. God's intention never was, in connection with the Church, as the early Church's example would show, that the Church would simply meet together to have somebody preach to them; the Church was to meet together to edify itself, to build one another up. There might have been, and probably was in every congregation of the early Church, a leader, and may be several leaders, who would take turns; but it was not the Lord's plan that one man should do all the teaching and the others do all the hearing, but that all should co-operate in the service, each according to his ability and according to what seemed to be the Lord's providence in the matter.

So these little congregations, instead of being encouraged to give up and sit down and hear something, were all encouraged to co-operate and be Bereans, searching the Scriptures, and pointing out their fulfillment, one to another. It is the very best way. I do not know of any other way that would be as good for the edifying and for the bringing out of the talent, small and great, wherever it may be, either in asking questions, or answering them, or in helping them in any manner; and as a consequence those all over the country who never would have known they had any ability, and whom others would not have known or found to have ability have, under the Lord's blessing, and as they come to a clearer knowledge of the truth, considerable ability in pointing out to each other the precious things of the Lord's Word.

Then again, in the matter of the colporteur work; The colporteur work when it was first started was not what we had planned at all. We were not smart enough; we did not know enough. We tried to introduce the literature in the usual way by advertising in the usual manner in the newspapers, and by getting the books into the book stores, so the people would see them, and so they would be put out through some wholesale house and be taken to the retail places in the country and the people have a chance to come at them in that way. And the Lord permitted the Devil to pen that way up thoroughly -- so thoroughly that we could not get any out. I have told some of you, and will tell others now whom I did not address on this subject before, how that the principle book concern handling religious books in the United States tried the Dawns. They first of all said, Yes, send us one hundred copies of the first volume. So we sent the hundred copies, and in about ten days or two weeks, the books came back. We wondered, and inquired how it happened, and got the information, finally, that the gentleman who was at the head of that establishment was very intimately acquainted with some of the premillennial people, Mr. Moody and

Major Whittle. He put the Millennial Dawns on the book shelves among other religious books, and in the department where the premillennial literature was kept. You have probably heard of Major Whittle as an evangelist, who used to be associated for some time in holding meetings and in evangelistic work with Mr. Bliss. He came in and looked over the books in this department. They were arranged in rows, and he saw Millennial Dawn.

"Here, look here, what have you got Millennial Dawn on here for?"

"Well, now look here, Whittle, I am not so narrow as all of that. If anybody wants Millennial Dawn or any other book, let them have it. If they want your books let them have them. I am not so narrow and hide-bound as that; people have a right to get what they want."

"Revell, if Millennial Dawn stays on your counter, all of my books, and all of the books of my friends, will come off."

"Well now, Whittle, if you are going to talk that way, they will have to come off." So he ordered them taken off and sent back to us.

That settles it, you see, in short order. We tried advertising Millennial Dawn in some of the religious newspapers. We even took the method of having the address away from Allegheny, so that they would not even smell that way; they were advertised as Scripture Studies, and an address of another city given, but it was not long before they were found to be Millennial Dawn. Then immediately the contracts were cancelled. The contracts were to run for months, but they were cancelled at once, they paid back the balance of the money, and said they would not have that published in their paper at all. So neither the Methodists nor Baptists or anyone else would have Millennial Dawn in their paper or on their bookshelves, and we could not do anything with them that way.

Now, why did the Lord allow Satan to block all of these ways? It looked as though the Lord was allowing Satan to hinder the work, and perhaps Satan thought he had put in a real good stroke, -- but he did not know his business. Just the same as when he thought he had done a real smart thing when he got our Lord crucified, it did not work his way. I suppose he instigated Judas; in fact that is what we are told, that Satan entered into Judas, and that was part of the prompting which led him to sell the Master, and I suppose Satan helped those who were trying to accuse Him, and those who finally crucified Him; I have no doubt he was engineering that whole thing; but he engineered it God's way, and so these, when they were hindering Millennial Dawn from being advertised and being put on the counters, were co-operating with God, but did not know it, for when we found they could not be advertised that way, then the next thing was to start out and try to sell them.

Well, at first we were trying to sell them at the regular prices at which other people sold such books. They were costing nearly fifty cents in paper binding, the way we were publishing them, in small quantities, and we were selling them for one dollar in cloth binding, the usual price for such books; and then we thought, if these were published in larger quantities could we not get them out cheaper? So we got them out cheaper, you remember, so that we could sell the paper-bound ones for twenty-five cents, and the cloth bound ones for fifty cents. So, for a while we sold hardly any but the paper bound copies. They were entered in the Post Office as second class matter, with the privilege of mailing at a cent a pound, and you remember we finally got it down to where we could send ten volumes by mail delivered to any address in the United States for one dollar. We thought we had done something wonderful, and so we had, and a whole lot of books went out that way; and then what do you think? It looked as though Satan had gotten the upper hand on us; he had tried it several times before. They got a man in the Post Office department who would not obey the law. As long as they held to the law, we always got the better of it. This man said, I am going to make the law myself. Congress did not make the law right and I will



construe it myself so that you shall not send that through the mail, nor any other thing of that kind, at that rate. He did not merely rule this against Millennial Dawn. The gentleman was fair enough; it was a general rule of the department against all magazines of that character going through the mails at that rate, -- the pound rate, as they called it. What was the result? We could not send out the Dawns ten for a dollar, for the postage alone amounted to about ninety cents on the ten. What did we do then? Well, temporarily, the Devil got them stopped pretty well. We had been and we were sending them to colporteurs in every direction at these rates, as well as to other readers of the Tower, ten cents pre-paid; and the colporteurs were selling them at a quarter; but the Devil stopped that. Of course, I do not want to accuse the Devil of anything improperly. But we thought, well, what will we do now? We thought, we will see if we can do any better by getting a cloth bound book at a very low price. So we hunted around and applied for bids on large quantities, and finally got it so that we could say to the colporteurs or any of the friends, we can send these to you so you can sell them at thirty-five cents, and if you get them by freight they will cost you eighteen cents, and you have about one-half of what you get for them for your expenses on which to live. That is a very remarkable thing, that books could be gotten out at that price. I do not know of any other similar size books that are selling at that price. We sell all the translations, the English, the French, the German, the Greek, the Norwegian and the Swedish, etc., at one price, and the foreign editions that are small necessarily cost a good deal more. The English books we sell to the colporteurs at sixteen cents cost sixteen, sometimes a fraction over, according to varying circumstances, and the foreign ones, some cost twenty, some twenty-five, and some thirty cents a piece, so that last year, the Society lost nearly four thousand dollars just on the price of the books alone. I merely mention this so that you will get the situation before your minds -- not that we are making any complaint about it; it is all right. We are very pleased to have it that way. We think that is the way the Lord would have it to be. We want all the poor foreigners who have gotten away from superstition and ignorance to have an opportunity to get the truth at no more cost to them than to anybody else. So as the government carries some letters to California for two cents, and it certainly costs more than that to deliver the letter, and they charge the same to carry a letter across the river from Allegheny to Pittsburgh, just so we make a common rate on all Dawns, as low as possible, so that the colporteurs can have consideration, and so that they may be able to sell them at such a small price that they can have enough left to defray their expenses if they live economically.

Now then, dear friends, under that arrangement, instead of paper books going out, it is cloth books that are going out. You say, is there any difference? Don't they all read alike? They all read alike, but there is a great deal of difference in this way: when a paper-bound book has been laying around for about a week, and several people have handled it with greasy fingers, and the cover shows marks of fly-specks and grease-spots, and becomes a little torn and wrinkled, people throw it in the closet or some place else, and that is the last of it; so we find it is a great deal better to have cloth-bound books, because they lay on the center-table, and friends will come in and say, What is that book? And they will find them years afterwards, because they are in a more substantial form.

So that which seemed to be an adverse ruling of the Post Office department, and that which we fought hard and tried to get it changed and could not, turned out all right. All things are working together for good to us, and always have been. It just takes a little time to see it.

Now then, as a result today, what do we find? We find that the first volume has passed the two million mark. And as far as I know, no other book except the Bible has reached such a sale as that; and it is going on and increasing. We do not have any printing establishment of our own. We could not do the work as cheaply as we get it done, because I suppose if we were trying to do it ourselves, we would have to have a plant for that alone, whereas these other people have a plant going and working on other things, and some of them smaller jobs out of which they are making more profit. They have to keep things going anyway, and they just charge a certain profit on what they do our work for, and it comes to us cheaper than if we did it ourselves. Then we do not have to keep the money invested. We can keep turning the

money into tracts, and keep sending it out. So the money goes a great deal farther, and that is what surprises some people; they say, There must be a mint of money behind this work. We never heard of so many tracts going out. But our money is not all eaten up by salaried officers, large buildings, interest on mortgages, etc., that are very heavy. The money is going out in the work, and is done economically and as wisely as we know how.

Now as to the colporteur work, I do not know just what the report for this year will show, but this year is already ahead of last year, and we have time in which more will go out. But in connection with this colporteur work, we believe it is not merely the plan to let the books go out. We could have done that by newspaper advertisements. Some newspaper might have given a great write-up, and had the other papers copy it, and the people would have gone into the book-stores and said, Have you any of those books, I want one? There might have been a great rush for them, and they might have gone out over the country very quickly. But that was not the Lord's way; He wanted to give you and me an opportunity of working. He said, "There is the harvest work, go in, he that reapeth receiveth wages. I want to give some of the reapers a chance." If the newspaper people had done it all, where would the reapers have come in? Where would they get the wages? "He that reapeth receiveth wages and gathereth fruit." Is it not a great blessing and privilege that we can have in this harvest work? It is not merely the colporteurs who are having a blessing. There are others that are having a blessing, as I think, for instance, of one; I was talking to him not a great while ago, and mentioned to him about one of his family being in the colporteurs' work, and said, How happy you must be, not being able to get into the work yourself and have a personal share in it, that you have at least a number of your family engaged in it? He said, O yes, how much I appreciate that! So, you see, we all are more or less interested, and are drawn together by the very privileges we are enjoying. One may be doing more of actual work, and the other may be sustaining, advising, helping, encouraging, or speaking a kind word, or perhaps taking duties and responsibilities that would hinder this one from going into the work, and perhaps another one says, now you can be spared because I can do some of these things for you. So, each one is helping the other.

About how many colporteurs are there, dear friends? Leaving out Great Britain, Australia, and other places, there are about five hundred in the United States and Canada. Now that is five hundred that are having a great blessing, and many other hundreds that through them have their zeal and love intensified, and are kept warm by their efforts, and that is not all. Besides the colporteurs, there are the Sharpshooters. By sharpshooters, we mean those who simply sell to their friends, give away some, and sell some. We call them sharpshooters, because they are not going from house to house, trying to put them into every home. The sharpshooters are doing a whole lot, and are getting a whole lot of blessings.

And then, when we could not have the paper-bound volumes of the Dawns to supply to the friends at ten cents a volume, the Lord let us think of another way of doing it. The Watch Tower is a regularly entered publication of the second class, under the Postal laws. There is no hindrance to the number of pages in it, and so we issued the first volume of Dawn as one number of the Watch Tower in magazine form at five cents per copy, postpaid. If the Devil thought by stopping the ten for a dollar he was going to do us up on getting cheap books into the hands of the people, he was mistaken, because it merely led to a five cent edition, which is only half as much. Now you do not know how many of those are distributed. I know a brother who in the state in which he lives has circulated at least three thousand of those himself, and paid for them all out of his own money. He has sent them all around, all through his own county and in many parts of his State. He is only an example; there are others thinking how they can do somebody good. All the rest of the world is thinking how they can get something, but those who get the truth are thinking how they can do some good, or give somebody something. It changes our hearts and lives. People can hardly believe it of you, that you are trying to do something for them that would cost you something; they cannot understand that. Well, we are willing to be peculiar in that way.

And then, the volunteer work: You see this harvest work advances in all these different features. At first,

we used to do more as others do in the tract work, publish tracts, and people who wanted them might pay so much for them. Then we thought there was a better way than that -- to let anybody who wished pay for them, let him make contribution to the tract fund if he wanted to voluntarily; we shall not ask for anything, but let him make it if he wants to, and thus we can distribute tracts, and let the friends have free all the tracts they can use. Very frequently the ones who can distribute tracts are the very ones who could not pay, and very frequently the ones that can pay are the ones that might find it impossible to distribute tracts; quite a good many make donations to the tract fund, and they get the tracts and do the distributing also; but anyway, we concluded it would be the Lord's will that the tracts be supplied free, and let them go out by the thousands and tens of thousands and by the hundreds of thousands and by the millions, and I might say, by the tens of millions.

Well now, as a result, dear friends, the tract distribution in which you are engaged, and in which I am engaged, and in which many of the Lords' people all over the country are engaged, we call the volunteer work, because it is not urged on any one, but is a voluntary act, something in which anybody can engage. Now the Lord has fixed it so that nobody can say, Lord there was nothing I could do; for they might have said, Well, we cannot all be Pilgrims, and that is so; and some one might say, I cannot be a colporteur, because I have a family, or other responsibilities; there is nothing that I can do. But no, the Lord took away all that. We did not think of it this way at first; we merely thought of making the tracts free, and letting everybody have them to distribute that wanted them, but you see the Lord was making a way by which every mouth would be stopped, so that nobody could come later and say, Lord, there was not a bit of reaping work that I could do; I was so anxious to do some reaping and I could not find any to do. The Lord says, no that is not right, I gave you something to do. There was a lot of volunteer work to do, and you knew you could get the tracts for nothing, no matter whether you paid for them or not; the freight was paid on them, and they were set down at your town and you only had to go there and pick them up and distribute them.

Well, the matter has been growing and it has finally come to be called the Volunteer work, and we encourage the friends all over the country, and in Europe and Australia, and all around, in every little class, wherever they may be, in country towns or in cities, to form a Volunteer Corps of those who would like to engage in the work, and if it is a city or town of some size, to divide up the classes or towns, so that each would attend to such a part of the territory as he or she could work, and do it thoroughly. And we encourage them to appoint a captain in each city, -- one who would take general charge and lay out the work, and say, this quarter for so and so, and that quarter for so and so, and divide it up. Then have lieutenants, say in the northwest portion of the city there would be a squad for distribution with one to be a kind of lieutenant, or one to have supervision of that quarter, and the others to co-operate with him, and so on. In that way, there have been little armies of tract distributors over the country.

Some might say, I wonder if there are enough of those very common people to distribute tracts; I wonder how you find enough of those common people to distribute tracts. We do not want any common, dirty, superstitious people to distribute tracts. You do not want any of them to distribute tracts. What do you want? You want sons and daughters of God -- God's sons and daughters who want to engage in the harvest work. If God's people do not take pleasure in making known the message, why, then let it stay at home. So, we do not urge anybody, except in this sense, dear brethren, that as we are saying now, there is a great harvest work and the laborers are few in comparison with the possibilities of the hour, and the possibilities of the hour are the most wonderful possibilities, and it is the most wonderful message of the grace of God, the love of God, the justice of God, the Plan of God, that was ever presented to the world, and it is a great honor God has conferred upon us that we should be counted worthy, that He would let us have a share in this work. He could have done without us altogether, but He has done it for our benefit, that we, just by energizing ourselves, might be making character, and as we are making character, we are making ourselves more and more fit for the kingdom of God, for He has determined that none will be in the kingdom who are merely wishy-washy. God tells us He is seeking jewels. He is choosing out the

jewels, and He gives them an opportunity for the development of character, and says they must be overcomers; every one of them must be an overcomer, if he would have a place in the kingdom. So now, dear brethren and sisters, here is an opportunity to become an overcomer. What do we overcome? We are to overcome the world, the flesh and the devil; that is the correct statement, of course; but you cannot overcome the Devil very well; you may resist the Devil, but it will take the Lord to overcome him; and you cannot overcome the world; the world is too mighty for you; you have to simply keep out of the way of the world -- go not into the world's way -- but you have something to do in the way of overcoming your own flesh. There you have your battle-ground -- your pride or whatever it may be. I do not know, I am not judging anybody, I am merely saying it is your battle, and when you come off a conqueror and a more than a conqueror, it will not be because you have routed the Devil and made him flee, and not because you have vanquished the world, but it will be because you have become an overcomer in your own heart and in your own mind. That will be the victory you will gain in your own case, and that is where you will be a conqueror and a more than conqueror, through Him who loved us and bought us with His own precious blood.

Now, we are taking no credit at all for this arrangement; we did not arrange it at all; we are not smart enough to arrange it. We see the things that God has, in His providence, graciously opened up; we see that it is the power of God, and what a wonderful blessing it is bringing to those who are engaging in this volunteer work.

I think of a brother who before the volunteer matter was arranged was a business man in quite a large city, and he has had a good deal of zeal for the truth for a good many years, but since the volunteer matter came out, and since this plan of distribution has been arranged, he used all the powers of his mind more apparently for the service of the truth than he does for his own business, yet his own business has not suffered, apparently. It is not a long while since that the same man sent a contribution to the Watch Tower Bible and Tract Society for one thousand dollars. He said, Put this into the work. He is also spending a lot of time in the volunteer work; he is a prominent merchant in his place. I do not know what he is worth, I never asked, it is none of my business; I am merely telling you what he does. And not only is he active, but he co-operates with all the brethren in his city. It is not necessary to steal opportunities from one another -- there are enough to go all around, so that all can have a share; so we do not want to be greedy and take it all away from others. I am sure that all who live in the city with this brother have abundant opportunity. Then in addition to their own city, they go out to the neighboring towns, on the electric cars, and while a good many of them do not know how the car fare is paid, I happen to know indirectly more than perhaps the others do; but a whole squad will go down to those little towns, writing down there before hand to some of the brethren who may be living there and say, have you been doing any volunteer work? No, we have not. Well, we have been thinking of coming down and helping you, and do the whole town up in one Sunday, or nearly all, so that you can finish the balance. Would you like to have us come down? Yes, we would be pleased to have you come. Some of them cannot be served by the electric cars, so this brother has an automobile that holds five, and he gets that automobile and enough ammunition to distribute in that town, and then on to the next town, and they do a number of towns. You see, it all shows the way the friends are working. There is no people working for anything else like that. You would have to pay them a good salary for anything else. What, for instance, would that man charge to advertise Pe-ru-na? Not much, my friend, go out and advertise your own Pe-ru-na. But when it comes to the gospel, with his whole heart in it and his life consecrated to it, and when he knows he has the best thing under the sun, or over the sun either, he says, I cannot do too much of this. There is that man, not only working with his time and strength, but with his money also to pay for the tracts.

Now, all cannot do that. I am giving that illustration of what you should do -- take your automobiles, etc. Some of you may have three or four automobiles laying aside, but I think very few of you have.

What I am pointing out is, that the truth does not strike people as other things do. It makes a different impression. I do not see the person I am going to mention, and I will speak of what was done in another place. In another quarter of the United States they have a very enterprising class, a very diligent class, and it is a large one, too. There are several very prominent brethren there, and they engage in this volunteer work. One of them was telling me how he first came to be interested in the truth. He said he was an Episcopalian. He said, I might go back of that and say I was born in China: my parents were missionaries, and I was born there, and afterwards sent to this country to have my education finished. I was an Episcopalian, and one day, as I came out of the church, I saw a man handing out tracts, and I said, is that a man handing out tracts and not a boy! A man handing out tracts? Why, I know the man! That is a man having several grocery stores. I know he has three or four at least; I know he has several, and what is he handing out tracts for? I wonder who pays him for that. Nobody, I am sure. There is his carriage and he is distributing tracts at the church door. I never saw anything like that before; I am going to get one of those tracts. He said, I got a tract, and I read it over and said, Well, there are some good things in that tract, but I am not convinced by any means. But there is something behind this, for that man is not doing this, except he is deeply interested; that is more than the average consecration to God and loyalty to his convictions. I am going to see what that book is. So he sent and got the book, and he began to be a reader, and now, he says, I am out with the volunteers every Sunday myself. He is a banker in Washington city.

Not long ago in Washington, one brother said to me, "Now Brother Russell, some of us think there has been a little mistake made this way: you know General Hall, of the United States Army, is now interested in the truth?"

"Yes."

"Well, General Hall we elected Captain of the volunteer work this year."

"Yes."

"And what we find fault with is this: General Hall is pretty well acquainted, and all the privates and lieutenants, as they meet him, are by law obliged to salute him, and General Hall, as Captain of the volunteer work, laid out the territory, and assigned who should go to such and such a place, and very unwisely, we think, chose for himself the very part of the city in which he lives. We think that is not right."

I said, "Now my dear brother, don't you say anything about that. I have been wondering while you were telling me, that if I had been in General Hall's shoes if I would have had as much courage as he had, but I am not sure that I would. General Hall has shown more courage in what you tell me than he ever showed on the battle-field in the Philippine Islands when he was over there. I think it takes a great deal more courage for an officer in the Army to go down where he lives and hand out tracts and put them under the doors, and meet his friends on the way, and salute them and be saluted by them, than it would take to go into a battle. I think there are a good many people who would go into a battle who would not go and do what General Hall did. You see, dear friends, God is using that very means to develop and crystallize character, not only in General Hall and some of those others, but to all classes of people everywhere. Then, it has another good effect. If you have gone around and distributed some tracts that are along the line of consecration to God, it will make you straighten right up yourself. You will say, Look here now, people will be looking at me more than ever; they will say, he is claiming to be religious, and he must be more than ordinarily religious when he distributes those tracts, and he will have to walk very straight. So it does you good. If everybody is looking at you, and you have to walk still straighter, all the better. And then, it helps you to remember that God is looking at you, and that is the best of all.

So, dear friends, this work of reaping is giving some of its wages now. We are getting characters formed, characters on which God is placing a grand blessing; characters He declares He is seeking. He seeketh such to worship Him as worship Him in spirit and in truth, and that means no fear of man; that means full devotion to the Lord; that means a full willingness to give all that we have in His service; when we think of what that means, all that we have, why, dear friends, we feel almost ashamed to see how little it is. How little you have that you could give the Lord, and how little I have that I could give -- a very few years of imperfect talent, and imperfect ability in every way -- but do the best we can, and we are ashamed to offer it to the Lord. We might not be ashamed to offer it to some poor man or woman and say, I have done a little favor for you, and we might feel that we had done something for them and that they were under a measure of obligation, but when we think of God, so high, and so great and wise, and so far above us, and of our own littleness and imperfection, and then to think that we would be permitted to offer ourselves and to spend our lives, and that God would say, Yes, I accept you as ambassadors, you are my representatives in the world; God's kingdom has not been established, but you are representing that kingdom in the midst of a perverse and crooked generation! I think I can never thank God enough for my part, and I think you can never thank Him enough for your part. So let us do all in our power, and remember that God Himself has said, "He that reapeth receiveth wages" -- and then what? "Gathered fruit unto eternal life." What kind of fruit are you gathering? Why, this very experience is making your own heart overflow, and your own character fruitful. You remember how the Apostle Peter says that, if ye do these things ye shall never fail, but they shall make you that you shall not be barren or unfruitful in the knowledge of God. What kinds of fruits shall these be? Why, this very attempt to serve God and to serve His cause will cultivate that for which you are praying. If as Christians you are praying aright, if you are making your chief prayer that you may have more of the Lord's spirit ruling in your hearts and in all the affairs of your lives, then this will be one of the very means of development, whichever part of the harvest work you may be in, and whatever your hands find to do. And we might not all have opportunity of doing many of these things, but at least our hearts are there. But if we have no opportunity to volunteer, or to colporteur, or to do sharpshooting, our hearts at least should be there and we should be in sympathy, and say a word, or write a letter, or do something else that would be helpful in some way. But to have the desires of our hearts there means the cultivation of the fruits and graces of the spirit.

What are these? Well, meekness comes in. How do we cultivate meekness in being a colporteur? My dear friends, it takes a great deal of meekness to start in as a colporteur. If you feel yourself very big, you will say, O let some insignificant people do that; I am too big to do that, too large a plug for the hole; I cannot get in. You see meekness is cultivated when you even begin to think about any part of the service. The Lord has so arranged it that you will have to study meekness, and have to copy meekness, or you cannot stand it at all. And you will find that you cannot get along without gentleness. It is proper that you should be meek, and in your endeavor you will find necessity for being meek in your manner, and deferential to others, which is a good quality. It will help you along; it will help you even if it does nobody else any good. And patience. It takes a good deal of patience sometimes, whatever part of the harvest work we may be in. And faith. It takes a good deal of faith. Sometimes you do not see any fruit from your work, or anything to indicate that there are any results coming. Faith in the Lord. Perseverance. All the graces of God's spirit, you see, are to be cultivated along these lines. So, as the Apostle says, if ye do these things, if you have these graces of the Spirit, if you are exercised by the Spirit of the Lord, if ye do these things, you shall never fail, but so an entrance shall be ministered unto you -- an abundant entrance, not merely get in, as we used to say, under the corner of the gate into heaven, but an abundant entrance -- open the gates wide, come in ye blessed of the Lord, we have a blessing for you; you are one of the very elect; so you have the privilege of coming into the Lord's blessed favors of the kingdom. An entrance shall be ministered unto you abundantly into the everlasting kingdom of our Lord and Savior Jesus Christ, the kingdom that is to bless the world, the kingdom that is to accomplish God's will, the kingdom that is of the seed of Abraham, of which all the families of the earth shall be blessed, and for which our Lord said that we should pray, "Thy kingdom come, thy will be done on earth

as it is done in heaven." I thank you for your kind attention.

## **2:30 P.M. -- Illustrations of successful methods of work**

*by Brother G. W. LaFerrey, Brother J. A. Cole and Brother Russell.*

SERVICE opened by singing hymn No. 80 followed with prayer by Bro. Cox.

Bro. Cole: We will now ask Bro. LaFerrey to tell us how he sells 50 books an hour.

### **Bro. LaFerrey**



Bro. G. W. LaFerrey

Bro. LaFerrey: My brethren and sisters, this was altogether unexpected to me and in my short experience as a colporteur it would not be expected of me to say much. I will say I have been in the work a little over two years. The brother said to tell you how I sell 50 books an hour; I do not do that; the highest I have ever made was something over 100 a day. A great many have doubtless done that much; however, 25 to 40 a day is about what I can do. You all know it depends upon the territory. I find it is a work that as we continue in the work we continue to learn more about it and how to get at it.

I will say this much about my methods: I make them as simple as possible; another thing is that I try to impress everybody that I am in dead earnest about the work. If we cannot impress the people that our work is worthy of our attention and that we are in dead earnest about the work, we are not apt to do a great deal in it. I have found it about as easy to sell to one class as to another, because as a general thing none know anything about it except what you tell them. Of course a great many do not know anything about it. A great many say, what is the book worth? I say, it is only worth \$1.00. Well, that is the cheapest Bible help I ever heard of. Not so; this is not a Bible, but a systematic course in Bible study. We ought to be able to give everybody an answer for the HOPE that is within us, and how we are able to go about the country and sell the books at such a low price. My experience is that in order to have an answer for everybody we must expect all kinds of questions.

For the benefit of some at least, I will say: When I go to the door and ring the bell -- if it is a gentleman, I speak to him politely and state that I have a systematic Bible course I would be pleased to show him, and the same to a lady. One of the secrets of my success is the first impression made upon the mind of the prospective customer, and in order to do that we must appear somewhat pleasant ourselves. It is a good plan to wear a smile on our faces, enough to look pleasant; then I say to them that I would like to introduce it a few minutes with the understanding that they will not be under any obligation to purchase because they look at the work. Nine out of ten of them will smile to think that a book agent would make such a proposition as that. That appears to me to be one of my best methods of making a good impression upon the people; somehow or other it unloads them of a kind of prejudice that they have. Usually book agents try to persuade, persuade, persuade. I do not feel I am a book agent in any sense; I feel that I am in the evangelistic work more than ever before; I feel I am doing a

work God has called me into, as an evangelist or colporteur. And I am glad of it, and with this thought and the grace of God in my heart, I feel able to go anywhere and say to the people that I have the truth, the whole truth, and nothing but the truth. I want to put it into the hands of the boys and girls. I usually carry the first volume in my hand, for sometime I did not use the volume provided by the Bible house with the three backs; I used to carry one volume in a little grip, but they would think I was a pill agent and they have no use for a pill agent.

I usually ask if they are identified with any Sunday school work; I want to impress them that they and their Sunday school scholars would be benefited. They ask what is it, and I do not say much, but that it is a systematic course of Bible studies, and then I say, if you are a Sunday school worker or teacher, I want to show you in the first part a chart of the ages. I ask the sister to hold one side of the chart; I have her where I want her now; she is tied up and she feels she must hold up her end of the book. Then I commence to say: You observe these arches, etc., which represent the dispensations, etc., and I give her a brief description of them. Now, sister, notice how simple it is; suppose a little boy or girl wanted to know how long it was from the flood to Christ, it is just a simple calculation in addition. And so with the other features of the chart. There is no minister in this town who can give these dates and your little boy or girl will be a greater theologian than any minister in town. The sister usually says, that is a good thing and you can put me down for three right now.

Well, we do not always meet these Sunday-school teachers; suppose a great big fellow comes to the door, looking about half mad? I usually call them brother, no matter where they come from or where they are going. I usually say, I have a fine book I would like to have you read. Well, I am not connected with any church and do not read the Bible. Oh, I say you do not know what you are talking about; here is a volume which shows that we are living 6000 years from the creation of man; the first volume takes up and treats on the creation of man, and the second takes up where the first lays down, and the second one is the one you ought to read particularly. Why is that? he says. Because it is entitled *The Time is at Hand*. We are living in a particular time when two great parties are marching together; we are living in perilous times, etc. I presume you are a laboring man, and you ought to read up on this matter. These time prophecies have told us all about these things; they show we shall have a great conflict and with that conflict all the kingdoms are going down. Well, he says, you can put me down for three now, and you can put my brother-in-law down for three.

I am telling them the facts and not lies; you want to sweep them right off their feet.

I would like to ask you a question, dear friends: Won't these volumes and Dawns be of some benefit to the world when the perilous times come, when the great battle is to be fought? Won't the worldly men read and find out for themselves? I would like to know these things. I asked Bro. Russell about it, and he said, just work right along; it is good for the development of character in each one. Well, I want to wear and be worn until I wear my life out. I never expect to be called off the field as a colporteur until God says "enough." Let all the devils in the world rise up against us. I feel we are all in the most glorious work that has been known in this world, and we have covenanted to lay our lives down in the service of the Master. And I want to say to you colporteurs and prospective colporteurs that there is a deep tender feeling in my heart for



you, and while I love all the brothers and sisters in the Truth, there is a tender feeling for every colporteur and everyone that is willing to go out and distribute tracts.

When the truth overtook me, I was in the ministry as a Baptist minister, and when I had read about half of the Dawn, I put it in the hands of another Baptist preacher and after he had read a little he said, "Bro. La Ferrey, I am getting religion as I never had it before." The first man I ever handed the book to is now in the colporteur work. After reading a little of the Dawn, I said to my wife, we will go down to the Church and I will preach the best sermon I ever knew on restitution, and I thought they would all be glad to hear it, and that we would have the finest church there was. But the brethren said, they could probably stand such preaching, but it would not do to teach it to our young people. Well, I said if you can't stand a sermon on restitution, I will hand in my resignation tonight. That was just two weeks after I had gotten hold of the Dawn. They said I had gotten tangled up at the Chattanooga Convention. You have not acted just like yourself since then -- are you going crazy? No, I guess not. So I resigned. They then went to another Baptist Church and told them, and they said to me, We will have to call you up. I said just "call." The next was I had heard that they had turned me out. They went to the association and said, G. W. La Ferrey has been turned out of the Baptist Church; and so the Baptist association turned me out also, but that did not bother me, and I was distributing tracts as fast as I could.

Then I wrote to Bro. Russell and said they had turned me out, etc., what shall I do? I believe I will buy a tent and do some evangelistic work. He said the tent matter had been a failure; so I said nothing more about it. Now the next question was, What are you going to do, for I knew I had been turned out. My son said, Well, Pa, what is the matter with you? We are being disgraced. I said, why, son? Why you cannot behave yourself enough to keep from being turned out of the church. I said, I would like to explain it to you but can't do it, I reckon.

All in the association knew that I had been turned out and when I started to colporteur they would say, aren't you the man that got turned out of the Baptist Church? Yes, I said, I am the man that got turned out of the church. Well, I do not want your books, for I will get turned out if I buy them. Well, do as you like about it; I am on the road and I am going to sell them.

I wrote to Bro. Russell for more territory and he sent me to another county where I had been pastor for three years. I got on the train and lit out and thought I would convert my old church. I had in mind one minister who used to be a very particular friend of mine, and I thought what a glorious meeting we will have. When I got there I said to him, Do you know I have got the best thing in the world? What is it? Well, it is called the Millennial Dawn. That was a dead give-away. Why, he said, we have had that book in the house for seven years; that is a dangerous book; my wife read it and she did not like it. Well, I got my grip and I left.

Those were some of the perils and trials. I said, where in the name of the Lord will I begin work; they all know me, and it seems I am an offcast to the world, etc., and the best thing in the world they will not have. That night I said, Lord give me strength and courage and I will canvass this town. So I started out and sold 160 volumes there. They said, Bro. La Ferrey, you have turned out to be a book agent and have you quit the ministry? I said I had to -- they turned me out. Then I went over and distributed all the tracts I could to the ministers as fast as I could catch up with them, but they would all run like as if I were a snake. When I did catch up with some of them,

they would say: I want you to understand that I am not led away by every wind of doctrine in the country; no, I ain't got time to read it. No, they would not read it, so I found out finally after trying everything else that I was not fit to sell anything but Millennial Dawns.

## **BRO. J. A. COLE**

BRO. J. A. COLE: I am very glad myself to see so many Millionaire Colporteurs; Millionaires in more than one sense, too. You know the Scripture says, "If we are Christ's, Christ is God's," and so as our Heavenly Father possesses all things, owns all things, the whole universe; and if we are joint-heirs with Christ, we are heirs of everything, and surely that means millionaires, doesn't it?



We have not of course all come into our inheritance; only an earnest, a pledge of that inheritance, the holy Spirit. It remains for us to be loyal, to prove our faithfulness, to see if we will come into that inheritance, if we will come up to the test laid down, which is: "Be thou faithful unto death and I will give you a crown of life." So the Lord has opened up this way to some of us to prove our faithfulness, to give us some little service as colporteurs, to see if we have some humility, to develop the fruits of the spirit. Bro. Russell told us that the Lord could do without us if He so desired, but He has condescended to us of low estate and offered us this great privilege; we cannot overestimate it.

There is another sense in which we are millionaires, richer than Rockefeller himself. How much money has he? Well, he has just enough to barely get him to the other end of his life, for he cannot take it beyond with him. Everyone then has as much as John D. Rockefeller. We are promised our bread and water. He cannot buy his way into heaven, and so we are just as rich and far more so. When we stop to consider, we have much more than we would think of on first thought and we have not much longer to live here. At the very outside, there are only seven years and if each would take inventory of what he possesses of this world's goods, it would not require much to pay our board for 84 months; that is the very limit. It may be shorter; we know it has been shorter for two of us. So if we stop to think of it, it will be far better for us not to bother with the cares of this life; we need to figure on enough to keep us for only 84 months, that is very short and that would be my way of looking at it. I am glad I disposed of what little I had and started in the colporteur work six years ago.

I have noticed how remarkably of late some of the friends have had experiences in the selling of what they possess. I remember Bor. Geo. Draper at the Indianapolis convention; he then had a farm and had not been able to sell it, but as soon as he went home from the Convention and without any effort he sold out everything at a good price and soon we expect to see him in the Pilgrim work all the time. I recall a brother and sister who just one day before the Niagara Convention disposed of their farm through the providence of the Lord and they are going into the colporteur work. Another brother had a similar experience; he had a house and lot and had been trying to sell it, but had not been able even though he came down in the price considerably; probably the Lord's time to sell it had not come, but just as soon as he returned from the Niagara Convention, a man came to him and said, don't you want to sell? And as a result he sold it for more than he had expected.

So there are ways being opened up that are our Heavenly Father's doings and I want to say as my experience that I am glad I have not many things to bother me. My house is made out of a box in which I received some books from the Bible House three years ago and it is now down in the depot.

A great many hesitate starting in the colporteur work for fear they would make a failure of it. We do not know just what we can do until we try. Some have had quite a good deal of talent to address others as Pilgrims and probably if this opportunity had not opened, they would not have appreciated this. And so the same may be said of the Colporteurs, for if we had not tried it we would not know. I have often made the remark to my friends: Well, when you see me selling books, you can put me down as being next door to stealing. But I do not look at it in that light now; I look at it from the Lord's standpoint. I remember one sister that thought the same thing, that she could not sell books, but there was one brother who kept at her all the time, urging her to try, and finally in order to satisfy him, she said, I will just go out and show you. Well that is about four years ago and she is still trying to prove that she cannot sell the books. Let us rely upon the Lord and put all of our trust in Him.

I thought a nice text for the afternoon would be Gal. 6:9: "And let us not be weary in well doing, for in due time we shall reap if we faint not."

It is a very easy thing to get weary, it is second nature. There are many ways of getting weary; maybe in getting up in the morning we forget to pray and have an intercourse with the Lord and fellowship with Him and would rely upon our own brains, etc., and would of course become discouraged. As a result we would not sell many books and might conclude that the Lord did not want us in that place, that He wanted us somewhere else. It is because we are not being exercised by the spirit of a sound mind and do not go to the Lord's Word for it. Probably many will have too much approbation, just think what people will think. Your approbation would say, I do not want to be a book agent. Think how some would look at us and ignore us; some of our friends or strangers would look upon us as a book agent, really a cast-off from society; but let us not listen to approbation.

Maybe someone might lack self-esteem, and need a little push and energy to overcome these obstacles. If we do not have it actually, let us reckon ourselves to have it. I heard Bro. Russell suggest to a sister who said she was too timid; now consider that you have self-esteem. If we had a clock and it was a half hour behind time, we would say to ourselves, it is not half-past eleven, but twelve o'clock, and time to eat. We would reckon it up to where it belonged. If you are timid, just reckon that you are not timid, but go to work, using extra energy back of it and gradually you will overcome some of these obstacles. Some also think that the people to whom we sell the books will not read them but become disgusted and say, I am sorry I spent that money for it, and so we might think if that is the way the people are accepting this book, I cannot go ahead and sell it when I feel they are not going to get any good out of it. Well, we are not responsible as to how they receive it, but we are responsible to try to sell it. I wish to give an illustration of two jewelers talking about diamonds: One said, When people come to me they have to rely upon me; they have to trust in me. The other did not think that was hardly so. The first one said, I took one of my \$500 diamonds and put it in the showcase in the window and put a label marked 50 cents

on it. People passed by for a week and not one wanted it. Well, was the storekeeper to blame? Was the diamond? No; so when we present the truth to the people and sell the book for only 35 cents, it is certainly a pearl beyond price, but if they cannot pay 35 cents we cannot do more. It is not our fault; do not get weary from that standpoint. Another way probably of becoming weary is in losing sight of the reward. This seems to be so stupendous that it is almost impossible to grasp it. Maybe we are sometimes using the truth like a toy. At first we think a great deal of it, but after a while it becomes old also. Let us not do that with the truth. It becomes more valuable with age.

It is hard to imagine how valuable that prize is. We cannot think of any people at the present time worthy of the Lord's favor. Down in the Millennial age every knee shall bow and every heart shall confess. Just think we will have an equal share in those honors. All the people from Adam will get help and strength from us in due time. You know the disciple that was nearest to the Lord's heart asked about the reward, and he said, it is impossible for me to say; all I can say is that, when He shall appear, we shall be like Him. Suffering for just a few years now is far more than worth it. Then also take, for example, some of the past ancient worthies; how they were not acquainted with these privileges. I recall to mind Daniel; he merely wanted to understand these things, but the Lord said, No, Daniel, go your way, it is not for you to know; it is for us who are living right here now. He only wanted to know about it; we not only know about it, but we have the privilege of sharing in it and having the blessing.

Take again the angels; our Lord did not offer it to them. "Unto which of the angels did the Lord say, thou art my Son, this day have I begotten thee, etc." They simply desired to look into them, but they were not permitted. We should never become weary in well doing. We are going to reap if we faint not. Again, I recall the angel in conversation with Cornelius; you know back there at that time when the Lord was on earth at the first advent, it was only for the Jews, -- the Gentiles had no share, for unto His house only was He sent. But there came a time when they lost that faith and the Lord was going to send it to Cornelius. Now the Lord sent an angel to Cornelius, and the angel said, I would just give anything if I could tell you something about this, it is something great, something incomprehensible to you, but it is not my privilege to tell you, but He sent me down here to an old fisherman, and you are to send some of your servants to Him; the great privilege has been accorded to Peter; he will tell you. Certainly this favor is with us now; we can go out and tell our Lord's blessings, that He has some plan that the angels have not had the privilege of telling. Sometimes we go to the door and they will be very angry because we rang the door-bell; some are very gruff, etc. But let us accept all of these experiences as coming from the Lord, realizing that in them all He has lessons for us to learn.

I want to read a few verses from Ezekiel, second chapter, for the Scriptures speak a little about such experiences. We expect some are going to turn a hard face to you. (Please read the entire second chapter of Ezekiel.) I want to tell you a few things about that Prophet mentioned in verse five, and to have you realize that when we join in the work, we are a part of that great Prophet. At Niagara Falls he was telling us not to overwork ourselves -- four or five hours would be about all we could stand? I want to tell you the example that he sets; I could not tell it properly if he were here, but he is not, so I am going to tell you a few things, and I am in a position to know a few things about him and I am glad I do. It was my inestimable privilege to be at the Bible House about six months a year ago, and have the pleasure of sharing Bro. Russell's room for that time. I know him pretty well; you know you like some people pretty well, but after living with

them for a while, you do not like them so well, but the more you live with this prophet the better you will like him.

About forty years ago a merchant in Pittsburg refused to rent Bro. Russell a store room for a year, the reason being that Bro. Russell was so weak and sickly that he would not live the lease out; that was forty years ago. Even now he does not enjoy much better health. Sunday, when he was speaking for two hours, there was not a second that he was not going through pain on account of a headache. He has a headache at least half the time; he has headaches so severe that his eyes will swell up, but he has not been in bed a day of his life. He would get up, I should judge, about half-past six in the morning -- I do not know how long he was laying awake before that, thinking of plans, etc. He never went to bed before eleven o'clock; then to think of two-fifths of his time at night is spent on railroad trains. That is the way he works continually from morning until night. He begins after breakfast in his study dictating to stenographers until noon; after dinner he continues his work until supper-time, then goes down to the office on the first floor and signs letters, etc., eats supper and then works again until 10 or later, never stopping before ten. That's the way he puts in time! That is a noble example of the way he is laying down his life. That is what Ezekiel tells us about. As far as money goes, he would have been a millionaire if he had followed that inclination; he has not a cent of his own -- everything is in the Bible House name.

You remember the three signs in the Tower, not long ago. The first sign mentioned being applied to the first tract; these cost \$45,000 of his own money, and they were sent all over the world. Of course we do not know how much he has given because he does not tell these things; he did not tell me these things, but they just leaked out.

I cannot but help compare him with Voliva, who has been at Zion City, Ill. Voliva said, Why here I am preaching to you people and getting only \$100 a month and you do not seem to appreciate me -- which one is that prophet from the Lord?

Notice the third verse, the first part, "And He said unto me, Son of man, I send thee to the children of Israel." Taking it in the secondary sense, we are not sent to the heathen, but to the nominal Church of Israel; "to a rebellious nation that hath rebelled against me." You see they are rebelling against the Lord and not us; "they and their fathers have transgressed against me, even unto this very day." You see how true it is, that is the principle of God. They say to us, "Why don't you go to the slums, etc." Do not pay any attention to them, the Lord said, "I send you unto them." We are to preach to them whether they will hear or whether they will forbear, because the Lord intends they shall know there hath been a prophet among them. In the 8th verse, the Lord tells us not to be rebellious like that rebellious house, but to open our mouths and eat that which He gives us. Sometimes we are very surprised when we meet a preacher how easily we have been able to answer him, and we say, the Lord has done this and has made our foreheads hard. Fear not, neither be dismayed at their looks though they be a rebellious house. No matter how much they scold at you, do not get weary in the work because of that.

I remember when canvassing in Zion City, how the people there seemed to be looking for the truth, etc. I recall one lady how she would like to have the book but had no money at all; she said, my closet is hanging full of silk dresses, etc., while she was going out into the country

peddling potatoes. When they came there they had lots of money. The Lord has given us this truth and this privilege of proclaiming it, and how happy we should be. We are receiving a hundred fold even in this life.

I recall one experience when Brother MacMillan and I were working in the country towns, we had a standing joke, when coming to a place, we would see first a steeple, then a grave-yard, then a saloon. I recall one town with not much more in it; we canvassed the town and sold two books. Brother MacMillan sold one to the saloon-keeper and I sold one to the preacher; the saloon-keeper paid for his, but to this day I have not gotten a cent from the preacher. Let us always look on the bright side and not lose sight of the reward promised.

I mentioned at the Niagara Convention how it would be a fine thing if you would just go out with each other and in the spirit of love and with a desire to help each other, criticise each one's canvass and methods. (See address to colporteurs in Niagara portion of this report.)

Another thing, look neat and clean, keep your clothes pressed up. It is not so necessary that you have expensive clothes, but that you keep them neat and clean. However, a good suit of clothes will last longer and keep their shape much better than a cheap one. I usually press my own clothes every Saturday night. When in a country town we cannot do that very well. Brother MacMillan and I had another scheme in those places; we would lay our trousers down smooth on the springs under the mattress and sleep on them and in the morning they would be pretty well pressed.

About keeping the book out of sight, some say they do not find it convenient to carry the book in a little bag; probably they had the bag on the wrong way. I keep the book out of sight because I do not want the people to think I am a book agent. We are not deceiving them, but are really justifying ourselves. All I wish to do by keeping the book out of sight is to hold their attention until I can secure myself and show them that I am not a book agent. As soon as I have shown them that, then I bring out the book. Regarding the introduction, where the people are hard to get hold of, make the introduction a little longer. I talk in a low subdued tone; it is more in keeping with the truth that we are presenting. I use a great deal of inflection in my voice, and expression in my face. Let them see that you believe and mean every word you are saying.

Here Brother Cole gave an illustration of his method (see method as given in "Hints to Colporteurs" as sent out from the Bible House; also notice the method, somewhat modified, as printed in Part I, contained in report of Indianapolis Convention).

I make use of three particular points; the enormous circulation, not a book outside of the Bible has such a circulation; second, it is sent out by a Bible society, and if it were not good, the Bible society would not sell it; third, then you see the price is only 35 cents, we are not getting rich, etc.; these books used to sell for \$1.00 each. I also sometimes speak of the binding and say, see the spring-back, it is not going to fall to pieces. I also refer to the print, large type, etc.

Perhaps some will say they have no money. I reply, well, we sometimes do like this: We take your order for just the one volume, all these subjects of importance are complete in this one

volume, the address of the Bible Society is here and you can send to them yourself for the others. If they will not take one volume then I try to sell the "Za."

Perhaps after giving the canvass, they will answer in such a way that I will not say another word about the book but give them a tract and leave them pleasantly. Do not talk and lose time by casting your pearls before swine.

## Practical Advice for Colporteurs

### BROTHER RUSSELL:

I am glad to see such a large company of colporteurs and friends of colporteurs and I presume sharpshooters, too. I was very much surprised to find that so few had made application for territory. I must suppose that you have already applied to the office or else there are very few new colporteurs at this convention who are thinking of entering the work.



**A cheerful face:** This is very important, some that are the most successful nearly always have something cheerful about their faces. There is no excuse for any of us not having a cheerful face, it does not cost much; you have plenty to make it with; you have the TRUTH. Do not get alarmed when you go to a house to offer the books; you are on a mission of love; you are an ambassador for Christ. I would not like to give anyone such an opinion as would puff him up, but from another standpoint, it is very important that we realize that we are serving the Lord Christ, that you are in the most honorable business you could engage in. You are ambassadors for God. You know how honorable the ambassadors are considered in the various countries; they usually get a good salary and are often exempt from certain laws.

About the happy face, I want to bring in here an item; you cannot have as happy a face after you are all worn out. Therefore when you get to a point where you are weary, stop and go home and rest. Well, you say, I can put in some more energy. If you do, you will just as likely take that much off somewhere else and will have just that much harder work to recuperate. I speak specially of the sisters -- some cannot go more than one hour, while others can go for six hours. Some say that while working two hours and having the remainder of the day for something else, they will go forth the next day so fresh that they will take more orders in two hours than they would in four hours if they were tired.

When rested you are all interest, you are animated and you can make the proper impression upon the people.

I think of one brother that was not very successful, and I asked him to show me what his method was. His method was while speaking at the door, he wished to appear very offhand and he would look up and down the street, and so would the customer. Now I said, brother, you have the wrong idea, you do not want that man to look up and down the street, but to look at the book, the book, the book -- you do not want the dogs or cats or anything about you while talking, that would attract the attention away from the book. Fasten his mind, you want to help him to centre his mind upon what you are telling him, you do not want to help him think of anything else.

I think of another brother, he said he could not take any orders at all; so I said, tell me how you do it, and he showed me. Brother I know your difficulty. He was a New England man, they talk very rapidly and if

you are acquainted with them, you can follow all you can understand, but if not, you would not know a word of what he said. Someone would come to the door and he would say, trrrrrrrrrrr. They would say, I don't wish any, thank you. They did not know anything he had told them. In the country, people do not hear much talking and do not talk much, so you must talk slow. In the city people are different and you can talk faster. If you happen to live in the country, you want to get up steam and talk as fast as you can; if from the city, tone down your voice.

**Rest:** A great many need to know what every person ought to know and particularly the sisters, that is to say; when we get weary all of our muscles relax and not only affects the muscles of your arms and limbs when you are tired, but your abdominal muscles and internal organs and when you get tired, you ought never to lie down in that way; it is altogether wrong, and you are very likely to get up just as tired as when you laid down. Before lying down every night, or any time, you ought to lift the abdominal parts in your hands so as to relax and take the weight from the cords which are elastic. When very weary they are quite stretched out and when you lie down that way you may get up the same and if you keep that up, you will soon not be able to be in any kind of work, especially the sisters, housekeepers, colporteurs, etc. Lift up the abdominal organs, lie down then let go; you have relaxed them. During the night, nature restores the organs and in the morning you will feel you have gotten the good of the rest.

**Food:** Another important thing is food, you cannot be a good colporteur without eating. Some of the dear friends when they think of economy, think they want to do everything economically. All I am speaking of is that you need food, good food, wholesome food, you cannot afford to take the unwholesome kind. What you want is wholesome food and good food taken regularly and chew it well. God gave us teeth for the purpose of masticating and saliva to help digest the food. But if you swallow your food without chewing it, but washing it down with coffee, etc., you will get dyspepsia and the same if you eat too fast, eat with deliberation and also with thankfulness and an expression of thanks to the Father.

We have already suggested to some of the friends that molasses candy such as you know how to get, is sometimes very good for food, it is very refreshing, you can get a kind of molasses kisses put up in paraffine paper. Take one of those and you will be surprised how quickly it will give you energy; in five minutes you will feel better. Strange, but it is a fact, the governments of the world have found it out, and they are providing candy for the soldiers in the German and American armies. It is found to be a very good thing to bring refreshment to the system quickly. Not that you could live on candy, nor that you should eat all kinds of candy; some is very injurious. I am speaking of the plain molasses, the best kind. You will also find that certain kinds of chocolate is very wholesome and nutritious, it gives nourishment very quickly. Keep in mind food of a good kind and that it should be eaten with regularity. When you are out soliciting, not only your feet have to carry you, and you have to spend energy in walking, but your mind is on the alert and you are using up energy with your tongue, brain and limbs. You are using up energy more than the ordinary people are doing.

**Business Details:** I wish to mention a few details that will be helpful to you and to the workers of the Bible House: Write plainly, give full name and address of those to whom you want Towers and tracts sent so they will not go astray. Always give your own name in full, do not sign your letter, "Sister Ida." I know that everyone in the Watch Tower Office is a child of God and glad to lay down his or her life in the service, but it makes unnecessary work if you do not give full name and address etc. The work at the Bible House is divided among various departments and if you do not give full particulars in your letter, it necessitates going from one floor to another and consumes a great deal of time which might have been saved by a little more care on your part.

**Be prompt;** it is not necessary to hold your report and sheets until you have made the delivery of the books; these names are the names of those whose orders you have taken, no matter whether they take the



books or not. Just put down all the names of those who order and let it go at that.

In referring to previous communications always give the date. Why? Some write in and say, the last lot of books I did not get. When that letter comes to the office one says, do you remember? No, I do not. We have to ask several people when and where it was, etc., and have a great deal of trouble to hunt up the last order. State what date it was, keep a copy of every order. Some who did not keep a copy, write in and say, their order was so and so, but on looking it up we find they did not order what they now claim; they thought they did, but did not keep any copy. Examine your books at the time they arrive, do not wait and say that the books I got last August or July did not all come. Tell us at once for we want to correct the matter at once. See that the balance is all right, do not wait a month afterwards and tell us, but write at once for it saves you and saves us trouble. Write full name and address at the head of each letter.

Use colporteur envelopes or if you do not have one, write the words "Colporteur Department" on the corner of any other envelope. The reason that colporteur envelopes are provided for colporteurs is that, colporteur mail receives the quickest attention, for their business is important and they are all more or less in a hurry, and if your letter is otherwise addressed, it may be a day or maybe three days later. At Christmas time we may have a thousand letters delayed, which does not matter a great deal, but we want the colporteur letters to have prompt attention; therefore use the colporteur envelopes. You do not need to write on this envelope, for it is already printed on them. If you get out of these, just write "Colporteur Department" on any envelope. If you use a postal card, do the same with that.

**Remittances:** When you make a remittance or a Money Order or an Express Order, always put it down on your order blank, which is furnished and also enter in the remittance so that it is all there. If you do not, it may make trouble for you and for us. If you make a mistake and someone in the department makes a mistake, they are multiplied.

**Keep a Copy:** If you have a small piece of carbon paper, so that you could keep a copy of your letters and orders, it would be an easy way and would be very helpful when making reference to any previous transaction. That is an easy way and the best way, for you then have an exact copy, but if you do not have any carbon paper, make a copy anyway for it will take only a few minutes to copy it.

**Tower Subscriptions:** When Tower subscriptions are not marked (NEW) on the front page of the order blank, they will be considered (RENEWALS) and you will be charged 90 cents each, as all colporteurs are allowed 10 cents for renewals. For all new subscriptions, colporteurs are allowed 50 cents. In order to have any recognition as new subscriptions you want to have on the order blank the word (NEW) in the proper place and mark it 50 cents; otherwise it will be understood to be a renewal. We do not have time to go and look up everyone, it would take up more than ten cents of time; because one party takes charge of the subscriptions and another party in another part of the building, quite a distance away, takes care of your order.

**Addressing Communications:** Communications should be addressed to the Watch Tower Bible & Tract Society and not personally to anyone in the office. If you have any personal communication, that of course is a different matter, but no personal letters go into the files. If you should ever want to address me personally, mark it "C. T. Russell, Personal," so it will not be a part of your communication to the office.

**Delayed Shipments:** If you should find that your books do not come within a reasonable time, advise us; do not wait too long. We have suggested on the bottom of the bill a reasonable time to wait according to the distance from Pittsburgh, otherwise let us know and we will trace it to see where it has been delayed, to see where it is and why it stopped. Do not hesitate to let us know, for we want to do all we can to help you.

**Conclusion:** I want to tell you in conclusion that I have a very deep sympathetic love for all the Lord's people, but want to say that I have a special love for some. You know Jesus loved certain ones: Martha, Mary, Lazarus, Peter, James and John, and Jesus spoke about John whom he specially loved. It is not wrong to love some more, you cannot help it. Why did Jesus love Peter, James and John more? I think it was because they were the most energetic in the Lord's service. I find myself naturally loving those whose love for the Lord is of the practical kind. So when I find one laying down his life for the Lord, I love him most. I think the Lord does and that He is willing I should, so I have a special love for those who are actively engaged in the Lord's work, those who are engaged as Pilgrims, Colporteurs, Sharpshooters, Volunteers, those that are making contributions, etc; these all make a special appeal to my heart. So to all who are here, I feel that I am addressing those; I am addressing some that I specially love. If ever in trouble, write to me, but first write to the Lord and then to me. I am sure the Lord will take care of the matter and then I shall be glad to do anything in my power.

This colporteur session then closed by singing hymn No. 23. "Blest Be the Tie."

## **7:30 P.M. -- Colporteur Praise and Testimony Meeting.**

Led by Bro. Frank Sherman. Meeting opened by singing 132 -- "I Will Sing of My Redeemer." This was followed with prayer by Pilgrim Bro. Sampson.

Bro. Sherman. Just as I was coming to the platform, a brother asked me if I was going to run the meeting. No I am not going to run the meeting, all I hope to do is to get it started and it will run itself. We know that our Lord is here, that He is listening to us and that He is pleased to listen to the friends. This is Colporteur day and this service is particularly in the interest of the Colporteurs.

By way of introduction, a thought was suggested at the Niagara Falls Convention, in the words of our Lord in the 24th chapter of Matthew, where he speaks of the eagles being gathered together, and the thought was that the Lord's people are likened unto birds. (See similar remarks in Niagara report under heading of Colporteur day.)

As to my testimony, I will give part of my experience while canvassing at Philadelphia. I knocked at the door of a house and a little girl came to the door and I asked for her mother, the lady came to the door and as I began my canvass, I opened the book and a man came from another room very much incensed and said, "Get out of here, if you do not get out, I will give you a smash in the face;" I began to back away and get out of the door, and as soon as I got out, they slammed the door. It was, however, my privilege to bring the truth to a number who were hungry and thirsting after righteousness. The great lesson is that we should be properly exercised by all these experiences.

A brother: My greatest troubles that I have come to me from the ministers, they say we are getting tired of these people who are building up two by four churches and taking the best people out of our churches. Pray for me that I may be more able to bear the persecutions and that I may consider it an honor. A brother in Chattanooga said to me, "The Lord is going to let some of the preachers around here give you a good beating if you are not careful." If the Lord will spare me a year longer, I hope to grow up to be able to bear these things.

Bro. Sherman: If we do get a beating, we can remember that the Apostle Paul got stripes, but we want to be sure that we are not getting the beating because of our own indiscretion.

A brother: I had one experience, a man said to me, I saw you go into that house, you saw an old lady in that house and you thought you would take advantage. You get out of here before I give you a black eye. I was trembling and so walked around the block and prayed to the Lord for strength to keep my temper down and be calm and gentle before I approached another house.

A brother: In the colporteur work you will find some of the coldest and some of the warmest receptions. These warm receptions are worth all the hard ones. I find I need all the experiences that the Lord gives to me.

A Sister: My heart rejoices that the Lord has opened my eyes to see His wonderful plan. My experience is different from others; I have not had many unpleasant experiences. I often have them say to me, I do not understand why I invited you to come into my house, for I never allow agents to come into my house. I realized that whatever it was, the Lord helped me.

A brother: I can say the Lord has richly blessed me in the colporteur work. I have been in it a little over a year now. When I hear some of these unpleasant experiences they make a deep impression upon my mind, and by telling some of them, they may frighten others from going into the work. I want to tell you that they do not come very often, they are rare. They make such a deep impression because the old man always gets control. I have found that the pleasant experiences are specially interesting, when we find someone that is interested in Bible study or someone who has been reading Volume One, sold by some other brother a year before, and are longing to understand and are wanting to know more. I have found a number of such and I have had grand experiences in trying to explain things further to them. I have found that such experiences come to me on the days that I have sold the fewest books. When I do not have much success I say to myself. I wonder where that grain of wheat is that I am going to find? Another suggestion I wish to make, when a brother asks us to pray for him, we cannot remember to pray for them individually, so let us at the moment he makes the request offer up a silent prayer.

A brother: In contemplating the colporteur work, it is not necessary to see how we are going to make our expenses, etc. I had a wife and a little child and about three years ago, I had the opportunity to start in my own town of 75,000. I had a twin brother who was a mail carrier and he asked me not to sell the books in his district, but I paid no attention to him. One woman said, you have been so good about bringing my mail that I will give you an order. After that I started out with my wife and we have been able to make all of our expenses. At the present time our little girl goes to school and we are getting along very nicely. If you have an opportunity to do a few days' work, let us do that and see how far we can go. The Lord will bless our efforts. When we do not get an order, let us be sure that we leave a good impression. In one town a minister started a lady out following my wife and talking against the books. The people believed my wife because of her sweet manner and the good impression she made and they said that if the work was not right she would not be out selling it.

A brother: I esteem it a great privilege to be in the colporteur work, I have been in it for four years and it is the most blessed time of my whole life. We have some pleasant and unpleasant experiences, but the Lord says they are all going to work together for our good. We had an experience in one town, we sold nearly 500 volumes and when we came back to deliver, we found the minister had made quite a stir, he had denounced them publicly and had a large article in the newspaper and when we came to deliver, the telephones of the town were kept busy by the different people telling one another that we were there with the books. They said we had misrepresented them. We said that if they had been misrepresented that someone else must have done so for you will find the same subjects, etc., just as we stated. As a result we delivered over 400.

A brother: I never knew what it was to earn a living, the money just came without any effort on my part. When I started out the weather was 14 degrees below zero, but I had the little redback book under my arm, but the Quaker Oat smile disappeared and did not come back for a week. I am glad to say now, however, that I am more interested in the colporteur work and hope to be actively engaged in it very soon.

A colored brother: I do not have trouble to get into houses but my greatest trouble is in delivering; sometimes going twelve and fifteen times to deliver one volume, so you see I have had great opportunity to develop patience.

## **WEDNESDAY, OCTOBER 2.**

### **5:30 A.M. Sunrise Prayer and Praise Meeting, led by Brother Russell.**

WHEN we entered the hall at 5:15 A.M., there were fully 100 persons present. Promptly at 5:30 Bro. Russell stepped upon the platform and there were by that time 225 present; before the meeting closed there were over 400. The service opened by singing No. 19, "Awake My Soul to Joyful Lays." This was followed with prayer by Bro. LaFerrey. Then we sang hymn No. 206, "O, How Happy Are We Who in Jesus Agree."

Bro. Russell: Dear brothers and sisters, I am very glad to greet so many of you this morning and to see that so many of you enjoy the prospect of an early morning prayer meeting.

As I saw a number of you headed this way as I was coming to this meeting, it made me think of some of the reasons that draw us together. I was reminded of the words of the Lord, that in this day, pointing down to the very time. He said we would all be gathered together, the disciples said, "Where Lord?" and He said, "where the carcass is, there will the eagles be gathered together." So, one reason we like to meet together in conventions and on every occasion is because the Lord seems to give us something special to eat where we are in fellowship, where two and three are gathered together, etc., so when two or three of us meet in His name, we may be sure of His blessing and a refreshment of spirit.

In this morning time, more than at any other time, though it has been true throughout all the ages where His people met, but now early in the new morning, when, the new day, the grand Millennial Day, He is inviting us together; He tells us that there will be a great gathering, all the wheat from the tares, all the sons of God, that glorious gathering, which will mean the establishment of the Kingdom of God, out of which will flow all the blessings of God to all the families of the earth. So we have many reasons for thankfulness this morning as we think of the blessed scripture references to this morning time in which

we are living such as, "God will help her right early in the morning." You remember a picture in the 91st and 45th Psa., and how the Lord in the 45th Psa. tells of the time of trouble. As we see that day gathering all about us, we hear the Lord's word coming to us with special emphasis and we will not fear though the earth be removed, though society be shaken and the Kingdoms be carried into the midst of the sea, because we have made the Lord our habitation. In this connection the Lord tells us He will help her, the church right early in the morning. How precious the thought that we are in the early morning, when the shadows are fleeing and we can see more clearly than they could in the centuries past. It was not the Father's purpose that the special light should shine then, they had all they needed as saints of God that they might be separate from things of this world, but it was not the time to give the glorious sunlight of truth as now. Thus, dear brothers and sisters, if any fail to get that thought, they fail to get one of the most inspiring thoughts of our time, namely: that the light of the truth which you and I are now seeing is not that you and I are brighter than other men to see it, but it is God's due time -- it is morning time. Why can you see brighter than you could an hour or two ago? Because the great sun has begun to shine upon the earth. Is that all we shall have? Oh, no, that is only the early light. Bye and bye the great sun of righteousness with full power, strength and light will fill the whole earth with the Glory of the Lord. How glad we are that the blessed day is already dawning, what a blessing it has brought into our hearts; we cannot feast on that thought too much.

I might tell you without any injury to any of you about a dream that I had some years ago that had great influence upon my life. Now do not mis-understand me, I do not wish to commend dreams, I think many are nonsensical dreams. I have had many myself, probably from indigestion. I know of a great many people who lay too much stress upon dreams. I pay very little attention to dreams, only so much attention as would be in harmony with God's word, so as to feel sure the dream came from neither a piece of pie nor inspired by the adversary and I think a great many dreams are inspired by the adversary. I think a safe course is to let no dream have any influence upon our minds except as we can prove them by the word of God.

That is our standard. If it agrees not with the word it is because there is no light in it.

But this dream that I will tell you about may help some of you. I might remark that at the time I had this dream, I was giving attention to the Lord's work to some extent, I was publishing the Truth and some thought I was neglecting my business. I had five stores at that time, and people would say I guess Mr. Russell is fanatical on the subject of religion. I knew I was not, so was in no danger. I thought I was not giving enough time, that I ought to give all my time, and this dream helped me.

I dreamed that I was in an attic room, the front looking to the east, and the ceiling was sloping and I thereby knew it was a top room in a house. All around the room was a platform raised about ten inches and on it were mattresses strewn and upon them bed coverings of various kinds; some had been occupied and were vacant and others were occupied by sleepers, and I was in one corner. Over yonder was a door on the right. I heard a knock that awakened me and I remember how sleepy I felt, I could hardly get my eyes open. There I saw a servant, one that I never saw or knew, he said they are waiting for you for breakfast and they sent me up to see if you were coming. Oh! my, it is late, I have overslept myself. Tell them not to wait for me. With that I thought to get up, but as I started to rise, I was heavy with sleep and my foot caught in the arm of the man sleeping next to me and I went sprawling. I thought well, what will he do? But he was sound asleep, my falling over him had not awakened him. Something in my dream told me that it was Sunday morning, with that I awakened.

What did it mean? Well I might take a meaning out of it, that might be in full accord with the truth. I said first of all, this is an upper room and the Lord speaks of housetop saints. Well, then I am glad. Seemingly I was amongst the housetop saints, I was glad that I was not down in the basement. Then it was Sabbath morning, early in the morning. The sunlight was coming in, all that fits well, the sun is

coming in and it is time I was thoroughly awake. Then the empty beds around us, yes, yes, so far as we know, most of the housetop saints have gone in, here a few of us still sleeping; in a dozing way overcharged with the cares of this life. Well, you remember how tired and sleepy you feel almost as if you had been intoxicated. Yes, well that is a good deal the spirit of the world. You are glad you got awake, you felt so stupid, but still next to you was one still more so, and even your falling over him does not awaken him. You are glad you are awake and did not need a knock. What was that you told the servant? Have me excused, tell them not to wait for me. Our dear Lord has provided a bridal feast, not a supper or a dinner but a breakfast. So I knelt down and asked the Lord to wait on me for a little; I determined to be more earnest and diligent in His service. So I say that while I do not attach much weight to dreams and consider most of them fleshly and of the adversary, but if we think upon them and the words of the Lord, and accept nothing but what will agree with the Scriptures, we may get a good lesson from it.

Well, we are house-top Christians; we have heard the knock informing us that it was morning, that it was the time of the feast and informing us that there is but little time to get ready. We have heard the knock and how glad we are. Yet we find some here and there who are still asleep. Let us help them also to hear the knock that it may go to all parts of the world and let it not be said that there were some in some parts of the world to whom you failed to give the knock. The Master said: "Behold I stand at the door and knock, if any man hear my voice, and open the door, I will come in to him, and will sup with him, and he with me."

So we have heard the knock and already on this side the veil we have entered in and are getting some of the food and refreshment -- how glad we are.

The whole world, a greater part of it, as we came here, are still asleep. Some others are awake besides ourselves; you saw the butcher and the baker and the milkman and others all busily engaged looking after their dollars and cents and that was proper in its way. We also have a business, we have left the world behind, we have become new creatures in Christ Jesus and we must be about our Father's business. A principle proper to apply, how energetic have you and I ever been in the affairs of earth in our scramble for dollars and cents? In that proportion let the Lord see that you will be no less energetic in the Spiritual. Some say Brother Russell, you work late and early; well I used to work late and early for selfish interests, I now have something I love far better, why not work late and early in the Lord's cause as well as in the early interests? If the Lord should find that I was careless of His interests in comparison of my previous experience in life, what would He say? It would indicate that I would love the earthly more than the Heavenly. We do not want Him to say that we ever loved earthly things more than the Heavenly. We are not children of the night, but of the day, let us walk in the light.

Ye brethren are not in darkness that that day should come upon you as a thief, but it shall come as a thief and a snare upon the whole world and they shall not escape. Ye brethren are not to fear or measure yourselves from a worldly standpoint. They have no hope such as we have. Surely, very few persons hope as we do. What manner of persons ought we to be, said the Apostle, in all manner of conversation, etc., hastening to that glorious time which shall be ushered in by the great time of trouble, the time of refreshing from the Lord, because the times of restitution shall then be near.

I am glad that we have this blessed privilege of meeting this morning.

Then a prayer and praise service followed:

No. 152, "A Thousand Years."

Prayer.

No. 318, "Watching for the Day."

Prayer.

No. 72, "Hail to the Brightness."

Prayer.

No. 316. "Watchman, Tell Me Does the Morning of Fair Zion's Glory Dawn?"

Prayer.

No. 14, "Only Waiting for the Dawning."

Prayer.

No. 282, "Let the King of Glory In."

Prayer.

No. 21, "Christian the Morning Breaks Sweetly O'er Thee."

Concluded with the Doxology,

"Praise God, from whom all blessing flow,  
Praise Him, all creatures here below;  
Praise Him aloud with hearts and voice,  
And always in His Son rejoice."

## 10 A.M. -- Praise and Testimony Meeting

led by Brother Van Amburgh, opened with Hymn No. 166: "Love of Jesus."

Prayer by Bro. Graham, then hymn No. 95, "More Christlike."

Bro. Van Amburgh: I would suggest that each one preface each testimony with a text of Scripture. All have received from the Father's table these rich truths, let us hand them around to each other.

The text that I am going to suggest, not because I love it the best, is "Whereby are given unto us the best promises" (that is the literal Greek). Good promises for the world, better promises for the Jews, but the best promises are for us. And by laying hold of these by faith, we may become partakers of the Divine nature.

Why should he give us the best? He said, "Because I love you; as the Father loveth me, so have I loved you" --

A brother: 2nd Timothy 2:21, "Wherefore if a man purge himself from these, he shall be a vessel unto honor, sanctified and made meet for the Master's use."

A brother: "Now the God of peace, that brought again from the dead our Lord Jesus, that great Shepherd of the sheep, through the blood of the everlasting covenant."

This has been a very precious verse to me; when we see the high standard, we are apt to become discouraged, but we are to realize that we are not doing this in our own strength.

A brother: "He that hath left father or mother or houses or lands," etc. I live in a place of 10,000 and have been in the truth five years and am still alone. When I left for this convention my wife would not say good-bye. I tried to get my daughter to come to this convention and I am glad to say she is here, and I hope some of the prejudice may be removed. If the prejudice in our family cannot be removed by the other members of my family seeing as I do, then it will have to remain, for I cannot worship as they do.

Bro. Van Amburgh: I would suggest another text, "Let your light so shine that other may see your good works." I had a similar experience, when I tried to preach to others for whom I was working, but they did not pay me for that, so I found a better way was to let them see by my daily life.

A brother: "Sanctify them through thy word, thy word is truth." I love the word, the Lord opened up the way that I have had my prayer answered. This is my second convention; they are all good, but they grow better and better. I love all the brethren, yea I love my enemies.

A brother: I love to keep my eyes open to see things around me; yesterday I went to the exposition, and the thing I saw there that made the greatest impression and probably the best part of the exposition caused me to think of these texts the Apostle Paul uses in the 8th chapter of Romans -- the whole creation groaneth, etc. That exhibit was the display made by the U.S.



Government in the Army and Navy Department. When I saw that display, I thought, "Thy Kingdom come, thy will be done on earth as it is done in Heaven." The grandest display that humanity can make is their instruments of slaughter. I saw one gun rigged up to kill 800 men every minute, another gun cost \$1,500 every time a shot is fired, and it is capable of sending a great war-ship to the bottom of the sea. Surely the world groans.

A brother: I have gotten a great lesson from Bro. Van's remark about letting our lives shine forth telling what and who we are when we cannot tell them by talking. Perhaps I have talked too much. I told the minister that he would have to cut the tongue out of my mouth if he wanted me to stop talking, for I cannot help talking of this glorious truth.

A colored brother: "Ye are my friends; if ye love me ye will keep my commandments, and greater love hath no man than this that he laid down his life for his friends." I am thankful that the Lord has permitted me to meet here. He has revealed the secret of His love to some people and I am so thankful that the Lord has called me to be one of the anointed. I have learned more of the Bible since I have gotten hold of the Millennial Dawn than from any other book.

Bro. Reed of Chicago. I would like to sing this song as my testimony.

### **"My Greatest Desires."**

I want to know Jesus, my Savior so dear,  
Far better than loved ones below;  
His heart I would find very gracious and kind,  
His fullness of love I would know.

I want to be like Him, my Savior and Lord,  
So patient and tender and true;  
I'd walk as he walked, and I'd talk as He talked,  
And gladly His will I would do.

I want to see Jesus in beauty arrayed,  
The glorified Savior so fair;  
In mansions of light, Oh, so beauteous and bright  
I want in His glory to share.

The greatest desire of my life are these,  
That I may know Jesus divine,  
And like Him to be, His glory to see,  
And in that bright image to shine.

A brother; "Blessed are the pure in heart for they shall see God." What a grand and glorious thing the DIVINE nature. Who gives it? God Himself. How? By becoming overcomers. How? By being pure, emptying ourselves of ourselves, crucifying ourselves, being prepared to receive the holy Spirit.

A sister: "Kept by the power of God through faith unto Salvation." This is not so much my testimony, but for a dear isolated brother: While the convention was in session at Niagara, I was at a convention of three, a brother who had been in the Truth for nearly 20 years and until the day I went there, he had never met with any of like precious faith, but with that brother and Bro. Streeter, I had a grand time of fellowship. She then read a portion of a letter from this brother which indicated his love for the truth and his gratitude that it had been made known unto him.

A colored brother: I cannot find words to express my gratitude. Fifteen years ago I told the people that I was converted, but four years ago, when I received the Millennial Dawn, I found I was not converted.

A brother: I did not intend to testify but I cannot keep still. I want to say how much I was helped by a discourse by our dear Pilgrim Bro. Paul Johnson at Niagara on the subject, "Walk in the Spirit and ye shall not fulfill the lusts of the flesh."

A brother: The brother that just spoke, has taken the text out of my mouth? When I heard Bro. Paul Johnson at Niagara, I just thought I would appropriate that sermon all to myself. It was grand to me. I applied it to myself individually. For many years I had been trying to keep this old body down, but continually he would rise up in spite of what I would do, and I saw my mistake as soon as Bro. Johnson spoke on that subject. I was fighting the old man right along when I saw that the two natures run opposite to each other. I pray for more of His Spirit and I find my faith is increasing, and I can say as never before, Praise His name for this grand salvation.

A colored brother: I am so glad to understand something about our Heavenly Father's plan. I did not know it in the past, but since the Heavenly Father has been pleased to open up our understanding, it has filled my heart with love and gratitude. This hope caused me to attend this my fourth convention.

A brother; Sing No. 113, "I Love Thee" for my testimony. The Apostle Paul thanked God for what he was, but I thank God for where I am.

Bro. Fowler: "Ye are our epistle written in our heart, read and known of all men." We are receiving great blessings; I wonder how many blessings we are going to take with us? How are our lives speaking to others? I think this is very important. The time is short, let us use the little that is left in perfecting our characters.

A sister: "Be ye steadfast, inasmuch as your labor is not in vain in the Lord." I know that I have passed from death unto life, because I love the brethren, and it is growing deeper and stronger every day of my life.

A brother (formerly a Jew): Phillip opened the Scriptures and preached Jesus from top to bottom. And that was the main thing in my mind of the work that was done. After the baptism, Phillip was taken away and left the Eunuch to lean upon Jesus whom Phillip taught. When I received the first three volumes, I not only read them, but I ate them. Then I hunted up the friends that believed that way, and I rarely miss an occasion to meet with them.

Sisters Nation sang "Saved by Grace."

All who had not had an opportunity to testify were asked to rise while all sang No. 277, "Take My Life and Let it Be."

## **2 P.M. -- Discourse on "The True Baptism,"**

*by Brother C. T. Russell.*

This service was held in a large and beautiful edifice used by one of the Baptist congregations.

Bro. Thompson (Colporteur) presided at the large pipe organ. After the singing of several hymns appropriate to the occasion, Bro. Russell addressed fully 700, who listened with close attention to the discourse on the subject above mentioned. Fifty-three then symbolized by water immersion the burial of their wills into that of Christ.

## **8 P.M. -- Discourse**

*by Pilgrim Brother J. A. Bohnet, of Allegheny, Pa.*

**Topic: "The Righteous Like the Palm Tree."**

BRO. BOHNET said, in substance:

Dear friends: Our text is found in the 92d Psalm and a portion of the 12th verse, reading: "The righteous shall flourish like the palm tree," and a portion of the 35th verse of the 37th psalm, reading, "The wicked . . . spreading himself like a green bay tree."



As we read the Bible and meditate upon a text, I fear many of us do not give the subject sufficient thought. We simply skim over the topic, or the sentence, getting only the surface, whereas if we would only dig down deep into the matter, we would get a wealth of meaning from almost any sentence in the precious Word. I know how it was when I was a lad, there were numerous texts of Scripture brought to my mind in my youthful days that I did not get the full sense of until long years afterwards. One of those texts was about the rich man's difficulty to get into heaven, and how much easier it would be for a camel to go through the needle's eye. I did not understand that, because I did not know that the needle's eye is a small gate alongside the large gate in the walls of ancient cities, and therefore my mind was confused, and I thought how impossible it would be for a rich man to enter into heaven at all. But as I understood the facts upon

which that statement was based, I of course grasped the meaning in its fullness.

So, too, another text was vividly brought to my attention, and I wondered how it was that our Lord in sending forth His disciples to preach, charged them that they should not greet anyone

along the way. I wondered why it was the Lord thus charged the disciples. What harm could there be in pausing sufficiently long to exchange the common courtesy? Surely there would be no harm, but I did not understand the reason. There must surely be a reason, for our Lord did nothing foolishly; there must have been some object in His having given that charge, but not until, from a Jerusalem sheik I got the facts, did I understand the full depth of meaning behind that sentence. It is a custom in the Orient, even to this day, for two people, who are acquainted, when meeting, to take each other by the hand, and take a hearty grasp, and begin to ply each other with questions concerning each other's welfare, their health, business interests, etc., and with each question and with each answer, they bumped their heads together, and the degree of interest they wanted to manifest in having asked that question must be demonstrated by the amount of force put behind that bump. It would be an indication of not having very much concern in the health and welfare of the other if one bumped lightly. And so, in order to impress the other that they were really concerned in asking the question, they put enough force in their bumps to carry the thought home. And then after they had exhausted their questions about each other individually, the questioning must be extended to the members of the family, and then to the relations, and by the time the greeting had terminated, there was often a headache produced which lasted three or four hours, and it consumed considerable time. Our Lord knew that the disciples would do justice to the occasion, they would not shirk in this matter, and their heads would come together with such force that naturally they would be rendered unfit for the service for which they were dispatched. He charged them not to greet anyone by the way -- not to pause to have this interchange of questions. It is just as proper there today for two persons to pass, not pausing to greet in this way, as for two of the business men of this town to pass without stopping to shake hands; no discourtesy would be shown whatever; therefore it would be perfectly proper for them not to stop to exchange such greetings. But if they commenced it, they must go through with it. We would not understand the reason and the depth of meaning back of that statement, if we were not familiar with the customs, or had some facts outside of the Scriptures.

So it is, I think, with this text, "The righteous shall flourish like the palm tree." That text was given to me some years ago as a subject for a testimony meeting. I hardly remember how I managed to get through with that service; I know that I did not do justice to the occasion. So I determined then and there that if that subject were ever mine again, I would familiarize myself sufficiently with the character of the palm tree so that I could do better. This led me to investigate the palm tree and it took years for me to get well enough acquainted with it so I could feel that I had something to offer on the text.

Now, why did God say, "The righteous shall flourish like the palm tree?" Why did He not say, like the oak tree? Is it not a grander, more majestic, more vigorous, a hardier and a more beautiful tree than the palm tree? Would not the wide-spreading elm have made a much better illustration of the way in which the righteous shall flourish? Or why did He not select the beach, or the maple, or any of the trees of the forest? Why did He select the palm? There must be some reason there, and it devolves upon us to ascertain for what reason the palm tree was selected. What is there about the palm tree that would command admiration, or draw forth our appreciation? It is apparently the most insignificant of all the trees. You have seen a telegraph pole before there were any wires on it. If we would fasten a little bunch of green at the top, we would have a picture of a palm tree. You have all seen pictures of palm trees. The casual observer would hardly stand and admire the palm tree for its beauty. It is a singular tree. It is

different from all other trees, and yet that very characteristic is doubtless one of the reasons why our Lord selected that tree as an illustration of the righteous.

We are said to be a peculiar people. Is not the palm tree peculiar? It stands out distinct from all other trees. It has a peculiar characteristic of its own. So we see, to begin with, there is something about the palm tree that would fit the text -- its peculiarity. Just as one passing the palm tree would not consider it much of a tree, nothing to command his special regard, just so it is with the righteous, the ordinary, casual observer, as he passes by sees nothing in the character of the righteous that appeals to him or her as worthy of commendation, of approval, or respect. It is written of the grandest character the world has ever known, our Lord Jesus Christ, that they hid as it were their faces from Him. He had no beauty in their eyes that they should admire Him; and if they would reject Jesus, the very exemplification of righteousness, much more would they reject any of His followers. But, just as the palm tree has its peculiarities, and is distinct from all other trees, different from each and all, just so it with the righteous; and we all know as we come in contact with one another that there is a difference; they are not like other people; there is a distinctiveness there; and something that we can appreciate, and that we can admire -- a particular love, something to command our respect and admiration, and every other good thing.

The palm tree, too, has a singleness of purpose. It grows straight; it does not grow to the right or to the left, this way or that way, but with singleness of purpose it grows straight, heavenward; so the righteous should be straightforward, with heavenly aspirations, ever striving and seeking for that which is above, setting their affections on that which pertains to the higher relations instead of those things which are beneath.

We read of men being crooked; we speak of them as being crooks sometimes, but it should not be so with the righteous; they should have integrity, they should be reliable, straight-forward, honest, upright in the sight of men and always looking forward and hastening to something higher, something grander. "The righteous shall flourish like the palm tree."

The palm tree rises above its fellows; it towers above other trees. You have all seen pictures of the palm; it is always the highest object in the picture; so it should be with the righteous; they should rise above the common, they should have proper dignity ever aspiring to that which is greater, lovelier, more exalting; and like the palm tree lift themselves high above the ordinary, high in the sight of God their Creator. "The righteous shall flourish like the palm tree."

Again, the palm tree is always green; it is an evergreen tree. Does not that set forth the characteristics of the righteous? That would not fit the oak tree, would it? By no means; the oak tree has at least a sense of being dead six months in the year, and it would not do for the righteous to appear to be dead part of the time, but they should be alive all the time. It is said that the oak tree grows for three hundred years, or thereabouts; then it stands for a period of about three hundred years, degenerates, and passes away. But not so with the palm. It has no period in which it reaches a condition of standstill, it is not content with reaching such a condition, but it is always aspiring to reach higher and higher, growing until it begins to go down. So with thee righteous; they should not be content with any position to which they may attain in the righteous, heavenly, upward, course, but ever seeking to grow higher and higher in the sight of God and in

the sight of one another --- setting their affections on things above, reaching ever onward and upward to a loftier attainment. "The righteous shall flourish like the palm tree."

The palm tree has another characteristic; it casts decidedly the least shadow, and thus does not interfere with the growth of its neighbors; it does not cast any reflection upon any who are seeking to develop, seeking to live, seeking to rise. So too, with the righteous; they should not cast any reflection upon anyone who is making any progress whatsoever. It is written of our Lord Jesus Christ, "A bruised reed shall He not break, the smoking flax shall He not quench." He cast no damper on anyone else who was making progress, although He made more progress than anyone else. "The righteous shall flourish like the palm tree."

The palm tree does nothing to hinder the sunlight from coming down or the rain from descending upon others that are seeking to prosper. So it should be with those who are righteously inclined. They should, like the palm tree, do everything possible to let in the sunlight of God's Word, to let down the rain of truth, that others might strive and be benefited by the blessings, and not seek to cast a damper, or any reflection, on others that would retract or retard them in their spiritual development and growth towards this lofty, heavenward attainment. "The righteous shall flourish like the palm tree."

We see, more and more, why the Lord selected the palm tree.

Again the palm tree has another peculiarity; it is the softest at the heart of all the trees. So too, it should be with us; we should not be hard-hearted; we should be sympathetic, compassionate, tender, solicitous of the interests of others. Like the palm tree, though, we may have a rough exterior, yet we should have a gentle, kind, loving heart toward all men, doing with our might what our hands find to do to please one another, and to please the Heavenly Father. "The righteous shall flourish like the palm tree."

Again, the palm tree has, in proportion to the size of the tree, the fewest and the smallest roots. The roots of the palm tree resemble very much a beet, or a carrot, or a pointed stick stuck in the ground with little rootlets running off from the main tap. It has the least hold upon the earth. Is not that the characteristic the righteous should possess? -- not being interested in getting hold of earthly possessions, but have just as little of earthly possessions as is possible in order to get along. As the palm tree's vitality, all the strength that it gets out of the earth, is used for its lofty attainments, thus rising ever onward and upward, so it should be with those who are righteously disposed; having comparatively little concern about earthly things, earthly possessions, earthly gains, all the strength they derive from the world in which they are -- we are in the world but not of it -- should be used toward this upward growing, this upward lifting, rising higher and higher in the sight of God and man. "The righteous shall flourish like the palm tree."

Furthermore, the palm tree will not be easily repressed. It is said that if someone will take a large stone slab, or some hard substance and place it over the spot where a palm tree is planted and endeavoring to grow, it would not deter the palm from its onward course, but it would come up right against that slab, go out to the edge of it and up again. You cannot make it grow in any other direction; it is bound to rise upward, bound to grow heavenward, bound to tower above. So it should be with us. We should not be easily discouraged, whatever the besetment may be,

whatever difficulty we may have, and whatever obstacles we have, these should not have the effect of dampening our ardor, or destroying the life we possess, or impairing our progress and growth and spiritual development to any appreciable extent. In spite of all these obstructions and inducements to turn aside, to press ever onward and upward in this straight and narrow way that leads to our heavenly home above, to be in God's favor as His children, not as servants, but as His sons possessing one of the mansions that our Lord declared He would go to prepare, although here are already mansions in the bright realm above. "The righteous shall flourish like the palm tree."

On the Mara Posa trail in California there is a place where a settler built a cabin years ago over a spot where a palm tree sought to establish itself. What did the palm tree do? Did it give up because of the obstacle placed there? Not so. It grew and kept on growing until it came up through the floor and went out through the ceiling, and on through the roof. The cabin stands there today, so far as I know, and also the palm tree rising above eighteen feet above it, and near the middle of the dilapidated hut. Nothing in the way of obstruction or burden placed upon it discouraged or retarded its growth. So it should be with us. Having put our hands to the plow, determined to go on, nothing should daunt us. Let the conditions be what they may be, if we cannot go around them, go through them; if we cannot go through them, climb over them, go under them, or pass them somehow, some way, and keep on in the course marked out as our pathway towards the goal to which we are all striving, the heavenly attainment. "The righteous shall flourish like the palm tree."

You will remember that we are speaking particularly of the date palm. All commentators and writers of the encyclopedias tell us the date palm is always referred to in Scripture connection. It is a fruit-bearing tree, and surely our heavenly Father would have used nothing here but a tree that bears fruit.

The palm tree does not bear fruit for itself. Neither should we bear fruit simply for ourselves. What do we mean by the fruit? Paul tells us the fruits of the spirit are love, joy, peace, brotherly-kindness, temperance, and all those other kindred qualities, and these we should have in abundance that the ordinary passer-by might be profited, benefited, blessed and helped in his onward course along the straight and narrow path that leads to heaven. "The righteous shall flourish like the palm tree."

The older the palm tree, the sweeter the fruit. Should not that be true of the Christian? The longer they are established, the longer they are in the way, the sweeter should be the fruit. Naturally so. If we are established for a considerable time, we ought to expect sweeter fruit and in greater abundance, just as with the palm tree.

One can go to the palm tree early and late and get fruit. It has a prolonged fruit bearing period. One can go there, so to speak, in season and out of season, all the time, and get fruit. Its fruit bearing period is not limited to a short space of time. So it should be with those who are righteously inclined. One should be able to go there any time, early and late, in season and out of season, and get an abundance of fruit, and the longer one is established, the longer he has been in this heavenly way the sweeter should be the fruit. "The righteous shall flourish like the palm tree."

Another peculiarity: it furnishes all that man needs. Of the trunk, man can build his home and manufacture his furniture, and other useful utensils; out of the strands of the leaves he can make baskets, etc. And out of the fibers of the leaves can be made a substantial cloth closely resembling satin, and the juice exuding from them is said to be very nutritious; and thus the palm tree furnishes the necessaries of life. This would seem to teach that we should be content with such things as we have. We may not have satins and silks and luxuries, but we do have all things needful, and with these we should be content

"The righteous shall flourish like the palm tree."

The palm tree generally grows along the edges of the desert. I could not verify this, but I had to take it from writings that, when the dust blows across the desert in sweeping clouds of sand storms, the dust and sand usually accumulate on the limbs and branches of trees; but it is said that one can go up to a palm tree and find comparatively little of this accumulation. What does this teach us? It keeps itself unspotted from the filth of the earth. So it should be with us. We should have purity, and not be contaminated by the evil influences, and by the various winds of doctrines that are wafted about by every breeze, but should keep ourselves unspotted, pure, clean and white, and thus be free from this contaminating influence. "The righteous shall flourish like the palm tree."

Again, where the palm tree grows another thing has its existence, and this thing is called a tree-killer. It is a poisonous vine, something like our poison ivy. If it gets hold of a tree, it grows close to that tree, hugging the bark closely, and after awhile it will entirely surround the tree, something after the style of a grape vine we have seen completely enveloping the tree it grows upon. It clings very closely and shuts out the sunlight, and the tree eventually dies; but the poison vine, the tree-killer, remains and stands there in the shape the tree originally was, the tree having formed it, and the tree inside is dead; the vine has killed it. There is only one tree known that can successfully resist the tree-killer, and that is the palm tree. Now, the righteous should be like the palm tree in that respect, surely. Whatever burden may be placed upon them, whatever poisonous besetment, or poisonous influence, might be in the way, anything that would seek to take the life, in spite of all this, we should keep on in our course. "The righteous shall flourish like the palm tree."

Now, we see there was a reason in this statement. The Heavenly Father understood the matter when He said, the righteous should be like the palm tree, should emulate its character; and so let us, dear friends, be of that disposition, of that character, and think of the palm tree with appreciation and admiration.

Now, how about the wicked? Oh, that is a different proposition. I did not have the opportunity to study the bay tree, that I had to study the palm tree, having seen and studied perhaps seventy-five during my recent trip to the Pacific coast; but I did learn something about it. I had two opportunities to study the palm tree, both in California and in Mexico. The two best bay trees I have seen are at the gate-way to the Stanford University at Palo Alto, California, although I saw a single specimens in the State of Oregon.



One seeing a green bay tree would not have the same feeling as when seeing a palm tree. I venture the assertion that almost anyone looking upon a green bay tree for the first time would be pretty apt to say, I would like to have that tree in my front yard -- Oh, what a handsome tree! With its wide-spreading branches, almost touching the ground at its extremity, some of them perhaps touching the ground, with its wealth of foliage, it would not permit the sun to come down through it. How nice it would be to have a hammock stretched under there? But the green bay tree is the opposite of the palm tree. It is a low tree. Compared with the palm tree, it is a mean tree, a tree to be looked down on, yet there is that profession, that spreading of branches and leaves, that would command our respect and our admiration, and the general passer-by, the ordinary individual, the average worldly person, would regard it as being a most beautiful thing. They would want to be in possession of one of them. But if we would go under a green bay tree and look up into it, our respect would be lessened considerably, for we would find that the limbs are naked, uneven, gnarly, crooked, twisted, and devoid of foliage. The foliage is all on the outside, comparatively speaking. All the profession is where it can be seen, making a grand display to the ordinary passer-by -- putting as it were, the big apples on top, where they can be seen, making all the show possible with the possessions it has. Is not that the characteristic of the wicked? The wicked spreading like the green bay tree. They make as much show as possible with what they have.

The green bay tree, instead of having a soft heart, has an exceedingly hard heart. It is like the wicked, -- indifferent, stony-hearted, lacking sympathy. Not like the palm tree, not like the righteous, having consideration, sympathy, and the welfare of others at heart, having love, and so forth, for one another, but having the characteristics of selfishness in its every line.

The green bay tree does not bear fruit, but it makes a pretense at bearing fruit. If we approach a green bay tree, we would find little round balls on it, not regular, but irregular, about the size of an olive, not smooth, but rough. At first thought, we would say, that is a fruit-bearing tree; it looks like it; it makes that bluff, so to speak, but if we take one of those little balls and crack it open, we will find only a seed. What does this mean? The green bay tree is not interested in bearing fruit for somebody else. What looked like fruit was in reality a seed, with the design or intent of spreading its kind, advancing its own family interests -- as Brother Russell has often said: "Me and my wife, my son John and his wife; us four and no more." "The wicked spreading himself like a green bay tree." We see the reason for using that statement in regard to the wicked. And it does not appear on the surface. If we want to learn anything of God's Word, we must remember the rule, "Seek and ye shall find, knock and it shall be opened unto you." Those things that are worth anything are not found on the surface. You remember it is written of our Lord, He spoke in parables and dark sayings, in order that His meaning might not appear on the surface, but be necessary to dig down deep. If we want anything of value, such as gold, silver, or precious stones, we will not find them on the surface; we will have to dig. It requires sacrifice, it requires effort, in order to obtain, and so it is with the precious things in God's Word. If we want anything, we must dig for it. We can seek and find, knock and it shall be opened. So we do not want to do surface reading and say, "Yes, I know all about it." Surely if we would read hastily that sentence, "The righteous shall flourish like the palm tree," we would be pretty apt to pass on to the next sentence without understanding very much about it, because we did not go outside the Scriptures and get the facts upon which the statement was based.

Under the two bay trees standing at the entrance of the Palo Alto grounds, previously referred to, there was not a blade of grass or a green shrub of any kind. It was just as bare as an ash-pile. Nothing could grow there. The rain could not come down there, and it was as dry as tinder. Neither could the sunshine come through. So that shows the characteristic of the wicked. They would turn aside the sunlight of God's Word, turn aside the rain of truth, do everything they can to hinder and retard the growth of others that are striving to go on in the right way. "The wicked spreading like a green bay tree." How true!

As to the roots of the green bay tree, it seemed like the ground could not hold them all. They would come up out of the ground, then down again, and up again, and I could trace them for forty and fifty feet from the trunk of the tree -- interested in getting worldly possessions, and interested in getting a secure hold upon the earth. While making as big a spread above as possible, in an underhand way reaching out in every conceivable direction to get more. This is mine, that is mine, that belongs to me, I lay claim to that, etc. -- interested in getting hold of earthly possessions, earthly property, real estate, etc. Get all you can; keep all you get. The way some of these roots passed along suggested to my mind the thought that they are not content with what they already have, but are looking for something more.

A gentleman, who understood the nature of the tree, called my attention to the nature of the branches of the trees. He said, just break off one of those branches, and I reached up -- and I did not have far to reach -- and gave a branch a snap, thinking of course it would drop off like branches usually do. But it did not break off. It was about the size of a lead-pencil. I got a firmer grip on it, pulled, then took hold with both hands and pulled, and pulled until I think I shook half of the tree, but I could not break it off. Then I took that branch and tied it into a knot, and then tied it into another knot and drew it tight, then took my knife and cut it off. If you get any of the possessions of the wicked, you will have to work for them. You may get them, but you will have to work for them. They hang on to what they have -- that is mine, it belongs to me. It is nothing like the palm tree, handing out its fruit in bunches, big bunches of it -- help yourself, take as much as you want, or if you want to pick it off one at a time like grapes or bananas, all right; take it that way. But with the wicked, no -- hold on, hang on, says the green bay tree; I have nothing to give; it is mine; it belongs to me; keep all you get, and see if you cannot get some more. "The wicked spreading like a green bay tree."

In the middle of the burned district in San Francisco, there is a green bay tree about twenty inches in diameter, I should judge, that was burned literally to a charred trunk; the bark was burned off it; and it put forth leaves and grew again. It is a very hard thing to destroy. So with selfishness: it takes a great deal to crush out the life of selfishness. "The wicked spreading like a green bay tree" -- they hang on to that precious life they have.

And the same gentleman I spoke of a while ago who told me to break off a branch, said, after I had done so, Now just crush those leaves in your hands. I stripped off some of those that were on the little twig and rubbed them in my hands, and was wondering what would happen, but nothing happened, and I looked up at him somewhat in wonder, and he said, Just smell of your hands. That settled it; it was a sensation very much like that which comes from inhaling very strong ammonia. It was charged with the most disagreeable odor, and in less than five seconds I had a very severe headache. And I suppose I have smelled of those leaves a score or more of times

during my trip west, and in every instance I had a headache that lasted from at least five to ten minutes. That carried home to mind the thought, don't rub up against the wicked; don't produce any friction there, don't stroke them the wrong way. If you do, you will wish you had not; you will want to get away from there. "The wicked spreading like a green bay tree." It is all right enough to go off at a distance and have a certain amount of admiration and regard for the thing but do not get intimately acquainted with it, to the extent of rubbing up against it very hard, or you will produce a condition that you will want to get away from. We all know how that is.

Now we have on the one hand the characteristics of the bay tree, -- the wicked spreading like the green bay tree, -- and on the other hand we have the palm tree, a tree differing very materially from the green bay tree in almost every respect, if not quite so, and yet in its simplicity to be looked up to by us at least with appreciation, with admiration. And I appreciate very much the effort of a little sister who sent me a little drawing which she called a beautiful palm tree. I do not know how old she was, but she was quite young. It represented her endeavor to set forth her appreciation of the palm tree from what I had said about it, and from what she had learned of its characteristics. "The righteous shall flourish like the palm tree."

Now, dear friends, it is for us to determine which of these two trees we wish to emulate. Shall we follow those characteristics that pertain to the green bay tree, or those that pertain to the palm tree? It is up to us, in the language of the day, and I feel sure that all of us here will want to go in that straight, narrow, and heavenward way, rising above the things of the earth, towering above that which is ordinary, and ever striving onward and upward, seeking to attain to the heavenly aspirations.

Brother Van Amburgh: I desire now to give a little testimony, as I shall leave the convention tomorrow, and this will be my last opportunity to do so. I have had some very delightful experiences during this convention so far, and were I able to do so, should certainly stay the balance of the time. But it is necessary for us to choose between duty and pleasure sometimes, and this choice is necessary for me to make, and it will be necessary for me to leave tomorrow morning early, so I will probably not have the opportunity of meeting any, or at least not many, of you in the morning. At the close of this meeting, I will be at the door and will be glad to shake hands with just as many as care to shake hands with me. I am glad to have had the privilege of meeting with you all, and becoming personally acquainted with so many of you, and I have learned to love you more because I have become better acquainted with you. As I see the spirit of the Lord manifested in your hearts, and as expressed in the handshakes, it inspires me to feel that I want to be more like the Lord, and want to manifest His spirit more and more. I trust this spirit has been increasing; I feel it has been.

We are expecting Bro. A. E. Williamson, who will be chairman of the second part of the Convention, to arrive tonight, so I will bid you all good-bye.

This closed the first part of the Convention, of which Bro. Van Amburgh was chairman. Bro. Williamson, chairman of the second part of the Convention, arrived at Norfolk, Thursday morning, and was warmly greeted by all the dear friends.

## THURSDAY, OCTOBER 3.

This day was given over to informal social interchanges; and the friends chose their own method of spending the day; some went to the Jamestown Exposition; some to view the ocean, and many visited the Army and Navy Yards, and went through one of the large battleships. Many lessons were drawn from viewing these great engines of destruction. We were all glad that we were "Soldiers of the Cross," and rejoiced in our hearts to know that before long all those guns and battle-ships would be turned into pruning hooks, etc.

At 4:30 Bro. Russell left the Convention for the Bible House. About 40 went to the depot to see him off. As the train was pulling out, we all joined in singing "God Be With You," and waved our handkerchiefs, as a parting salute of LOVE. It was a very impressive scene; and as we saw "That Servant" disappearing in the distance, our own hearts rejoiced in realizing that we were having a part with him in this great harvest work.

Brother A. E. Williamson, Chairman of Second Part of Convention.

### 7:30 P.M. -- Discourse

*by Brother Frank Draper,*  
on the subject:

**"The Spirit the Water and the Blood, these Three agree as One."**

BRO. DRAPER spoke, in substance, as follows:

The subject for our study is suggested in the 8th verse of the 5th chapter of John's first Epistle: "And there are three that bear witness in earth, the spirit and the water and the blood: and these three agree in one."



Brother Frank Draper.

If we did not notice particularly to whom these words apply, we might wonder why they are made in the way they are found in this verse. We might wonder why the blood is not stated first, because all Christians recognize that the foundation of the Christian religion, so to speak, is the death and resurrection of our dear Redeemer, who was delivered for our offenses and raised again for our justification, and suggested in the third verse of the 15th chapter of First Corinthians, "For I delivered unto you first of all that which I also received, how Christ Jesus died for our sins according to the Scriptures, and was raised again the third day according to the Scriptures." But when noticing that these three propositions, the spirit and the water and the blood are made with reference to our dear Redeemer, it is all plain. If they had been made with reference to those who become His disciples, His followers, it is very probable -- indeed we feel certain -- that the blood would appear first, as in some other texts. When reading two or three of the preceding verses, we will see that these verses apply to our Lord Jesus. Beginning with the fifth and reading to the seventh,

which omit, as it is not in the original Scriptures, but even if it were, it is not pertinent to our subject, we read: "Who is he that overcometh the world, but he that believeth that Jesus is the Son of God? That is He that came by water and blood, even Jesus Christ; not by water only, but by water and blood. And it is the Spirit that beareth witness, because the Spirit is truth, and there are three that bear witness in earth, the Spirit and the water and the blood: and these three agree in one." As the Diaglott renders it, "These three are for one." And who is he? Why, the Lord Jesus Christ. And, dear friends, all that is suggested in these verses constituting our text was fulfilled during the brief period of three and one-half years, beginning when our Lord was immersed at Jordan, and ending when on the cross He exclaimed, "It is finished," and when the blood and the water flowed from His side. The thought of the text then is, the Spirit, the water and the blood bear testimony to the Messiah, or Jesus, whom God sent into the world to become its Savior, its Redeemer. And then, of course, many other texts show that all who are in their graves shall hear His voice and come out of the death condition, when hell will deliver up the dead in it. Our dear Redeemer during the thirty years of His earthly life prior to His baptism by John in Jordan was perfect in every respect. He was without spot or blemish. But at the same time our text did not apply to Him during that period, but during the period when He was baptized in Jordan, and terminating when He expired on the cross.

In the first verse of the 61st chapter of Isaiah we find this prophecy recorded of Jesus: "The Spirit of the Lord God is upon me; because the Lord has anointed me to preach good tidings unto the meek." Our dear Redeemer did not preach glad tidings prior to His baptism. And so far as we can learn from the Scriptures, He did not have the power that He possessed during the three and one-half years of His ministry. As a perfect human being, no doubt He possessed very great power. We do not know what powers a perfect human being possesses. We do not know what powers Adam possessed as a perfect human being before the fall; we do not know what the powers of our dear Redeemer were before He was baptized by John in Jordan, but He received a special gift from Jehovah, and that is called in the Scriptures the holy Spirit, God's holy power, God's holy influence, which authorized and empowered Him to work great things and teach beautiful lessons that He never would have been able to accomplish without that power of the holy Spirit. You will recollect at least that He applied the prophecy quoted from Isaiah 61 a few moments ago, to Himself, in the 4th chapter of Luke: "The Spirit of the Lord is upon me because He hath anointed me to preach glad tidings to the meek." And, in the 10th chapter of Acts we find it stated by the Apostle Peter that God anointed Jesus with the holy Spirit and with power. While that is true, it was not omnipotent power, it was not all power, and it was a limited power, even though it was very great, by which He accomplished such wonderful things; but it was not equal to the power which came into His possession when He was resurrected. He said to His disciples after the resurrection: "All power in heaven and earth is given to me." We see that He did not possess all power.

What about the water? Notice that the first proposition is the Spirit, and the second is the water, and the third is the blood. And the sixth verse says He came not by water only, but by water and blood; He came by those two things, and then the Spirit bore witness, you see, to these two things, so to speak. And when was that witness born? It is shown in two or three of the Gospels, but we had in mind more particularly the third chapter of Matthew, that it was when He was baptized in Jordan by John. John saw the holy Spirit descending from the heaven in the form of a dove on Jesus and heard the voice, "This is my beloved Son, in whom I am well pleased, hear ye

Him." And then the water began to bear witness, to give testimony to the messiahship of Jesus, and three and one half years later the blood gave similar witness or testimony. Notice the spirit is first, and then the water, and then the blood.

But you might be disposed to say, if the water came second why is it intimated in the text quoted that it was after Jesus was baptized in water that the Spirit descended upon Him, that God bestowed on Him the gift of the Holy Spirit without measure? Why was He endued with power from on high there? Why does it seem to be stated in that way, if the water is second? Was He not baptized in water apparently before He received the holy Spirit? Wasn't it because He was obedient in the performance of that rite, saying to John, "It thus becometh us to fulfill all righteousness," that He was baptized with the holy Spirit and with power? Dear friends, I think it will appear very clear to your minds when we suggest to you that the word "water" in the text does not refer to literal, ordinary water, but to an entirely different kind, represented, illustrated, symbolized, by literal, natural, ordinary, water. It is called in the Scriptures, the water of the Word. Now after our dear Redeemer was baptized by the holy Spirit and endued with special power from on high, He began to speak as man had never spoken before. He spoke wonderful words of life. He continued to speak those wonderful words of life for three and one-half years, and you know the effect those wonderful words of life had on the minds and lives of those who became His disciples. He said to them, Now ye are clean through the word which I have spoken unto you; ye have been washed and made clean through the water that I have given to you.

Now, dear friends, we will read a little about this water from the 4th chapter of John: "Then saith the woman of Samaria unto Him, how is it that thou, being a Jew, asketh drink of me, which am a woman of Samaria? Jesus answered and said unto her, if thou knewest the gift of God, and who it is that sayeth to thee, give me to drink; thou would have asked of Him and He would have given unto thee living water. The woman sayeth unto Him, Sir, thou hast nothing to draw with and the well is deep: from whence then hast thou that living water? Art thou greater than our father Jacob, which gave us the well and drank thereof himself, and his children and his cattle? Jesus answered and said unto her, whosoever shall drink of this water shall thirst again, but whosoever shall drink of the water that I shall give Him shall never thirst; but the water that I shall give him shall be in him a well of water springing up into everlasting life."

Then again in the 7th chapter of John, beginning with the 37th verse, we read: "In the last day, that great day of the feast, Jesus stood and cried, saying, if any man thirst, let him come unto me and drink. He that believeth on me, as the Scriptures hath said, out of his belly shall flow rivers of living water. But this He spake of the Spirit, which they believed on Him should receive, for the holy Spirit was not yet given; because that Jesus was not yet glorified."

Please notice the difference, dear friends; because Jesus received the Spirit without measure this living water flowed from His lips for three and a half years and gave life in a reckoned sense to those who became His disciples, and He washed them, cleansed them, to a considerable extent from their defilement. When the holy spirit was bestowed upon the disciples in the upper room in Jerusalem, then this text began to apply to them, Out of their belly (out of their mouths) shall flow living water (the water of truth, refreshing, strengthening, as well as cleansing, those who became the Lord's footstep followers for more than eighteen centuries past).

You will perhaps remember this text in the 12th chapter of Isaiah: "Therefore with joy shall ye draw water out of the wells of salvation." During the Gospel Age, beginning at Jesus' first advent, more particularly at Pentecost as we are considering the matter now, and ending shortly, the Lord's people have been drawing water from the well of salvation. There has been no river flowing for them, but they have been using the well. You have been, dear friends, wells from which other dear ones have drawn water; and I trust by God's grace, we have been able to give you a little water of the precious Word tonight. I trust you are giving out this water to the fellow members of the Body of Christ daily. But by and by these wells will come together, so to speak, and they will constitute the source or fountain of the great river of life that will flow to bless, and cleanse, and give life, to all the obedient of the human race.

It is mentioned in the 22nd chapter of Revelation as the river of life that John in a vision saw flowing underneath the throne of God and the Lamb, and then whosoever will may come and drink of that water of life and live forever. That is when the Spirit and the Bride will say come. Now the Spirit is saying come, drawing the members of the prospective Bride class to Jesus that they may drink of this water of life and become wells themselves. You remember Jesus said, No man cometh unto me except the Father draw him. But when the Church is completed and glorified, constituting the Bride, then the Spirit and the Bride will say come, and whosoever will may come and drink of the water of life freely.

We will read of this river of life from Ezekiel the 47th chapter, beginning at the first verse:

1. "Afterward he brought me again unto the door of the house; and, behold, waters issued out from under the threshold from the house eastward: for the forefront of the house stood toward the east, and the waters came down from under from the right side of the house, at the south side of the altar.
2. Then brought he me out of the way of the gate northward, and led about the way without unto the outer gate by the way that looketh eastward; and, behold, there ran out waters on the right side.
3. And when the man that had the line in his hand went forth eastward, he measured a thousand cubits, and he brought me through the waters; the waters were to the ankles.
4. And he measured a thousand, and brought me through the waters; the waters were to the knees. Again he measured a thousand, and brought me through; the waters were to the loins.
5. Afterward he measured a thousand; and it was a river that I could not pass over: for the waters were risen, waters to swim in, a river that could not be passed over.
6. And he said unto me, Son of man, has thou seen this? Then he brought me, and caused me to return to the brink of the river.

You have all read about that in the book of Revelation. There was a river of water of life flowing from underneath the throne of God. That is at the time of the parable of the sheep and the goats, when it is said the Son of man shall come to all His glory and all the holy angels or messengers,

and the saints, with Him, then He will sit on the throne of His glory, and all nations shall be assembled, and then, thank God, that river of the water of life will flow from underneath the throne of God and the proclamation will go forth, "Whosoever will may come!"

I refer you now to the 7th and 8th verses:

"Now when I had returned, behold, at the bank of the river were very many trees on the one side and on the other.

"Then said he unto me, These waters issue out toward the east country, and go down into the desert, and go into the sea: which being brought forth into the sea, the waters shall be healed."

It is the same idea of which we read in the Book of Revelation: "The sea gave up the dead in it" - the lawless, restless, and anarchistic classes of humanity. We are very rapidly approaching that sea condition now. There will be no saints in it, but only people of the world. When the time of trouble is over, that sea class, many of its members having survived the awful storm, will stand before the great white throne to be judged. Then, thank God, there will be no more sea, there will be no more anarchy, no more tribulation on earth, for it will have forever passed away, and there will be a new heaven, a new ruling power, and a new earth.

Then I will read the 12th verse of the 47th chapter of Ezekiel also: "And by the river upon the bank thereof, on this side and on that side, shall grow all trees for meat, whose leaf shall not fade, neither shall the fruit thereof be consumed; it shall bring forth new fruit according to his months, because their waters they issued out of the sanctuary: and the fruit thereof shall be for meat, and the leaf thereof for medicine"

That is when the leaves of the trees shall be for the healing of the nations. When that river begins to flow, the Scriptures seem plainly to indicate that it will be only ankle deep and will cover the earth early in the Millennial age. Later it will be knee deep, a little later it will be loin deep, and a little later, at the end of the Millennial age, so deep that people can swim in it; it will be ocean deep; it will be worldwide; all will know Jehovah from the least to the greatest, and then nobody will have the least vestige of an excuse for not coming into the knowledge of the Lord.

And this then evidently is the water mentioned in our text There are three that bear witness, the Spirit and the water and the blood. And these three agree in one -- they are united in testifying that Jesus, the Messiah, is the Savior of mankind.

Now a few words about the blood before we take up another feature of the subject. I am sure that we can all quite easily discern what is meant by these three propositions. How plainly it is taught in the Scriptures that it is only through the shedding of blood of our dear Redeemer that the remission of sins can be obtained, for "Without the shedding of blood, there is no remission of sins." You know that under the law for eighteen centuries thousands of birds and animals were sacrificed, but the Apostle tells us in the 10th chapter of Hebrews, the blood of those sacrifices did not cancel any one's sins. He explains there that the very fact they were offered year after year for centuries was positive proof they did not cancel anybody's sins. If they had cancelled sins, one offering would have been sufficient, just as the one great offering Jesus made at



Calvary was sufficient to cancel the sin of the world, as expressed in John's statement: "Behold the Lamb of God that taketh away the sin of the world."

Those Scriptures pointed forward and typified that great, grand, complete, all sufficient sacrifice, and then they provided a typical justification, or covering, for the Jewish people. God showed favor to them that He did not show to the Gentiles, who in that period were without God and without hope in the world. And then also, and I think chiefly, they emphasized the fact so plainly taught throughout the blessed Book that, without the shedding of blood, no fallen human being's sins could be remitted.

So then we see that the three statements, the Spirit and the water and the blood, all apply to our dear Redeemer, and now we want to consider for a while how they apply to those who are footstep followers, to those who will be made joint-heirs with Him in the kingdom, to those who will get eternal life on any plane. All who will get eternal life on any plane must have the blood. We are going to reverse the order now; they must have the blood, they must have the water, and they must have God's holy Spirit. I am not intimating that all who will get life on earth, the kind of life Adam possessed for a little while before he sinned, perfect human life, will have the spirit in the sense the members of the Church have it now, in the sense our dear Master, the great head of the Church, possessed it there, but God at that time will pour His spirit out on all flesh, and all flesh will see the glory of God together, and it will be necessary for them to be in harmony with Jehovah's righteous laws. It will be necessary for them to fully consecrate their lives to Him, to submit their wills to God, to give their hearts to God, in order to obtain eternal life. Those who become the Lord's footstep followers now are baptized into His death, and they become heirs of God and joint-heirs with Jesus in the kingdom, and they must fully surrender their wills to the divine will. The surrender of the human will to the divine will in this age means the baptism of the will unto death, as Paul expresses it in the 7th chapter of Romans: "Know ye not that, so many of us as were baptized into Jesus Christ were baptized into His death."

He who presents his body to God in this Gospel age, his reasonable service, is baptized into Jesus' death, while those who offer themselves during the Millennial age will not be baptized into His death; they will have God's holy Spirit, but they will not be forgotten to the Spiritual nature; they will not be new creatures in Christ Jesus.

Well then, dear friends, with respect to all who are now our Lord's disciples (for we wish to speak more particularly of that class at the present), they must have the blood, the water and the holy Spirit; and with respect to them, these three agree. Now this text formerly applied to our dear Redeemer, but by reversing the order of this proposition it can be applied to His followers as well.

In the 22nd verse of the 10th chapter of Hebrews, these words are written: "Having our hearts sprinkled from an evil conscience, and our bodies washed with pure water." Now here are two separate and distinct propositions -- our hearts sprinkled from an evil conscience, and our bodies washed with pure water. Having our hearts sprinkled from an evil conscience means that because we have accepted Jesus as our Savior, and believed with our hearts unto righteousness, God does not impute sin to us. In the 9th chapter of Hebrews Paul explains that the Jews under the law, for whom these typical sacrifices were offered, did not have their hearts sprinkled from a

consciousness of evil. Why? Was it because they were all dishonest and hypocritical, or insincere? No. Many of the Jews under the law were honest, sincere, Israelites indeed. They were in their hearts in harmony with the Lord, just as you and I are striving to be in harmony with Him in our hearts. But on account of certain motions in the flesh inherited from the fall, they were not able to come up to the standard; the standard of the law was a perfect standard and it was stipulated that whosoever kept the law should live. But whoever keeps the whole law and is guilty upon one point is guilty of all And you remember the 10th commandment: "Thou shalt not covet" -- thou shalt have no wrong desires, thou shalt not have the least bit of selfishness; the least bit of selfishness is beneath the standard of perfection, and the standard would be one hundred points, one hundred per cent. There was no Jew under the law who could come up to that standard. Perhaps some of the Jews kept the nine commandments very well, but the tenth was, "Ye shall not covet," and no fallen man could keep that, so no Jew under the law, except Jesus who was perfect, could keep the law. You remember that Jesus, made under the law and born of woman, was the perfect man Christ Jesus, and He kept the law; therefore was entitled to the life the law promised to those who kept it. But instead of keeping that life He sacrificed it to redeem the human race, and also to redeem the Jews from the curse of the law. Well, then, because the blood of bulls and goats did not cancel anybody's sins, the Jews under the law had all of their imperfections charged against them. Or, if you can imagine a Jew having only one imperfection, just having a little bit of covetousness, that would bring him under condemnation, because it would bring him under the standard; he had not reached the standard.

Now, how is it with those who accept Jesus? Are they better in their hearts than those honest Jews? No. Do they live better lives than Nathaniel, and those other Israelites indeed, lived? No. What is the difference, then? It is this: Those whose hearts are in harmony with the Lord, and who are living to the best of their ability, and by faith appropriating the merits of His death to themselves, their covetous dispositions which they have, and which they are striving to overcome, and the many weaknesses of their flesh, God does not charge against them. Why? Because they are acceptable in the Beloved; they are complete in Christ. This text in the 4th chapter of Romans applies to them: "Blessed are they whose iniquity is forgiven and whose sins are covered." It does not say, Blessed are they who have no unrighteousness. That would be a happy condition to be in. But blessed are those who continue to walk in the Master's foot-steps a little while longer, fighting the good fight of faith, being faithful unto death. That does not mean serving God perfectly. If that were the proposition, then you and I could not meet the conditions. But this is the proposition: To all who have accepted Jesus, and are endeavoring to walk in His footsteps, and have made a full consecration of their all to Him, being faithful unto death, He will give them the crown of life. Keep on believing, and do not let anyone swerve you from the narrow way you have entered. Those who are trusting in the merits of His death do not have their weaknesses and imperfections charged against them; they are free from a consciousness of evil; they are free from all iniquity. But if any child of God should say, "I have no sin," what would be his condition? John describes it: "If we walk in the light, as He is in the light, we have fellowship with one another, and the blood of Jesus Christ His Son cleanseth us from all sin." Mark you, it does not say cleansed (past tense) us from all sin." It is in the present tense -- cleanses us from all sin. But if we say we have no sin to be cleansed from, we deceive ourselves, and the truth is not in us.

Some in different parts of the world are deceiving themselves. They are not bad people, they are not hypocrites. Hypocrites are not self-deceived, for they probably know they are acting hypocritically, but these dear people are deceiving themselves, saying "we have no sin, We are free from all the defects of the fall." I trust we are not of that class. I trust we are of the class who intelligently use this petition, "Forgive us our trespasses as we forgive those who trespass against us." Every time we offer this petition we are confessing our sins, and our imperfections. Our brothers, and sisters, and neighbors, and enemies, trespass against us; our friends, and brothers and sisters, unintentionally, and frequently perhaps unconsciously, say sharp things, and giving what we might regard as unkind looks, etc., but we do not charge these against them. No, no, we know they are weak, and we gladly forgive them. We are on the lookout for opportunities to forgive without even being asked.

But you might be disposed to say, it is stated in the text you quoted that the blood cleanses us from all sin. Yes, but it is a reckoned cleansing, it is not an actual cleansing. If it were an actual cleansing it would not be called a covering, as it is in other texts. The proposition then is, that while we are out of harmony with evil and fully consecrated to the Lord, endeavoring to walk in our Master's footsteps, our shortcomings, our imperfections, are not charged against us.

So then this is the signification of the first proposition of the text we are considering -- having our hearts sprinkled from an evil conscience, or from a consciousness of evil. I fear that sometimes we do not lay sufficient stress upon it in this way: some of the dear brothers and sisters who are exceedingly humble-minded take the position that because they are so weak, and make so many mistakes, they are not acceptable to Jehovah. They say, there is my neighbor, Mr. and Mrs. So and So, they are better born, better bred, and have a better education than I have, and I do not wonder that the Lord accepts them and gives them a blessing in the race for the prize, but I am such an insignificant creature that I fear He will not accept me as a runner in the race. I think He has forgiven my sins; I think for Jesus' sake my past sins are all forgiven; He has removed them from me as far as the east is from the west, and I almost, if not quite, believe my present sins are covered; but I can hardly think He would accept me as a runner in the race for the great prize, or that He has accepted me. Now when brothers and sisters say to me: Brother Draper, we are insignificant, and amount to very little, I do not contradict them; I never would think of doing so, because I feel that it would be unscriptural. We are all insignificant; none of us amount to very much, dear friends, and were it a question of worth or merit on our part, the Lord never would have started us in the race. But this is the Bible way of stating it; the Lord has chosen the base things to confound the mighty, and the things that are not to bring naught the things that are, in order that no flesh should glory in His sight. And that is not all: as a rule those who are a little lower in the mental and physical, and sometimes even the moral, scale than others, are more humble-minded, and are, therefore, in a better attitude to accept the call to enter the race to joint-heirship with Jesus in the heavenly kingdom.

Now if we have accepted Jesus as our Savior; if we have believed with our hearts unto righteousness, and made confession with our mouths unto salvation, and have fully surrendered our wills to the divine will, and are saying, Lord, not my will but Thine be done, and loving the brethren, and loving even our enemies with the love of pity, entertaining no evil or bitter thoughts in our hearts against anybody, then we may be sure that our Heavenly Father has not only called us to run for the great prize, but that we are in the race. The very fact that we love the

brethren, the very fact that we take pleasure in associating with them, and in studying the precious, heavenly, spiritual truths of the Lord's Word, is proof that we have passed from death unto life. Now, if this is your blessed experience, if you hate sin and love righteousness, and have fully surrendered yourself to the Lord, and are this night saying, "Lord, here I am, do with me as seems good to you; I give myself to you; it is all I can do," and if you find in your hearts genuine love for the brethren, if you take pleasure in associating with them, and being with them to study the Lord's Word, etc., then you may be sure God has called you and given you a place in the race.

You did not call yourself; you did not say, I am going to enter the race for that great prize. I trust you have never had such a thought as that. I trust you felt about it as Jesus did, "I delight to do Thy will, O God." I wish I could serve as perfectly as He did; I want to perform my reasonable service; I know that is to present my body a living sacrifice to you, and, Father, here I do that; I will not take into consideration so much what you have in store for me; I know what you have in store for me will be a million times better than I deserve, or my poor, finite mind could comprehend, and so here, Father, I will perform my reasonable service: I will present my body a living sacrifice to you. That is the way you started in the race, my dear brother and my dear sister. The Apostle Paul did not say, "Brethren I beseech you to enter the race for the great prize." No, but perform your reasonable service, give yourself fully to the Lord, and the Lord is so pleased with those that do that, that He starts them in the race for the prize; He inspires heavenly hopes and ambitions in their hearts, and they begin to aspire heavenward, and to lay up treasure in heaven, seeking the things which are above where Christ sitteth on the right hand of God; their hearts are anchored within the vail, where Jesus, our forerunner, has entered. He never called Himself by saying, I will be a High Priest; I am going to get that honorable, that glorious position. No, no, He humbled Himself and became obedient to death, even the shameful death of the cross, wherefore, as a result, God highly exalted Him. His ambition was to please the Father. And what was the consequence with respect to Himself? Jehovah bestowed on Him the highest honor. Our dear Redeemer deserved it, but what surprises and astonishes me is, that He calls fallen and imperfect human beings to share His glory also. You did not call yourself to that honorable position, dear friends, but God called you, and now what remains for you to do is to run as patiently as possible the race set before you, looking unto Jesus, not looking unto yourself.

"Yes, but I have a great many weaknesses, a great many blemishes, and make many mistakes."

Are you in harmony with your weaknesses, and blemishes and mistakes? If it was something sharp you said, do you approve that?

"No, I hate, it, I almost bite my tongue, and say that I will do better next time."

Then the Lord does not charge it against you, it is covered. "My little children, I write these things unto you that ye sin not." Guard your weaknesses, your blemishes, your appetites, as carefully and diligently as you can, so they may not overcome you, so that you may not be ensnared by Satan, but if on account of weaknesses, if on account of appetites inherited from the fall, or cultivated before becoming a Christian, or even since, you make a mistake, and you are not in harmony with it, but you immediately confess your sin and ask the Lord for forgiveness, He will grant it, because if "we" the members of the Church, sin, we have an advocate with the

Father, Jesus Christ the Righteous who is the propitiation (satisfaction) for our sins, and not for ours only but for the sins of the whole world.

The plain Bible teaching then is, that all sin committed through ignorance and weaknesses by members of the Church and the world is freely forgivable through the merit of the atonement: "Behold the Lamb of God that taketh away the sin of the world" - of course that includes the Church.

But do not get a wrong thought. If we say something sharp to a brother or sister, or an enemy, if we do anything we know is wrong, and we are in harmony with that wrong, and do not try to make it right, we would be under condemnation, but as surely as we tried to make it right, and all the time appropriate the merits of Christ's death to ourselves by faith, God will regard us as having a clean robe; we thus keep our robes unspotted from the world.

Our Lord said in the sermon on the Mount, "If thy brother hath ought against you, if you know you have wronged him, before you present your offering at the altar, go to your brother and make the matter right, or do what you can to make it right, then come back and I will accept your offering." So then, if you and I knew a brother had been injured by us through some unkind, harsh or unchristian conduct on our part, before the Lord would fully accept us, even if we believed with all our hearts in the merit of the atonement, it would be necessary for us to do all in our power to make that matter right; and in these two ways, appropriating the merits of Christ's death to ourselves by faith, and to the best of our ability righting every wrong, we would be keeping our hearts in the proper attitude before the Lord, and we would be fully acceptable to the Lord, and thus keep our robes unspotted from the world.

Now let me read a little further from John's first epistle, from which we have taken our text. There are some very significant statements in this chapter in connection with the subject we are discussing. Beginning with the 14th verse of the 3rd chapter, we read: "We know that we have passed from death unto life, because we love the brethren. He that loveth not his brother abideth in death. Whosoever hateth his brother is a murderer: and ye know no murderer hath eternal life abiding in Him. Hereby perceive we the love of God, because He laid down His life for us, and we ought to lay down our lives for the brethren. But whoso hath this world's goods, and seeth his brother have need, and shutteth up his bowels of compassion from him, how dwelleth the love of God in him? My little children, let us not love in words, neither in tongue, but in deed and in truth. And hereby we know that we are in the truth, and shall assure our hearts before Him." You see the point: if you love the brethren, if you know you are in heart-harmony with the brethren, and make allowances for their weaknesses and are on the lookout for opportunities to serve them, in temporal ways as well as spiritual ways, then the Lord accepts you as His child, and does not charge your imperfections against you, because we know that we have passed from death unto life.

"For if our hearts condemn us, God is greater than our hearts and knoweth all things. Beloved if our hearts condemn us not, then we have confidence in God." But some one may say, "My heart does condemn me." But why? Well, because I make mistakes and am not able to live a perfect life." That is not the proposition here at all. If your heart condemns you because you make mistakes, or get a little impatient at times and say a sharp word to your wife, or husband, or

children, or neighbors, and you are not in harmony with that word, and you ask the Lord to forgive you, and apologize to your husband, or wife, or neighbor, as the case may be, He will not charge that against you. That is not the subject that is being discussed here. Well, what is it? If we love the brethren, then our hearts will not condemn us, but if we do not love the brethren, then our hearts will condemn us, and God, who is greater than our hearts, will also condemn us. Now let us make it personal, applying it to myself and to all present. Do we indeed love the brethren? Of course, now, we are addressing those who have accepted Jesus as their Savior and are endeavoring to walk in His footsteps. Do we love the brethren? Do we feel like taking them in our arms of love, so to speak, and helping them to fight the good fight, and run the race set before them unto the end? Yes. Well then, your heart does not condemn you, and my heart does not condemn me. What, you are living such a good and perfect life that your heart does not condemn you? I did not say that. I wish I could live a perfect life. I am full of imperfections, I make mistakes every day, but, thank God, I do love the brethren; I love them now a thousand times more than I loved them ten or fifteen years ago, and I find my love increasing for them constantly; I love to be with them. Why just think of it, we have the glorious prospect of living together -- how long? A hundred years? A thousand years? A hundred thousand years? A million years? No, dear brothers and sisters, but for ever and ever. And surely that is one good reason for loving each other now. But that is not the Bible reason; the Bible reason is because we have the Master's Spirit, the spirit of love, the spirit of kindness, the spirit of gentleness. If it were not for our old imperfect bodies, we would be gentle to everybody; our gentleness, our humility, our kindness, and every good quality would be actually perfect. Now we have the treasure in earthen vessels, and the flesh lusts against the spirit and the spirit lusts against the flesh, so that we cannot do the things that we would -- we are not able to serve God perfectly as we would like to serve him. So if you and I truly love the brethren -- which includes love for Jehovah, we are not under condemnation, even though we do make many mistakes and slip and slide sometimes.

He who is pursuing this course in condemning himself is doing what is altogether unscriptural. Do you not think, dear brethren and sisters, that you are reflecting credit on the Lord, and that you are honoring the Lord and His arrangements for your acceptance, even though you are making mistakes, as long as in your heart you know you are trying to keep His law? Brethren, Christ is the end of the law for righteousness to every one that believeth. The righteousness of the law is fulfilled in us who walk not after the flesh but after the Spirit. If while you are doing that you are condemning yourself, you are not honoring the Lord. Just think of the man who takes this position: I am such a weak, insignificant person, making so many mistakes, the merit of the atonement is not sufficient for me. I think you are honoring the Lord and His arrangements when you say this: Lord, I am weak, I do not amount to much, but I am glad you fully accept me in the beloved, and, therefore, dear Lord, while I love the brethren, my heart does not condemn me, and now I have the perfect love that casteth out fear. My heavenly Father, I am not afraid of you now, I love you to the best of my ability, and if I should die now, I would not be afraid of meeting you through the merit of the atonement. That is the love of every true child God may have, not because he is perfect, but because he is fully acceptable to God in the beloved.

I will read a little further: "And whatsoever we ask we receive of him, because we keep his commandments, and do those things that are pleasing in his sight." Again I imagine someone saying, "I cannot do that, I cannot keep His commandments, I cannot do those things that are perfectly pleasing in His sight, and I am not included in this class." And what is the

commandment? And this is the commandment that we should believe on the name of the Lord Jesus Christ. Cannot you do that? Can you not constantly believe that Christ is your Savior, and by faith appropriate the merits of His sacrifice for you? "Yes, I could do that," And what next? Love one another. "Can you do that?" "Yes." Well, then, dear friends, whatever petition you offer God hears and will answer it. Every petition offered by those who have accepted Jesus as their Savior, and love the brethren, God answers in His own time and way.

Now just a few words about the second proposition. In the text from the 10th chapter of Hebrews now under consideration,--having our bodies washed with pure water. First, we are sprinkled from the consciousness of evil, and, second, our bodies are washed with pure water. Suppose a person had his heart cleansed from the consciousness of sin, suppose he accepted Jesus' merit by faith, thus appropriating it to himself, and went no further, what then? Dear friends, he could not while in such an attitude of heart, continue in a condition of peace with God; he could not remain under the cover of Christ's righteousness; he would lose the robe that Jehovah gave him. In order to remain under that robe, he must develop character, he must add to his faith the characteristics, the qualities, of the Spirit. Peter enumerates them: virtue, temperance, patience, knowledge, brotherly kindness, love. In other words, he must cleanse himself, in the manner Paul explains in the 5th chapter of Ephesians, through the washing of water by the Word.

Now, my dear brothers and sisters, when by faith we appropriate the merits of Christ's death to ourselves, we are not actually washed, but our past sins are forgiven; they will not be charged against us again; our present imperfections and blemishes and sins are covered. In order to make us acceptable to God as overcomers, to obtain eternal life, we must be cleansed by the washing of the water of the Word; we must permit God's holy Word to influence our hearts and lives. Clean water washes away the defilements of the flesh. Now the Lord's glorious work is beautifully illustrated by clean water, which washes away the defilements of the mind and flesh, as Paul suggests in the text, "Be ye not unequally yoked together with unbelievers; for what fellowship hath righteousness with unrighteousness? And what communion hath light with darkness? And what concord hath Christ and Belial? Or what part hath he that believeth with an infidel? And what agreement hath the temple of God with idols? For ye are the temple of the living God; as God says, I will dwell in them, and walk in them, and I will be their God, and they shall be my people. Wherefore, come out from among them and be ye separate, and touch not the unclean, and I will receive you" (2 Cor. 6:14.) "Having therefore these promises, dearly beloved, let us cleanse ourselves from all filthiness of the flesh and spirit, perfecting holiness in the fear of God" (2 Cor. 7:1.)

Some dear people make the mistake of believing that God does all the cleansing -- they simply submit to Him and He does all the work. They are mistaken in this; the cleansing He does is provided in the merit of the atonement and is a reckoned cleansing, actually forgiving the past sins, but covering the present sins, blemishes, etc. Then, He has provided also certain mediums through which the actual cleansing may be accomplished. When I say actual, I do not mean absolute; but every one who is to be made like his Master must cleanse himself as much as he can. "Whoever has this hope in him, purifieth himself, even as He is pure." Does he say the Lord does all the purifying? As soon as a person accepts the Savior is he made perfect or clean? No, the cleansing only begins then; his heart is clean, but he has the defilements of the flesh -- the motions of his flesh are not in harmony with God's righteousness, and the more he studies the

good Word of the Lord, the more he recognizes those blemishes and weaknesses, and if he is in a proper attitude toward the Lord, the stronger effort he will make to cleanse himself. He learns from the Lord's Word that it is wrong to think evil of anyone, that it is wrong to meddle in other people's affairs, to discuss his neighbor's affairs unnecessarily. Perhaps when he first became a Christian, he may have thought it was commendable to talk a little about his neighbor's affairs. Perhaps he was not interested in Bible subjects, being only a babe in Christ, but having a larger measure of the Master's Spirit he does not want to discuss his neighbor's affairs; he recognizes that is the spirit of the world, and he does not want to give that spirit the least encouragement. And how did he get into this attitude of mind? It is the washing of the water by the word, the blessed Word of truth, enlightening, cleansing and purifying.

Now, my dear friends, I understand it is this kind of water that is mentioned in our text -- "There are three that bear witness in earth, the Spirit, and the water, and the blood" -- the spirit, the Word and the blood, if you please. We understand the water the laver in the court of the tabernacle contained represented this anti-typical water, the precious cleansing of the Word of God. You remember of what the laver was made. It was made of copper. What kind of copper? It must have been a highly polished copper, of a finer quality than ordinarily used. You know how it was supplied or furnished. The mirrors the women of Israel used at that time were of polished copper, and they contributed their mirrors. They probably did not contribute them all, but they contributed them in sufficient quantity to make the laver, and now that laver was of a finer quality of copper than the other copper in the court. And that brings to mind the fact that our dear Redeemer was actually perfect as a human being; he had a finer nature than those who became His footstep followers; the copper in the court represented their reckoned human nature, and that laver evidently represented our dear Master's perfect human nature. Now in the type the copper for the laver was furnished by the women of Israel, the women who were interested in the construction of the court of the tabernacle and the services there, etc., and the antitype of that we think is this: that the perfect man Christ Jesus was made of a woman, not of a man. He did not come from a man. Jehovah did not say to Eve, after the fall, the seed of the man shall bruise the serpent's head, but the seed of the woman. He was made of a woman, under the law. If he had been of the seed of the man, He could not have bruised the serpent's head. He could not have died; He Himself would have been under Adamic condemnation with the rest of mankind, as our dear Brother Russell very beautifully and scripturally explains in the Fifth Volume of the Scripture Studies.

Now, dear friends, in the New Testament Scriptures we read about the women ministering to the Lord of their substance. We see from these texts, and others also, that the Lord has conferred very great favor on the women in connection with His work, in connection with the propagation of the Gospel, etc. You remember, how, at His first advent, a woman who loved Him before He was crucified, broke an alabaster box of precious ointment and anointed His feet, just a short time before He was crucified. And you remember how His disciples murmured, saying, this could have been sold for so much money and the money given to the poor. Jesus said, do not interfere with her, she has anointed me for my burial, and whatever the Gospel is preached in the whole world, this that this woman hath done shall be declare. It is being declared now, dear brothers and sisters, and I presume it will be throughout eternity. I would say to the sisters tonight, Continue to break your alabaster boxes of ointment, anoint the feet of Him, anoint those who constitute the feet of Christ, those who are walking in the narrow way. Our dear sisters do



not realize fully, I am sure, how much they are helping along the glorious work that is now in progress; they are encouraging the brothers and the sisters who are the members of the Lord's Body generally. So I say to you, while you have not the same opportunities that the brothers may have in the way of holding public meetings, etc., you have opportunities that they do not have, opportunities that they could not use, in your gentleness and meekness, and kindness, etc., encouraging those who are in the work, and, thank God, the sisters are doing it. All the brothers who are in the work, and the sisters also, are receiving a great many blessings through that channel, and I want to say to you, dear sisters, we appreciate it, and we are glad to think of the good time coming, when we shall all be changed and there will be no difference whatever. There is no difference now, in Christ; we are all one in Christ. There is no difference in respect to our new natures. There is still a difference in the old nature, and by and by we will all have the new nature in its perfection. "It doth not yet appear what we shall be, but we know that when He shall appear, we shall be like Him, and see Him as He is."

Now we think we can understand a little better what Jesus in the 19th chapter of John meant. Our dear Master, when He expired on the cross, exclaimed "It is finished," and the soldier pierced His side, and blood and water flowed. Mark in this text, the blood comes first -- blood and water flowed out. We all at once can comprehend what the blood meant, but perhaps we do not understand so well what the water meant. I am sure I did not until I began to associate it with the water that the laver contained. There is also the antitypical laver, the Man Christ Jesus, who poured His soul out unto death, giving His life for the world, and there water flowed out, illustrating and representing the Word of God that cleanses those who receive it into their hearts, permitting it to influence their lives and cleansing them from defilement, helping them to cultivate the fruits of the Spirit, helping them to get ready for the glorious position to which that they will soon be exalted, joint-heirship with the master in the kingdom.

A few concluding words with respect to the Spirit. Every disciple has the blood, every disciple has the water, the precious Word of the Lord, and now every disciple has the Spirit, a measure of the same Spirit the Master had. He does not have it in its fullness as the Lord possessed it. You remember our dear Master when He was baptized of John received a power He did not possess previously. The disciples received a similar power, only not in its fullness, when they were baptized in the upper room in Jerusalem. Now that holy Spirit is God's holy power. It did not come to Jesus directly through the word as it does to His consecrated followers, but Jehovah sent it from heaven to the waiting disciples. You remember Jesus said to His disciples, "It is expedient for you that I go away; for if I go not away, the Comforter will not come unto you; but if I depart, I will send Him unto you." He ascended to heaven, and ten days later the holy Spirit was bestowed on the Church, and the Spirit has been with the Church ever since. It comes more through the Word than it did to the dear Redeemer and to His disciples, who constituted the nucleus of the Church. Those who accept the Word, who believe the teachings of the Word, and consecrate their lives to God, receive the Spirit, and yet, dear friends, God's holy Spirit, or power, is something that actually exists in a person's heart. I mean it is a powerful influence that acts on His mind and inclines it heavenward, so that he now takes interest in heavenly things, which he did not take before he became a Christian. I do not mean that a person comes into the body, but it is a new desire which he did not have before he consecrated himself to the Lord. Before that he was solely interested in earthly things -- not necessarily vicious or immoral things of earth, but nevertheless in temporal things only. Now, under the influence of God's holy Spirit,

we are seeking the things above, endeavoring to lay up treasure in heaven, and that is why we talk about heavenly things. When the Lord's people lay up treasure in heaven, they like to talk about the treasure. If their hearts are up there where their treasure is, they discuss those things. People of the world discuss earthly things, their possessions and money, their farms, etc. I trust by God's grace, you and I are laying up treasure in heaven, and we can see that the majority of the Lord's dear people are indeed laying up treasure in heaven, because they like to talk about heavenly things. That is their intention. For where a person's treasure is, there will his heart be also. So you have something tonight that you did not have before you consecrated your lives to the Lord. A new body? No. You have the very same physical head and body that you had then. What have you now that you did not have then? You have a new mind. "Let this mind be in you which was also in Christ Jesus." We have the mind of Christ. "If any man have not the Spirit of Christ" -- God's spirit in His Word, operating on his faculties, inclining them heavenward, and as Paul intimates in his text, "Be not conformed to this world, but be ye transformed by the renewing of your minds, that you may know what is that good and acceptable and perfect will of God" -- he is none of His. And, furthermore, in the Word of the Lord a very plain distinction is made between this new mind and will and the disposition called "motions of sin in the flesh." Some of our dear friends confuse these two things. They seem to think that a motion of sin in the flesh, a wrong thought or a wrong desire, is the will. Why, if that were true, you would have a number of wills. There are very many different faculties in the human head. We have been told there are more than forty mental faculties. If each of these had a will of its own, you would probably have a hard time. You have a hard time as it is, but if all of these had a will, perhaps they would all be against each other, and you would have a terrible battle indeed. But every consecrated child of God has only one will, and that is to please God; he is not a double minded man; he is not unstable, he is always saying, "thy will be done." This is the narrow way our Master trod; He was misunderstood. His name was cast out as evil. The servant is not above His Master. The new will keeps this disposition of the flesh under control, but it will always give you some trouble. Some of the dear friends think it is the devil that is giving the trouble directly, but he is not with you very much of the time. He cannot be with you always; he has a lot of business to attend to in the world; he is over in the other countries part of the time. Your old flesh is with you every moment, and whether waking or sleeping, it is giving you trouble. I met a good brother sometime ago who, before he became interested in the truth engaged in what is called a social game of cards, occasionally, and he said in my presence to some of the friends. "I am glad I am not responsible for that dream." On the way home some of the friends explained to me why he made that remark. Some time previously he had a dream that he was playing cards, and enjoying himself, and a brother of the truth came into the room where they were playing. Oh, he said, is not this mortifying? Is not this terrible? Here is this truth brother who finds me playing cars! He said, "I awoke and found it was a dream, and I thanked God that I am not held responsible for my dreams, or for the motions of sin in my flesh that might produce these dreams, the unbalance of my faculties, etc."

I remember sometime ago, I dreamed a little along this same line. You know the Bible says, he that hath a dream, let him tell it, and he that hath a word, let him speak it. This is not the Lord's Word, but only a dream. I used to use tobacco before I came into the truth, and for a while after I came into the truth, and I have much sympathy for our dear friends who use tobacco, and have not got entirely free from the appetite, and I have no unkind criticism to offer, I fought a very hard battle to get that thing under control. I thought, in my dream, I was chewing tobacco again;

I was in the company of some brothers and sister, too, but it seems they did not object. Somebody looking out of the door said, Here comes Brother Barton. I knew Brother Barton never did use tobacco, and is naturally a very clean man in every respect, and when I saw him coming, out went the tobacco, and when I awoke, I was glad the Lord did not hold me responsible for the dream.

I thank you for your kind and close attention.

**FRIDAY, OCTOBER 4.**  
**9:30 A.M. -- Praise and Testimony Meeting**  
*led by Brother A. E. Williamson.*

This service opened with hymn No. 15, "Hope in Christ" -- "Ask me what great thing I know that delights and stirs me so." Prayer by Bro. Kuesthart.

Bro. Williamson remarked about the "Cross" and how so many in the world are finding the "Cross" to be a stumbling block and foolishness. He said we rejoice as we consider that one by one our dear ones are passing over, even in the midst of such circumstances as took the two precious ones at the beginning of this convention, with whom we were very familiar. We are not saddened and overwhelmed, for the feeling of joy and thanksgiving are greater than sorrow and our hearts are filled with thanksgiving as we see that our two brothers whose companions were taken away are here with us again in this Convention.

The particular thought impressed upon my mind this morning, is that if we are looking for that glorious change, and if we expect to participate in it in due time, we will have to be made ready for it. Not one of us who has a covenant with the Lord will be permitted to pass the portals that lead to the Kingdom unless the Spirit of God is working in our hearts to perfect character that He wants. If by some mischance, which of course is impossible, we should be translated into the Kingdom before we were ready for it, we would beg and plead with God to send us back to earth, because we would not find ourselves in position to enjoy the blessings of the Kingdom. The glories of that Kingdom are so immeasurable from a human standpoint, and as we are governed by human conditions, we cannot, before our change, appreciate or enjoy the conditions that belong to the Spiritual Kingdom of Heaven. So the Apostle lays it down very emphatically; "Eye hath not seen nor ear heard, neither have entered into the heart of man the things which God hath prepared for them that love Him." If it has not entered into their hearts, they cannot take hold of it or appreciate the condition when changed. The Apostle goes on to give us the blessed assurance that may stimulate us. He says, "but God hath revealed them unto us by His Spirit; for the Spirit searcheth all things, yet, the deep things of God."

Now, dear friends, we have the spirit of God's grace, the earnest of our inheritance so that we may be able to familiarize ourselves with the conditions God expects us to use. Such as to make us ready to appreciate the conditions of the Kingdom by putting them into our daily lives.

We would like to hear testimonies from all; some do not testify because they feel that they must speak along some particular line, and they think no one wants to hear of their trials, etc. And as

they do not feel they are bubbling over with joy, they think they had better keep still. That is a great mistake and a testimony is desired from all whether of joy or whether telling of the troubles, etc., that the Lord is permitting to come to test and to perfect the characters.

Sister Conklin: We have a fruit farm and Brother Conklin and I wanted to sell our farm so we could get into town where we could have the fellowship of the brothers and sisters. Well not a single customer has been near that place, but the Lord answered our prayer for fellowship, by bringing the brothers and sisters to our home and our class has increased in number, and so if we do not sell it at all He has answered our prayer. I love the Lord and I want to be faithful. Don't forget to pray for me because I stumble and fall and have to get up again. This is a FEAST.

Brother Staples, Richmond, Va.: I have been set thinking since yesterday because of the testimonies of two brothers who spoke of trouble in their homes. These two brethren mentioned something of the breach that had been made in their families which was caused by the Truth entering in. My experience has been a little along this line. With sorrow I have to say that my companion is not in the truth. While a very dear wife, she seems to take no interest in the precious things that stimulate our hearts. In early marriage I had to pray a good deal to find God's will in the matter. The leader said yesterday that perhaps these brothers had talked too much. This is the point; -- a consecrated child of God surely ought to be able to live with any reasonable creature on the face of the earth in some degree of harmony and love. I called to mind a silent sermon, when our Savior preached to the spirits in prison and I determined to emulate Him, feeling that it would be the best sermon. So, dear friends, I want to say if you will just ponder and pray over the matter looking to Jesus as the example and follow Him, you will get help. His sermon was His life, His death, and His resurrection. They saw something in Him that they did not see in father Adam. I now find in my household it is the pleasure of my life to be with the dear ones. I find my wife has mellowed down to my astonishment and will help me to any reasonable extent. I ceased to call her by name but "my dear," "my darling," "my precious one." And when coming in from work I would ask how are you my dear, are you well, etc. Try it dear brethren.

Brother Causer; It seems like a peculiar thing that the brother from Richmond and I had thoughts travelling very much the same way; I had an experience with my wife, but not because she opposed the truth. When I first came into the truth, some thirteen or fourteen years ago, I was probably like some of the rest of you; the truth was so grand and invigorating that we wanted to give it to somebody, and, like untrained soldiers, we could not handle the sword in the right way; we used it more like a club. I was so impressed with the truth and so anxious to handle it that I wanted to knock down everybody that did not take to it. For a number of years our dear Brother Williams and I were the only ones in the town who had the truth; every Wednesday evening we studied the Scriptures and we grew thereby. Our wives did not come to the meetings very much at first, but it was our hearts' desire that they should come. After a while our meetings grew and we began to gather in others from the outside, but my wife did not have ambition to get out and attend the meetings, although she knew I loved the truth, and would lay down my life for it. I never knew why my wife would not attend meetings until Brother Van Amburgh came there and preached on the subject: "Love In the Home." Then my eyes were opened a little bit, just a little bit; I began to see something. He showed me that our love was to the Father and to the Lord Jesus and my wife and children came next. They were my second responsibility; outsiders come

after them. I was the leader of the class at home for a number of years, and of course in order to bring out all there was in the lesson, I used to spend a great deal of time studying and I used to neglect my wife and children. Brother Van showed me how it was. I would sit down and study and study to get the meat for the brethren, but she was neglected. She got up, got the breakfast, washed the dishes and did all the work and when meeting came, she was all tired out, worked up and nervous, and she could not go. Brother Van said, "Do you love your wife?" Yes I do. "Do you leave her to carry up the coal from the cellar?" Yes. "Do you help her to sweep out the rooms?" No. We have four big boys home and it keeps us busy to keep them in order and I was leaving it all to her; I was not attending to my second love. I said, Brother Van is right; help her and see if she can't get to meetings once in a while. When I came to that conclusion, I got up the next Sunday morning, helped her to get the breakfast, brought up the coal and helped her sweep and do all the work. There was not a happier man in this Convention than I was, when my wife got up in this convention the other day and said she was trusting in the Lord and running for the prize. Do not take the truth as a club to knock your wife's brains out, call them dear, darling, etc.; they are dear, I love them and I want to do them good. My wife does not say how as she used to, "Pop is going to Heaven and does not care for the rest of us." I want her to go with me, and she is going to help me to be an overcomer, and I am going to help her.

A brother: I was thinking about how as stones for the Temple we are being chisled, shaped, etc., so as to fit. Sometime ago while in a restaurant the waiter did something which caused me to make a very sharp remark to her; after leaving the restaurant, the brother with me put his arm around me and asked if what I had said was in a Christ-like spirit? I saw my mistake and was very sorry. Since coming to this convention I had a somewhat similar experience; the waiter spilled a boiled egg all over me, and I felt a good deal like I did before, but the Lord helped me and I never let it out. I hope that if the Lord ever lets me have another experience, the sharp words or desire to say them will not even be there.

A brother: I have made many mistakes along the way, but inasmuch as I did not do these things intentionally, the Lord has not held them against me.

Brother Thornton: My troubles are not with my wife nor children, nor the brethren, but with myself. The cares of life that I have allowed to come upon me are the ones that are making me trouble. The cares of this world have choked out the cares of the Lord's work. I have been choked some. I want to get rid of all the cares possible.

I felt it my duty to provide things decent, etc, so looking at these various things, I have allowed the various incumbrances to hinder me. My ambition has been to provide an estate, something for my family and then the Lord could have all the rest of my time. In Bro. Cole's remarks yesterday, he said, have you enough to keep you eighty-four months? I figured up and said, yes, enough for three times that. I spent a great deal of time with Brother Russell yesterday; I was pouring out to him my trials and trouble and I want the prayers and assistance of all, that the Lord may give me grace and strength necessary to come to the proper decision.

## 11 A.M. -- Discourse

by Brother M. L. Staples, of Richmond, Va.

Topic: "The New Creation."

(Note: We again remind the friends that our report of the three general conventions this year has reached very large proportions, and in this instance, as in one other, we have had to give only an account instead of the discourse in full.)



Brother M. L. Staples.

It gives me pleasure, dear friends, to look into your faces this morning, especially as this is the first time I have had the pleasure of attending a general convention in the state of Virginia.

The subject announced for this forenoon is one with which we are all familiar -- "The New Creation." Those who have familiarized themselves with the thought in the 6th volume of Dawn already have before their minds far more than I could hope to present to you in the short period of time I have to talk. There are so many texts of Scripture bearing on this subject that any one would do as a basis for what we have to say. But upon the program you will notice that we are given Paul's letter to Timothy, 3rd chapter and 15th verse, "But if I tarry long, that thou mayest know how thou oughtest to behave thyself in the house of God, which is the Church of the Living God, the pillar and ground of the truth."

This brings us to the consideration of the fact that our dear heavenly Father in His wonderful plan proposes to have a New Creation of being, in whom He can dwell, and with whom He can have perfect communion, fellowship and harmony -- a New Creation taken out of the world and made fit for His use, bringing them up to the divine nature, making them such beings that He can dwell with them, so to speak, associate with them, and use them for the duties to which His wonderful mind may look forward to see in ages to come.

Our mind is called just here, dear friends, to the wonderful and important plane of the great "I AM" as brought to our notice through the Prophet Isaiah. Our Heavenly Father, speaking through the Prophet, in the most positive terms declares, "I am God, and there is none else." He tells us that as He has thought, so it shall come to pass -- not may come to pass if the devil permit, not may come to pass if I can bring it to pass, not, as many are in the habit of saying, I will try to bring it to pass, but with absolute certainty and positive ness. As I have thought so shall it come to pass. And this gives us great confidence in our Heavenly Father.

We notice that our Heavenly Father declares to us through the same Prophet that He sees the end from the beginning; that He stood, as it were, by the creation of man and took a general view, and His wonderful, gigantic mind penetrating all the various features circumstances and conditions of this long period of time, conceived a plan by which He could glorify Himself -- and He made man for His glory we read, and He formed the earth to be inhabited -- looking down with the great powers of His mind on the various animals and the various creatures that make up this universe of ours, we can imagine Him saying something like this, or thinking something like this: Here we have very many beautiful animals, and here we have the green earth, and here we have a great variety of creatures, the workmanship of our hands, but yet there are none amongst all the created ones that are able to take control; therefore let us make another animal, in our

likeness, in our own image; let us make one of higher qualities than the horse, the cow, and the other animals; let us make an animal now in our likeness, with reasoning faculties and powers; and let us give him dominion over all the other s that he may bring them into perfect subjection to his mighty power; and we will make him the king over all the earth. Thus he formed of the dust of the earth Adam, the progenitor of the human race, and placed him over the work of His hands. And I love to let Paul tell the story, as he quoted from the 8th Psalm, when he says: "But we see Jesus, who was made a little lower than the angels for the suffering of death, crowned with glory and honor; that He by the grace of God should taste death for every man."

Brother Staples then briefly reviewed the history of creation of man, his trial in the Garden of Eden, and his fall; and speaking of the degradation of the race, said: "I call to mind a little statement by an English writer, as follows: 'No wonder that men do wrong by design, but the great wonder is that men do not do right through mistake.' I think that is really worth thinking of. Satan is here and is leading wrong, and instigating wrong, but the wonder is that more men do not make a mistake and do right in the midst of all of this."

Brother Staples then briefly reviewed the history of the race, and God's dealings in the different periods of time down to the birth of Christ. Then asked and answered the question why Christ came, from the stand-point of the ransom, which he said was the cardinal doctrine of the Scriptures. And then how we see Jesus -- first as a glorious spirit being, the first begotten Son of God, and next we see Him humbling Himself and becoming a man for the suffering of death, and next see Him and becoming a man for the suffering of death, and next see Him exalted to the divine nature, next to the Father in power and glory.

This brought the subject down to the work of the Gospel age, the selection of the New Creation. Brother Staples considered the different figures used in speaking of this New Creation, and more particularly that of the Temple -- how the different stones of which this Temple is composed are quarried away from the Temple site, where they are afterwards assembled for the placing together in the grand building. He then closed the subject with a touching exhortation to those who have made a full consecration to be diligent in making their calling and election sure to a place in the great anti-typical Temple, the Church of the living God.)

## Brother M. L. Staples.

3 P. M. -- Discourse by H. C. Rockwell, of New York, N. Y. Topic:

### "The Great Pyramid's Testimony."

BROTHER Rockwell spoke, in substance, as follows:



Brother Rockwell.

Dear friends, we have selected the words of the Prophet Isaiah, 19th chapter, 19th and 20th verses, as the basis for our re-marks this afternoon. The words of the prophet are: "In that day shall there be an altar unto the Lord in the midst of the land of Egypt, and a pillar at the border thereof; and it shall be for a sign and for a witness unto the Lord of Hosts in the land of Egypt."

We believe, dear friends, there is but one building in all the world that would fulfill the conditions of this prophesy. Naturally our attention would be directed to the land of Egypt to ascertain what the prophet was alluding to. Situated on an elevated, rocky plateau, or plain, overlooking the valley of the Nile, stands the most wonderful structure in all the world. It is also conceded to be the oldest building, and how appropriate it would be if we would find this building to be a corroborative witness of the oldest book in the world. How fitting that the oldest and grandest building ever erected by man should be the corroborative witness of the oldest and the grandest book -- our heavenly Father's Word.

Before we consider the passages and chambers of the interior of the pyramid, as represented on this chart, we will consider something of the exterior of the pyramid, its location, etc., to see whether it really is that witness, and in what respect it would be a pillar, and a sign, and an altar.

In considering the prophet's words, "In that day," we believe from the text in the 19th chapter of Isaiah that the prophet was speaking of a special day. Oh, dear friends, it is that happy day, that glorious day of the Lord of which we have just been singing; it is that day of the Lord of which one of the prophets speaks when he says that the Lord would be king over all the earth in that day. In other words, it is the thousand year Millennial day, the thousand year reign of our dear Redeemer and Lord. And we have the evidence of the Scriptures, as well as the evidence of the fulfillment of prophecy that

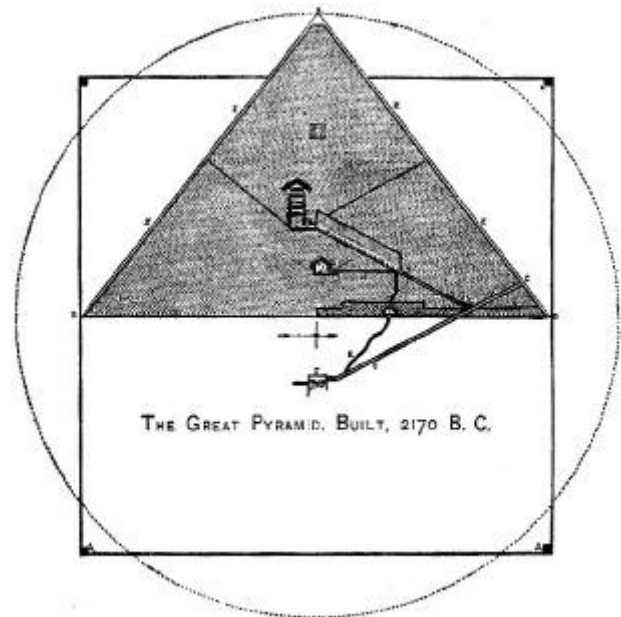



we are already living in that day; that is, we are living in the period when the Gospel and Millennial ages overlap, so that it can be truthfully said, we are living in that day. And that is the reason, we are enabled to appreciate the pyramid, and see that no doubt it is the stone witness of the Lord, because it was to witness in that day; and the fact that it was to witness at a particular time, when it would begin to witness would be a proof or sign that we were living in that day. So we see how the pyramid fulfills the other condition here mentioned by the prophet, that it should be for a sign unto the Lord of Hosts in that day.

Well now then, how would we consider it as an altar, or a pillar? My understanding of the matter is this: That the word "altar" has not only the significance of a place where sacrifices are offered to God, but it is a place where religious worship, and prayer, and devotion, may be made to the Almighty God. You are all familiar with the fact that in all the churches of the day they have altars situated in the most prominent part of the church where the people kneel down and offer prayer, etc. So I understand that this pyramid during the thousand years when the world of mankind is coming to a realization that it is indeed God's stone witness, that Jehovah is the great architect, that naturally, or we may say instinctively, as they would come to examine the various features of the pyramid, their prayers would go up to God; it would be a place of worship. The pyramid is located in the geographical land surface of the earth. Some of my dear hearers may not be familiar with what we mean by that statement. We will suppose that the whole earth's surface was spread out on a level plain, North and South America in the west and Europe, Asia and Africa in the Eastern portion of it. When we would come to examine the geographical surface of the earth, we would find that the great pyramid of Egypt is located exactly at that point. Well now, we can readily see how that when all the nations of the earth come to a realization of the wonderful things that are occurring in Jerusalem (Jerusalem will undoubtedly be the capitol city of the world during the Millennial Age, that it would be the most convenient point for all the people going up to Jerusalem to incidentally pass by this great pyramid, this great stone witness of our Lord) they would naturally examine into the wonderful things that pertain to the pyramid.

Looking at the location of the pyramid in the land of Egypt, we find that in one sense it is in the midst or center of the land of Egypt, and at the same time at the border thereof. Now that seems like a paradoxical statement. How could anything be at the center and still be at the border? The whole northern part of Egypt, commonly known as lower Egypt, is a sector-shaped land. The seacoast is circular, and the diverging lines come together, or converge, at a point, and the pyramid is right at this point where these two boundaries, as it were, come together; and the center of the sector is the point where these lines come together. So you can see how the pyramid could be at the center of this sector-shaped land of Egypt -- in the midst of the land of Egypt. And it is also at the border because this is at the border of this lower land of Egypt. So it is also at the center and at the border of the land of Egypt.

In our study of the Scriptures, I trust we have all found that Egypt is symbolic of the whole world, and that Pharaoh was a type of Satan, ruler of Egypt, just as Satan is the ruler of this world; he is the god of this present evil world. So looking at it from the larger standpoint, we see that the pyramid is in the geographical center of the whole world. Now how could it be at the border thereof? I understand it 'this way: We all are familiar with the fact that the world is a globe, and of course any part of that globe might be considered the border, but in a particular

sense we might say that the pyramid is located at the border of the world. In other words, it lies between the occident and the orient, the east and the west. The meridian upon which the great pyramid is located would be the natural boundary between the Eastern and Western countries, and so you see it would be at the border, as it were, between the occident and the orient.

Then we would understand the expression, "Pillar unto the Lord of Hosts" in this way: That it is a pillar in the sense of meaning a monument unto the Lord. That great pyramid is indeed a wonderful monument. As we have just remarked, it is the greatest structure in the world. It is 486 feet high and 726 feet broad at the base. It's estimated cost at the present rate of masonry work would be something over forty-five millions of dollars, and engineers who have examined the structure say that it undoubtedly required the services of at least one hundred thousand men for a space of twenty years. So you can gain some conception of the wonders of this remarkable structure. It is just like our heavenly Father to use the grandest and most wonderful structure in all the world to be the corroborative witness of His Word. So this pillar would be a standing monument unto the Lord of Hosts, attesting God's wisdom and foreknowledge, and power, in arranging it as He did to foreshadow the evidence of His Plan as revealed in His Word.

Now this pyramid reminds us of the Bible in many respects. As the plan of God was sealed in the Bible for centuries, thousands of diligent Bible students having read and reread the Scriptures and having gone back to some of the oldest documents to get the most correct translation, and yet with all their efforts, time and again trying to understand the mystery of the Plan of the Ages, they could not find out what the divine purposes were until the due time. So it is with this pyramid. Its witness was not due to be understood or made known until that day of the Lord. And now, dear friends, we are privileged to rejoice and be glad in this corroborative witness, giving us that much more foundation for faith, as it were, in the things of our God.

There are in the neighborhood of seventy other pyramids located in the vicinity of this great pyramid, but all of these others are inferior in every respect to the great pyramid, and we notice in examining the others that none of them contained the upper chambers and passageways as represented on the chart here. Most of them have this descending passage with this subterranean chamber, and this is a proof that the others are but imitations, or copies, of the great witness. Well now, how was it that the builders of the other pyramids did not imitate the great pyramid in having those upper chambers and passageways? It was this way, dear friends: These upper passages were concealed until the year 825 A. D., when Al Mamoun, an Arabian calif, endeavoring to find treasures in the great pyramid, quarried his way from the outside into this portion, and as they were working along there, a three-cornered stone that blocked the entrance to the first ascending passageway was dislodged from its place, dropping down into the descending passageway, and there for the first time was revealed the way to these upper chambers and passages.

We believe, dear friends, that was designed of the Lord to conceal these things until the due time. Now what significance would these other pyramids have? My thought would be this: That if there was any significance at all it would fittingly represent the various other churches and denominations, the various religious sects and bodies in the world, professing to be churches of Christ and professing to be preaching the Gospel. But now we find, as we examine into the doctrines and teachings of these other various churches, that in place of pointing out the way of

life and immortality, making clear or explaining the mysteries of the kingdom of heaven, and pointing out the future day of salvation for the world, they are all busily engaged in pointing out the way that leads to destruction. You know the general teaching of the churches is to the effect that this life ends all probation, that there is no hope beyond the present. In other words, the Lord designed that His elect people would be saved, but that all the non-elect would be destroyed. And that would be fittingly represented by the fact that they all have the descending passageway, which we expect to point out to you represents the downward course of the world towards destruction; they are all busily engaged in that; not only claiming the world is lost, but is doomed to misery and everlasting torture.

Now, dear friends, we will take up the chambers and passages located in the interior of the pyramid. We shall endeavor to point out the significance of each one as corroborating our heavenly Father's Plan. We believe the Bible is sufficient that the man of God may be thoroughly furnished unto all good works; therefore we should not expect to find anything in the great pyramid that would teach things additional to the Scriptures, that would bring some new item of truth before our eyes. No, no, it is merely a corroborative witness; we believe our heavenly Father's purpose in bringing these things to His people at this time is that they might have a stronger foundation for faith; for undoubtedly we are living in the evil days spoken of by the Apostle, that evil day when it would be necessary to have on the whole armor of God that we might be able to stand; that those who were anxiously seeking to make their calling and election sure should avail themselves of all the help, and utilize all of the privileges, the Father would grant to them in order to stand in that time. And so as a further means of strengthening our faith, and as an attest to our Heavenly Father's love and interest in His children, we understand is the reason why these things are revealed to us at the present time, although primarily the witnessing of the pyramid was designed for the whole world during the Millennial Age.

This direction of the chart is North and this is South. So when we speak of the north end of a passageway, and the south end of a passageway, you will have your bearings, and you will know what we mean. The pyramid is facing towards the North, and on the north side is an entrance-way leading into this descending passage.

This descending passage-way is about one hundred and fifty yards long, and it is only about four feet high. We believe this is a very appropriate symbol representing the course of the world from the time of Father Adam's disobedience down to the time when the present evil world will go into a great time of trouble and be completely destroyed, as represented by this subterranean chamber, or as it is sometimes called, the bottomless pit. It well represents the bottomless pit spoken of in the book of Revelation, because the ceiling and sides are finished, whereas the floor as represented here is uneven and rough. This bottomless pit represents the condition of death, or destruction, from which there will be no resurrection or restoration. Whatever goes into that pit, or whatever is represented as going into that pit, will never be restored. So the whole world has been on a downward course to destruction for the past six thousand years. At the very beginning considerable light shown into the passage-way. How beautifully this represents the condition of the world having a perfect start in Father Adam. The law of love, wisdom and justice was engrained into man's very constitution; Adam had written in his heart the attributes of God's character.

Well now, as the race started off on the downward course, the way to destruction, it rapidly deteriorated, going down more and more and that original light that was manifested in man's very constitution was gradually eliminated, until the darkness was intense. And so at the present time, looking out over the world, we can realize the force of the prophet's statement that "darkness covers the earth and gross darkness the people."

Dear friends, I think here we have a remarkable proof of the fact that the world is constantly inclined downward, and never upward. You know it is the thought in the minds of many of our dear Christian friends that the world is growing better; that it has always been working up from lower conditions to higher; especially is that the theory of the evolutionists, who state that man originated as a microbe, or protoplasm, and developed through countless ages to the monkey stage, and then on up to the present degree of development, and they proudly speak of this as the brain age, and that by and by man will develop into something higher by his own efforts. But we have it in God's Word that the inclinations of men's hearts are downward continually. And then we note the experiences of the various peoples in the past: we note in the first period of time, marked out in the Plan of the Ages, which we call the first dispensation, a space of 1,656 years, the world had degenerated to such an extent that the Lord looking down from heaven saw that the imaginations of men's hearts were evil continually.

Then again, the race had another start in Noah, the first dispensation coming to an end with the flood, Noah and his family being saved. It was a very good start, but in less than five hundred years, the world had deteriorated so rapidly that in those two cities of Sodom and Gomorrah there were not ten righteous persons to be found.

And then we note the Lord's dealings with the Jewish nation. With all the favors and assistance rendered that nation, there was not one who was able to keep the law and to obtain life, and we note that they were so heart-hearted and so disobedient that when the Son of God, our dear Redeemer, presented Himself to them as their Messiah, or King, they rejected and crucified Him. So, dear friends, with all of these experiences of the past, surely the world, and especially the dear friends in these other churches, ought to learn that the tendency is downward and not upwards.

The height of the passageway is only four feet. You can imagine how, if you were going down that long passage only four feet high, and at a steep angle, after proceeding for some distance, your hack would begin to ache, and possibly your head would begin to throb, and you begin to groan, and perhaps you would begin to think it was a hard and unsatisfactory way, and you would begin to say, probably, is it worth while?

Now, how beautifully this represents the condition of the world. It is a groaning creation, the Apostle says. -- the whole creation groans and travails in pain until now -- groaning and going down, down toward destruction.

After continuing for a long distance, we reach a place dear friends, when we speak of the world, we do not always refer to the literal earth, nor do we always refer to the people inhabiting the earth, but we refer to the world in the sense the Apostle Peter refers to it, -- the evil condition, the evil dispensation, the social order, as it were; and so we find there is a time coming when this

present evil world is to be utterly destroyed, date designated for the great time of trouble, when all the evil institutions and governments will go down and be destroyed, is 1915; -- that marks the beginning of it.

Now we find this pyramid marks out the time of the end of the trouble. A question in the minds of many of the friends is, What will be the end of the great time of trouble? We are all familiar with the fact when it will begin, but when will it end? Up at the top of the first ascending passageway, at the beginning of the grand gallery, the thought was first suggested by a young Scotch engineer, that the years of our Lord's life are represented at the beginning, or the North end, of the grand gallery up to the opening in the well -- the upper opening at the head of this first ascending passageway and lower opening down into the descending passageway. This well, then, would represent the death of our Lord Jesus Christ, and the arrangement at the opening of the well very beautifully represents the resurrection of our dear Redeemer, be-cause it has the appearance of an explosion having occurred there at some time, the solid stone railing, of ramp stones, as they are sometimes called, that run along on each side of this passageway, -- the grand gallery, as it is called at this point, -- seems to have been blown away by some terrific force. We believe it was providentially arranged that way by the builder, because no trace has ever been found of the stones that originally occupied that place, if such were the fact. So we see this represents how our Lord could not be holden of death. He was raised by the power of God from the death condition, represented by the well. The well, in other words, represents hades, or that condition of death from which there will be a resurrection. This well represents the condition of death from which there will be an awakening or restoration, whereas this subterranean pit represents the condition from which there will be no resurrection.

Now note this point, dear friends, that these figures are all in British inches, not pyramid inches, as stated up at the top of the chart, 1,000 British inches equal 999 pyramid inches, so that in order to reduce British inches to pyramid inches it would be necessary to take one inch from every thousand British inches, and the fractions in proportion to the number of years, etc., representing the fraction of the thousand years.

So from the North, beginning at the grand gallery and measuring back down the first ascending passage to the descending passageway, at the intersecting point, we have a date marked out, so many years before Christ -- 1,545 inches, reducing that to pyramid inches, we have 1543 1/2 years before Christ. And then considering that as a date to measure down to the time of trouble, we find the number of inches to indicate the date 1915 3/4; -- or, in other words, the fall of 1915 as marking the end of the time of trouble: for this North wall of the subterranean, pit represents the end of the great time of trouble, when all the present governments and evil systems -- this present world -- will be completely destroyed.

Now, dear friends, we come to the consideration of the first ascending passage. This represents the law dispensation; it does not represent the Jewish dispensation. We find after the race had proceeded on this downward way for many years, it reached a time when the Lord began to deal with a portion of the world, the Jewish nation, and the law was given to that people through their mediator, Moses. It began to be observed at the exodus of the Jewish people from the land of Egypt.

But now we find that this passageway is an upward way; it is very steep. Prof. Piazza Smith, when measuring the distance from the beginning to the end here, in setting his lamp or candle on the floor, found that it showed an inclination to slip back until it struck what we call the granite plug represented by this red section.

And right here I would say that granite in the great pyramid represents divine things, just as gold used in the tabernacle given to the Jews represented divine things. We find that granite is used nowhere in the pyramid except in the upper chambers and right at the beginning of this first ascending passage. All the rest of the pyramid is composed of lime-stone. So we have a beautiful picture of how the Jews, when the law was presented to them at the hands of Moses, entered into covenant relations with God and said they would keep all the conditions of that law covenant. They said, why all these things will we do. But, poor Jews, they thought they could comply with the law, keeping it fully, but they did not realize their fallen, imperfect condition, and that it was impossible for them to observe the law satisfactorily, because the perfect law of God requires the full measure of a perfect man's ability to fulfill. And so through that long period of time in which the Lord was dealing with that race, we find there was not a single member of the Jewish race who obtained life by the keeping of the law, although it was promised to them that if they would keep the law they would obtain life by it. The law is represented by this granite plug, granite being an emblem of divine things. And the Jews, as they started to come up over this first ascending passage, found something to hinder and block the way -- this granite plug.

Now then, dear friends, the Jews were typically justified year by year through the sacrifices which they made -- not actually justified, but typically justified. The Apostle tells us that the blood of bulls and goats could by no means take away sin, and so they are represented as making progress up over this first ascending passageway. It is only four feet high, about the same height as the descending passage, and this would represent how these Jews were groaning in bondage and servitude to the law, endeavoring to comply with the law, endeavoring to keep the law, and were not able to do so; they were in bondage to it. And it is an upward way; there was no railing, or ramp stones, provided in this first ascending passage; they did not have the exceeding great and precious promises that are given unto the Church, unto the Israelites of God, that are represented up in the grand gallery. The Jewish age being symbolized by the first ascending passage, we find there are three or four different lines of measurements given or marked out in this first ascending passageway that represent important periods or developments in the history of that race. As we have found in our study of the Scriptures, the period of the Jews, or the law dispensation, is clearly indicated. Well when did the law begin? At what year? It began with the exodus from Egypt, and the date is indicated in the pyramid by extending this granite plug downward, by placing the upper end down to where the lower end is now, and then taking the complete measurement from here up to the well, -- up to the time of the death of our dear Redeemer, -- the law age, the law dispensation, beginning with the law, and coming to an end at the death of Christ, when He nailed the law to the cross. And so the exact number of inches correspond with the exact number of years indicated in the Scriptures as being the length of the law age.

Now then, there are three other particular points or periods of time that are mentioned in the history of the Jewish age; and these periods are marked out in this first ascending passageway by three great transverse plates of stone. The ordinary masonry work composing the ceiling and

floor of the first ascending passageway is the regular tier upon tier of stonework, but when we come to these transverse plates of stone, we find the ceiling and walls and floor are all one piece -- not several stones rising up and around, but all one stone; and that the ascending passageway is tunneled right through the great stone, and so they are specially, marked out. Now when we come to measure the distance from this first transverse plate of stone up to the end of the passageway, we find it gives the number of years that indicate a very important point in the history of the Jewish nation. In other words, the special time of favor spoken of by the prophet Daniel is here symbolized in the great pyramid, the time of 490 years, the 70 weeks of special favor that were marked out for that nation. In a prophetic sense a day stands for a year, and seventy weeks, or seventy times seven, would be 490 years. Now when did that period of favor begin? It began with the proclamation given to Nehemiah to rebuild the walls of the city of Jerusalem, and that date is marked in Bible chronology as the year 454 B. C. When did these seventy weeks of favor end? Dear friends, the seventy weeks, or the 490 years, of favor came to an end three and one-half years after the death of our Lord, when the favor that had been confined exclusively to the Jewish nation was turned to the Gentiles. You remember the prophet Daniel tells us that the Messiah would be cut off in the midst of that seventieth week of favor, which began with the anointing of our Lord, and in the midst of the week our dear Redeemer was crucified, and at the end of that week Cornelius, the first Gentile convert, was grafted in and accepted as a member of the Body of Christ. And this is well represented here by the number of inches from this transverse plate of stone, 385 inches up over to the mouth of the well and then off to one side where it is indicated in the pyramid that the gospel of special favor was turned aside from the Jews to the Gentiles.

I would call your attention to this enlarged section of the chart. This represents the beginning of the grand gallery, and we will just suppose we are standing at a point where we are looking up the grand gallery. This grand gallery is seven times the height of the first ascending passage, and we find represented here the well. The well was not located right in the center of the floor, but it was off to one side. This shows how the well was located off to the Western, right-hand side, as you go up; but it was right at the beginning of the grand gallery so that none could go up that way without first recognizing the existence of the well. Now we measure up here 385 inches to the beginning of the grand gallery, and we find from that point over to the mouth of the well, as represented in this larger section, representing this point, there are 23 1/4 inches more; and the well being 28 inches square, half of that would be 14 inches. So we come over to the center of the well, and then journey over here to the opening, 21 inches, and then down 27 inches, then over 20 inches on a line with the West wall of the grand gallery, and as the grand gallery represents the gospel favor of the Lord, you can readily see how the Jews on their way to the "hades" condition, when their nation went into death at the destruction of Jerusalem, reached a point when they passed from under the gospel favor -- they passed outside of it, the favor was no longer confined to them; and we find in adding the number of inches all together, it gives us the exact number of inches that correspond with the number of years of the special period of favor, or 490 years.

Then again, if that date marks the beginning of the seventy weeks of favor, it also marks out another very important period of time. And what was that other period of time that had its beginning at the same time when the commission was given to Nehemiah to rebuild the wall? It began, dear friends, the 2,300 days, or 2,300 years, to the cleansing of the sanctuary.

Brother Morton Edgar, of Scotland, who discovered this time feature in the great pyramid, wrote me a letter and told me how the thought was suggested to his mind, that as the seventy weeks of favor were marked out, it would be reasonable that the 2,300 days should be indicated in the pyramid, because they both had their beginning at the same time. And in considering the matter he saw very readily that to measure from this first transverse plate of stone all the way up to the King's chamber, which represents the Sanctuary, the Church (the King's chamber is the Sanctuary in the Pyramid), there would be too many inches altogether; the distance was too great; and in pondering over the matter, he came to the conclusion that by the means of trigonometry, dropping a line from the North wall of the King's chamber perpendicularly, and then drawing a line from this first transverse plate of stone over to where it would intersect this perpendicular line, he would find the number of years. When he came to work out the problem by means of trigonometry, he obtained 2302 1-3 British inches. Now we are to take off one inch from every thousand, and that means we would take off 2 and 1-3 inches to reduce the British inches to pyramid inches (it being the pyramid inches that indicate the years) and so we have the 2,300 days to the cleansing of the sanctuary.

I would here remark that all of these time features and points indicated in the pyramid seem to have a double corroboration, so as to prove conclusively that this is not conjecture, or coincidence, or guess-work, but that we are justified in accepting the testimony of the pyramid as corroborating the Word of our Heavenly Father. As we have just seen, this indicates the two lines of time prophecy, which are fully borne out in these measurements.

Now we come to the consideration of another important period in the law dispensation. You will re-member the points or dates all have to do with or are embraced in the law dispensation, because they are marked out in this first ascending passageway which represents that. This second transverse plate of stone, measuring from that up the first ascending passage-way, gives us 625 1/4 British inches; now reducing this number to pyramid inches gives us the last jubilee year observed by the Jewish people, for it was 625 years B. C. that the last jubilee was kept by the Jews.

And then, dear friends, coming down to the third transverse plate of stone, we find another line of prophetic testimony marked out. Measuring from this third transverse plate of stone on up and over into the well, clear over to this point, it gives us the number of inches to correspond with the number of years that elapsed from the time when the kingdom of Israel began to the time when it ceased to exist as a kingdom. When did the kingdom of Israel begin? Many have thought the kingdom of Israel had its beginning with King Saul, but that kingdom began when the Jewish nation entered into their own land. The Lord was recognized as their King, and He appointed judges to administer the affairs of the nation for a long period of time, and you remember when they rejected the last one of these judges, the Lord said they had not rejected Samuel to rule over them, but that they had rejected Himself as ruler or King; so this clearly indicates that the kingdom of Israel began at the time when they entered into their own land, which was in the year 1575 B. C. Now, when did that kingdom come to an end? It came to an end with the overthrow of Zedekiah. He was the last king of Israel. He was taken captive in the year 606 B. C.



Now, then, from the time the kingdom of Israel began until the time it was overthrown at the dethronement of Zedekiah, the number of years between these two periods is represented in the great pyramid in the number of inches from this point, measuring up to the well, and considering all these measurements over to this point (indicating) and the number of inches coincides exactly with the number of years that elapsed in that period of time.

Now the nation of Israel went into the "hades" condition. That nation is to be restored some time. In what condition would it be restored? Would the kingdom be restored in a perfect condition, or would it be restored in that condition in which it went into hades, or the death state?

The well representing the death of our Lord, the mouth of which is slightly above the floor surface of this passage-way leading to what is called the Queen's Chamber, represents the plane of human perfection. Our Lord was on that plane as a perfect man when He went into death. Now the Jews went down into hades. Will they come out on the perfect plane, or will they come out on the depraved plane? We find they would come out on the depraved plane, represented by the descending passageway, as indicated by the lower opening of the well. And so considering that point as indicating the time when the nation of Israel was regarded as the kingdom to the time when it would be restored, the full number of years is indicated in the pyramid in this way: The distance would be too great to come down the first ascending passage-way, and then down the descending passageway to the mouth of the well, and Brother Edgar in considering the matter used the method of trigonometry again; running a line horizontally over to a point that was perpendicular over the center of the well, and then dropping a line down to the well and getting the number of inches, it would indicate the number of years from the time of the beginning of the kingdom of Israel to the time when it would be restored. In other words, it indicates the date 1915 when the kingdom will be restored to Israel.

Now, dark friends, we come up to the grand gallery and the horizontal passageway over to the Queen's Chamber. The upper passageway indicates the way to life and immortality. Perfect human life is represented by the Queen's chamber, and immortality is represented in the King's chamber. As we have just pointed out, all the surroundings of the King's chamber is granite, and granite indicates divine things, or conditions. So in all these conditions would be divine or spiritual beings. The only way whereby it would be possible to enter on the way to life and immortality was closed up for a long time. The Apostle tells us that the way was opened up when he said our Lord Jesus brought life and immortality to light through the gospel.

Well, now, let us consider again this descending passageway as representing the world on the downward course. There is no way to get up into the upper passages, unless we were to go up into the ascending passageway, or up the well. We find that the first ascending passageway is blocked by the granite plug. The Jews thought to go up that way and could not, and if they could not, with all the assistance rendered them, surely none of the world' could. Now then, how about the well? Originally the well was closed up at the upper point; it was sealed up so that it would be impossible to get up into the upper passage unless the way was opened up, and this is represented by the appearance of an explosion. Our Lord, by His death and resurrection, opened up the way to life, and to immortality.

Now, as we examine this passageway, we find the floor very uneven, seeming to indicate, in the language of the pyramid, that there were no time measurements recorded there. It is too uneven; you could not get an accurate measurement; but, dear friends, in another way it indicates the whole history of the race from the beginning down to the end. We find that for the first six-sevenths of the distance the height of this passage is less than four feet, and this would represent the condition of the world still groaning under the oppression of sin by the Adversary, the god of this world, Satan. Now then we are looking at this passageway, not from the same point we viewed the matter over here. This represented the world going into destruction, but this represents the view as looking at the race from the standpoint from which the Heavenly Father would view it, and the fact that the well, which represents our dear Redeemer, is at the beginning of that way would indicate that He is the Lamb of God slain from the foundation of the world; and so, from that standpoint, the world of mankind is not going on to destruction, but they are going on to the condition represented by the Queen's chamber and the enlargement of this passageway. We find that after having passed over six-sevenths of the distance, the remaining seventh is a step of 21 inches, so that the height of the passageway would be five feet, eight and one-half inches, just the height of an average man. How beautifully this symbolizes the condition of the world for six thousand years, or for six-sevenths of the distance, groaning and bending under the weight of sin. Now this is all in darkness, and they come to a point where they go over the step, and in the darkness go down 21 inches. That represents the great time of trouble. If any of you have ever been walking along a hallway in the dark, not knowing where you were going, and suddenly you stepped off and fell down the step you were badly shaken up and possibly bruised. That will be the circumstance in connection with the time of trouble in which the world will be involved. The whole world will be greatly shaken up. The Apostle speaks of it, and likens it to a great earth-quake, and states that all things that can be shaken will be removed, and the things that cannot be shaken will remain. And so the world will go into the time of trouble; but when they struggle to their feet again, they will find they enjoy greater freedom and liberty. Now they are released from the burden of sin and oppression of the great Adversary. They can stand upright. Now then they can begin to rejoice in the liberty of the sons of God. If any of the race imagine they are six feet tall, and that they are somebody, they will bump their heads on the roof which is five feet eight and a half inches from the floor. The Millennial age is a great leveling time, bringing the race to a proper realization of its condition; and it was designed to lead the world on to the condition represented by the Queen's chamber – full perfection, full deliverance from all sin and imperfection.

There are seven sides to the Queen's chamber; -- two parts of the ceiling, the four walls, and the floor; and seven in the Scriptures, as we all know, is the symbol for completeness, or perfection. So that represents the perfect condition of the world as it will be at the end of the thousand years of the millennial reign of our Lord, after the final testings that will close that thousand-year period.

We come now to a consideration of the grand gallery, which is seven times the height of the first ascending passage, which was four feet high, the grand gallery being twenty-eight feet high, and to my understanding represents the fullness and completion of the blessing of the Abrahamic covenant that would come to those who would go up over the grand gallery condition. ,

Imagine the appreciation of those Jews, who, coming up out of the first ascending passage, would now enter into the grand gallery condition. Now they could stand upright. It is a beautiful way to walk in, but it is a very narrow way, represented here by this enlarged section, twenty-eight feet high and only seven feet wide at this point, the lower section along the floor, but we find on each side of the grand gallery ramp stones, or stone railing, projecting out about twenty inches. So that would make the floor-space still narrower, and there would be but room or space for two people to walk abreast up the grand gallery. This beautifully represents how we are to walk in the companionship of our Lord Jesus Christ -- "My Lord and I." So those Jews who were delivered from the bondage of the law, how it must have rejoiced their hearts when they came out into the condition where they could appreciate the liberty that belongs to the children of God. You remember our dear Redeemer came unto His own, but His own received Him not, but to as many as received Him, to them gave He liberty, or power, to become the sons of God.

Now think of the favorable conditions represented in this grand gallery! Here we have this railing, but the way is still up. It means overcoming, it means a toil-some way; it is a narrow-way, but by availing ourselves of the help that our Lord has provided, and has beautifully represented in this grand gallery, we are able to make progress, and to go up to the conditions represented by these upper granite chambers. These two railings, one on each side, to my mind suggest the precious promises of our Lord. We know something about these promises. We were talking about them here the other day in our testimony meeting, when Bro. Van Amburgh was here. The Apostle Peter says, "Exceeding great and precious promises have been given unto us, that by these we might become partakers of the divine nature." With you and I it is a very important matter that we lay firm hold on these promises of our Lord, in order to assist us in making progress onward and upward over the narrow way over which our dear Redeemer walked. And as we go onward and upward, we come near to the grand gallery, and we find there is a step projecting quite a distance into the grand gallery, represented here in this larger section by these lines; it projects sixty-one inches from the South wall of the grand gallery. Now we have been looking at the grand gallery as representing the individual experiences of the members of the Church of Christ. Let us look at it as representing the high calling. Let us look at it now from the collective standpoint, as it were, representing the course all the way along from the beginning of the high calling, which began with the birth of our Lord -- the North wall of the grand gallery. Our Lord was called from His birth. But now as we come to the end of the high calling, we encounter this great step, and this to my mind suggests the thought that in the closing days in the experience of the Church there will be a special time of trial and testing come upon those who are endeavoring to enter into the King's chamber. Dear friends, take the individual experience of our dear Redeemer; we know that while in the Garden of Gethsemane He experienced, as it were, the supreme trial and test of all His experience. There He was tried so severely, He prayed to the Father that if it were possible the cup of suffering might be removed, yet he said, "Not my will be done, but thine, O Lord." So, dear friends, we understand that would represent the experience of the members of the body, when in the closing days of their individual experiences they would be called upon to go through with the final or supreme test. And what will that test be? Along what line? It will be along the line of complete submission to God's will -- a complete humbling under His mighty hand. Dear friends, may we avail ourselves of the grace of God that is provided for us at this time to grow stronger in the Lord and in the power of His might, that we may be enabled to pass successfully the final trial and testing. Now while this is an individual matter. During the whole history of the Church, the Scriptures indicate that in the

last days of her experience there will be a time of fiery trial and testing, and the Scripture statement is, who shall be able to stand? Only those who have put on the whole armor of God, who are trusting in the Lord. endeavoring to do His will, humbling themselves under the mighty hand of God.

Now coming to the close of the conditions represented by the grand gallery, the close of the high calling, we find that the experiences of the Church are represented likewise in the ante-chamber and the king's chamber. The ante-chamber and King's chamber of the pyramid represent exactly the same conditions as are outlined by the apartments of the tabernacle, and where the gold represents one thing in the tabernacle, the divine condition, so the granite represents the divine condition in the King's chamber. The ante-chamber is formed something after the order of a school room; it has something of that appearance. and this represents how we are in the school of Christ, guided by the holy spirit. and learning lessons of our heavenly Father's ways by the experiences of life. But in order to get into that ante-chamber, it is necessary that you enter through that passage way, and there is a projection extending from the upper portion down to within four feet of the floor, represented in these lines (indicating). In order to get into the ante-chamber, it is necessary to bow very low in order to come up inside the chamber. Now this to my mind suggests the sacrificing and putting to death of the human will. It is necessary before we can be taught of the Lord that we humble ourselves, and put away our own wills, desires and ambitions.

But then there is another condition to comply with before we are actually and fully in the ante-chamber; and that is represented by what is called the granite leaf. This extends to within four feet of the floor. After putting to death the human will, coming up to the other side of this projection it is necessary for us to humble ourselves once more in accepting the Lord's will. The divine will is represented in this projection. You know it is possible for one to give up his own will and accept the will of someone else, but that is not the Lord's arrangement; that is not what He desires. In order to be instructed of Him, it is necessary that we accept His will, and be guided by Him. So having accepted the Father's will, we are fully in the ante-chamber, and are recognized as spiritual sons of God. You will notice that the lime stone is represented by the white here, and the divine, or spiritual condition is represented by the red shading; that the granite floor begins under the granite leaf, and this shows how that when we have accepted the will of the Father as our will, we are no longer human beings -- old things have passed away, all things have become new; we have a new standing before the Lord; we are new creatures in Christ Jesus. But you will note this particular feature: that the granite flooring is directly perpendicular over the North wall of the subterranean pit; the bottomless pit. as we have pointed out, representing the second death, absolute destruction from which there would be no resurrection or restoration, so this seems to indicate that those who have been be-gotten to the spiritual condition, those who are new creatures in Christ, if they fall away, if they deny the Lord. if they are rejected, it means the second condition for all such.

Now then, going on, we make progress towards the King's chamber. We find there is another low passage-way to pass through before we actually enter into the conditions represented by the King's chamber. The King's chamber is entirely of granite. It is thirty-four feet long, seventeen feet wide, and nineteen feet high -- a very honorable chamber, and all the conditions there, as represented in the granite, are divine conditions -- actually so. In order to attain to the glory,

honor and immortality reserved for the people of God, it is necessary to go through this low passageway, scarcely four feet high. That low passageway represents the actual death of those who have given their all to the Lord, and have consecrated themselves to walk in the footsteps of the Master. You see this represents exactly the same condition as is represented in the tabernacle. The door into the tabernacle represented the consecrated and spirit-begotten condition, and the second veil represented the actual death and entrance into the holy of holies -- into heaven itself.

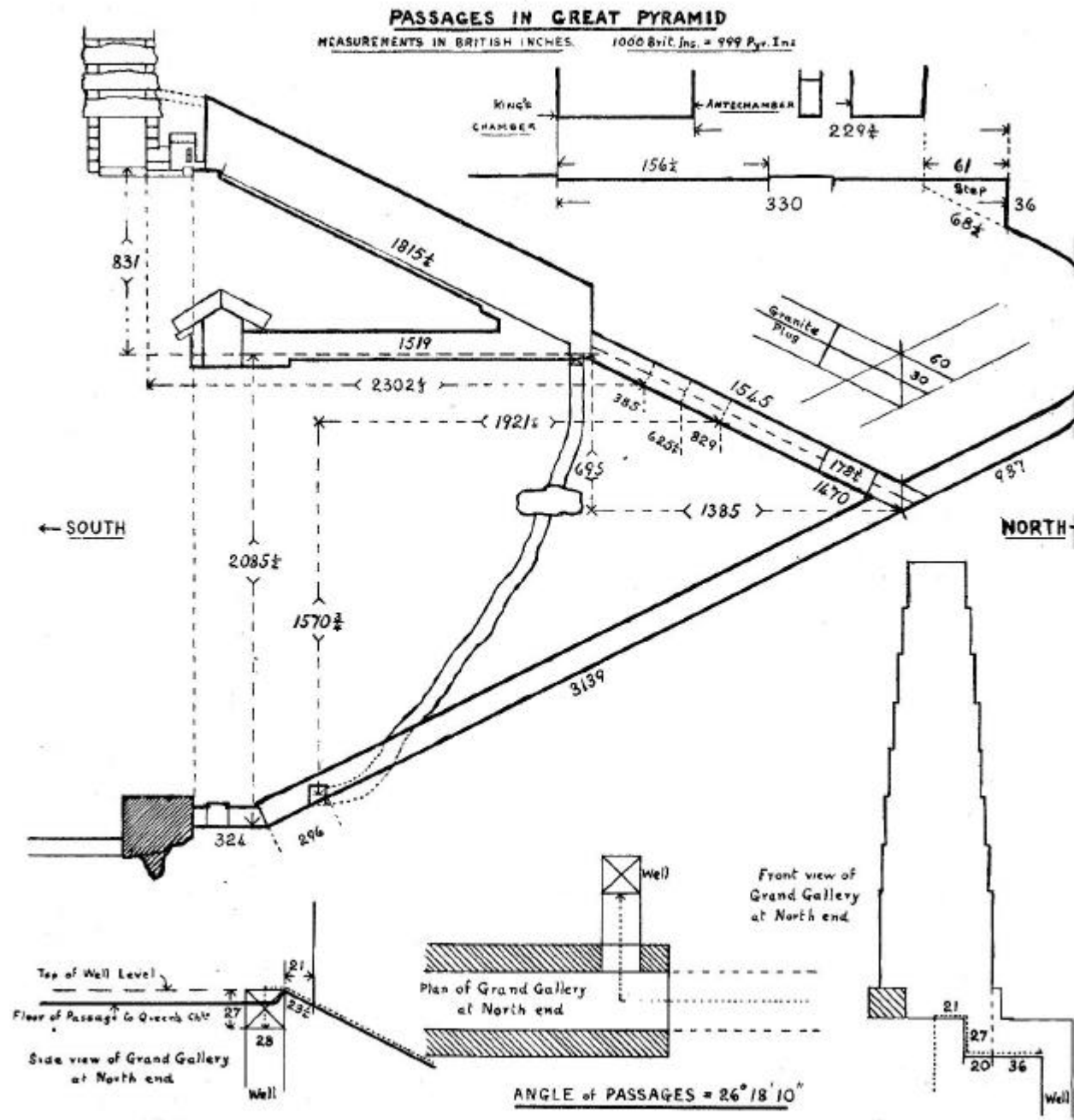

Now, in closing I will just point out that the symbolism of the grand gallery, as I have endeavored to explain to you, is further proved or attested by the measurements. As we said, the grand gallery, the high calling condition, began with the birth of our Lord Jesus. And measuring from the north wall on up to the bottom of the step we have 1815 1/4 British inches. Now there are three sets of measurements outlined or indicated by this step. If we measure directly up

through, omitting and ignoring the step, a distance of sixty-eight inches, adding that to 1815 1/4 British inches, we have 1883 1/4 British Inches. Well now reducing that to pyramid inches, we have 1881. The date 1881, as outlined in Bible chronology. represents the closing of the high calling. Now the Lord's call is restricted, and as a vacancy may occur in the elect class, as some lose their crowns, others are invited in, but the general call ceased in 1881. Another measurement which is indicated by coming up to the step, and omitting the face of the riser, the 36 inches, beginning at the top of the step and measuring over to the south wall, sixty-one inches, and reducing that to pyramid inches gives us the date 1874 -- marking out a very important period of time.

But now, dear friends, we have one more measurement. Measuring along from the beginning at the grand gallery on up to the step, and up the face of the step, and along over the top to the South wall, and adding all of these figures together, and reducing the number to pyramid inches, it gives us the date 1910. Now, dear friends, we have not as yet found any particular significance in the Bible to that date; so far as we know it is not marked out in any way, but to our understanding it suggests the closing of the door, or closing of all opportunity of entering into the high calling with the privilege of making our calling and election sure, and of entering into the glorious condition of immortality. Viewing it from this standpoint, the time is now short in which we would have opportunity to make our calling and election sure. Now this is offered merely as a suggestion, and not as something dogmatic.

So, dear friends, by these measurements, we have the symbolisms, or the lessons of the pyramid, in harmony with the chronology of the Scriptures, attesting, corroborating, and confirming the teachings of our Heavenly Father's Word, and for my part I have learned to love this great witness which our Heavenly Father was so kind as to provide for us. And I believe it is a special mark of His love and favor in bringing us to an understanding of these matters, that our faith might be increased, and that we might have stronger foundation for our faith; and I think the more we avail ourselves of these helps, the more reverent our love for all the Father's provisions for our needs, the stronger we grow, the more appreciative of his goodness, and the more pleasing in His sight. And my earnest desire this after-noon has been to point out some of the features of this pyramid, that you might study into the matter more fully, and derive increasing joy, and peace, and comfort, in having the assurance that these things are true, that the time is short, that there have been no mistakes regarding the chronology of the Scriptures. In a recent issue of the Watch Tower a query was made by one of the brethren to this effect: Are we justified in accepting the lines of chronology as given in the Scriptures. and presented in the Dawns, as positive knowledge? And our dear pastor pointed out that we are not walking by sight and as actual positive knowledge, but are walking by faith; but at the same time, in view of the fulfillment of prophecy, and the testimony of this great witness of the Lord, we are justified in saying that there is not a shadow of doubt but that the Bible chronology of our Heavenly Father's Word, as presented in the Dawns, is true. Amen.

## 8 P. M. -- Discourse

by Brother W. J. Thorn, of Boston, Mass.

### Topic: "Full Assurance of Faith."

A condensed Report of Brother Thorn's Discourse follows :

FAITH is the most important thing in the life of a Christian; and love is not possible without it. Faith is the foundation upon which the true Christian builds character like the pattern of our Lord. The apostle Paul says: "Without faith it is impossible to please God." Why did not Paul



say, "Without love it is impossible to please God"? Because faith is the foundation. It is necessary at the start and all along our journey. In Rom. 11:20 the apostle says, "Because of unbelief they (the Jews) were cast off. But thou (believing Gentile) standest by faith." And again in 2 Corinthians 1:24, "By faith ye stand." Secondly, we walk by faith along the narrow way. 2 Corinthians 5:7, "We walk by faith and not by sight." Thirdly, we live by faith. Gal. 2:20, "I am crucified with Christ: nevertheless I live; yet not I, but Christ liveth in me: and the life which I now live in the flesh I live by faith of the Son of God, who loved me and gave Himself for me." Fourthly, we can be overcomers only through faith. 1 John 5:4, "This is the victory that overcometh the world, even your faith."

But while faith is of such importance to the Christian, yet he must have something else, too, for, as Paul says, "Though I have all faith so that I could remove mountains, and have not love, I am nothing." Faith is the foundation upon which we must build our character. As Peter says, "Besides this, giving all diligence, add to your faith virtue: and to virtue knowledge: and to knowledge temperance: and to temperance patience: and to patience godliness: and to godliness brotherly love: and to brotherly love, love. For if these things be in you and abound, they make you that ye shall neither be barren nor unfruitful in the knowledge of our Lord Jesus Christ." (2 Peter 1:5-8.)

What is faith without which it is impossible to please God? In Heb. 11:1 we have the answer: "Faith is the basis of things hoped for, the conviction of things unseen." (Diaglott.)

How do we get faith, or how does faith come? The apostle answers in Rom. 10:17: "Faith cometh by hearing and hearing by the word of God." "How firm a foundation, ye saints of the Lord, is laid for your faith in His excellent Word."

### Full Assurance of Faith.

The apostle in Heb. 10:19-23 says: "Having, there-fore, brethren, boldness to enter into the holiest by the blood of Jesus, by a new and living way which He hath consecrated for us, through the veil, that is to say, His flesh; and having an High Priest over the house of God: let us draw near with a true heart in full assurance of faith, having our hearts sprinkled from an evil conscience, and our bodies washed with pure water. Let us hold fast the profession of our faith

without wavering, for he is faithful that promised." God, therefore, not only requires faith of us, but gives us the means necessary to obtain this "precious faith." How few of the Lord's professing people are able to give a satisfactory answer to the question, Why I Am a Methodist, or Why I Am a Baptist? etc. About all they can say, "We are here because we are here." Again there are others of the Lord's people who have some faith but not a full assurance of faith, a conviction of things unseen. Their standpoint expressed in words is

**""Tis a point I long to know."**

They are amazed when they meet any one who speaks with assurance as to his faith, and declares he knows in whom he has believed, and is fully persuaded in his own mind. What is the difference between these two classes? The one class, filled with fear and foreboding by the precepts and teaching of men whose teachings are not founded upon God's word, have practically no basis for faith, nothing to build on. They hope everything is all right with them, but they fear that all is not well, and because of their fear they are in torment. If, according to their supposition, we are immortal beings, why then do we hope for immortality? Hope that is seen (or realized) is not hope, for what a man seeth (or possesseth) why doth he yet hope for it? But if we hope for that we see not (do not possess) then do we with patience wait for it." Rom. 8:24, 25.

The other class have their faith based or founded upon God's Word. They have the Scriptural assurance from God's Word that (Rom. 8:1), "There is therefore no condemnation to them that are in Christ Jesus, who walk not after the flesh, but after the Spirit." And that (Rom. 8:14) "As many as are led by the Spirit, they are the sons of God." And (verse 16) "The Spirit itself beareth witness with our Spirit, that we are the children of God." Into such a heart the love of God enters and abides, and it casts out fear and torment, and peace and joy reign within.

It would be very displeasing to the Lord for such to at any time doubt their sonship. "Beloved, now are we the sons of God, and it doth not yet appear what we shall be: but we know that, when He shall appear, we shall be like Him; for we shall see Him as He is."

There are some things that we do not know yet. Never having seen God, we do not know what He is like. We do not know what Jesus is like. We are unable to describe any Spirit being, therefore we know not what we shall be like. But there are some things we do know. We know that when He shall appear we shall be like Him. John says of this class, "Ye have an anointing from the Holy One and ye all know it." (1 John 2:20, Diaglott.) And in I Thess. 5:1 we read: "But of the times and seasons, brethren, ye have no need that I write unto you, for yourselves know perfectly that the day of the Lord so cometh as a thief in the 'night." And your Master's own words are, "Ye shall know the truth, and the truth shall make you free."

But faith alone will never gain for us the promised reward. "Faith without works is dead." We must also have patience. The Apostle, in Heb. 6:12, shows us that we must get to work: "That ye be not slothful, but followers of them who through faith and patience inherit the promises." Well did our Lord know how trembling would be our faith, and we might express it as follows:



"Is it for me, dear Lord, Thy glory and Thy rest?  
For me so poor and humble, ah! shall I then be blest?  
Is it for me to see Thee in all Thy glorious grace,  
And gaze in endless rapture on Thy beloved face?"

And hear what God in mercy hath said to us (Heb. 6:16-20): "For men verily swear by the greater; and an oath for confirmation is to them the end of all strife. Wherein God, willing more abundantly to shew unto the heirs of promise the immutability of His counsel, confirmed it by an oath: that by two immutable things, in which it is impossible for God to lie, we might have strong consolation, who have fled for refuge to lay hold upon the hope set before us: which hope we have as an anchor of the soul, both sure and steadfast and which entereth into that within the veil; whither the forerunner is for us entered, even Jesus, made an High Priest forever after the order of Melchisdec."

If we have the proper faith in God, we are compelled to believe that all things work together for our good. If we are truly His children, and are properly exercised by what God sees fit to send upon us, we would not dare to believe anything to the contrary. And consequently we permit God to choose for us whatever He sees is best; for we know that He knows us, and loves us, and careth for us.

To be where God wants us to be, is to be contented and happy And to realize God's presence and smile and blessing there, is to be in the sweetest place there is on earth.

"Content with beholding His face,  
My all to His pleasure resigned;  
No changes of season or place  
Can make any change in my mind.

"While blessed with a sense of His love,  
A palace a toy would appear;  
And prisons would palaces prove  
If Jesus still went with me there."

**SATURDAY, OCTOBER. 5.**  
**9:30 A. M. -- Praise and Testimony Meeting.**

THE friends were asked to give a verse of Scripture along with their name and testimony.

Bro. Gibbs: "Our Rock is not as their rock, even themselves being the judges." Bible Christians, greetings to all.

C. D. Wright, Boaz, Ala.: "Surely goodness and mercy has followed me all the days of my life." Brethren, I saw the goodness and mercy of God something like twenty-five years ago. I was a missionary Baptist minister; I was in darkness and was praying that the Lord would give me light. I wanted more light and God worked the matter about that I came into possession of the first volume of the Dawn, the Plan of the Ages, and it gave me more light and comfort and joy. I thought everybody in the world surely would accept it if they could only hear it. I had an appointment about a week off and it seemed so long, because I wanted to tell them of the darkness and the light; but to my astonishment, they began to kick and call me an old crazy crank. The truth has been growing brighter and brighter with me and will continue until the perfect day.

Bro. La Ferry: I was a Baptist minister myself, and I too thought everybody would come into the truth if it was only presented to them. I thought I would convert the whole of Georgia and then Tennessee; I thought it was a world-wide work and would take only six months to do it if I could only get a lot of my friends to help, but my friends were my worst opponents. I can't understand why I waited so long before I found the Dawns. When I first received the first volume, I had only read a part of it and I began to spread the truth. I want to lay down my life in the Harvest; I would like to lay it down in a week if I could be with the Lord.

Bro. and Sr. Wiley: We are glad to be able to say that we know John 3:16 is true. The thought came to me yesterday, what a glorious thing it is to know that we have been beheaded, and that bye and bye we will reign with our King. Kings and queens take care of their relations, and how the Lord takes care of His children! We have a loving God who has made pro-vision for one and all.

A Sister: "Blessed are they who hunger and thirst after righteousness, for they shall be filled." I have read all the books, but I am going back to read them all over again.

A Sister: "There has not failed one word of all His good promises." Surely the Lord is fulfilling all of His promises with us at this Convention. I praise Him that I am one of His children.

A Brother: This promise of my Blessed Savior impresses me, "My grace is sufficient for thee." I am a little baby in Christ. I have just finished reading the six volumes of Dawn and I can testify to the grace of God and, I want to express my gratitude to our Father and to Bro. Russell and to all the dear brothers and sisters at this Convention. The first volume was put into my grip by my wife, who said that the brother who gave it to her was a good man anyway. I read It and then the next, and the next, etc.

A Brother: I am not serving a God of hate, but a God of love. I have been in the truth for only about three months. I read only half-way through when I realized that I had found the truth and it was what I had been looking for.

A Brother: Just to hear the testimonies this morning is worth more than my transportation to this Convention.

A Brother: A preacher once said, that one thing he noticed was when anyone got this doctrine of Millennial Dawn, they got it very bad. From the expressions heard this morning, there are a good many here that have it pretty bad, and I am one of them.

Bro. Ellis: "Be not conformed to this world, but be ye transformed by the renewing of your mind that ye may prove what is that good and acceptable and perfect will of God." When we realize the shortness of the time, I think we will all be willing to be very patient and humble and submissive to God while guiding and overruling all of our experiences so as to develop this character-likeness of our dear Lord. I realize that I come very short, but I am trusting in the merits of my dear Redeemer. I certainly hope to meet with you beyond the veil and to be associated with you in blessing all the families of the earth. When I read my Heavenly Manna, I offer a special prayer for those names who appear that day.

Bro. Murray: "Thou wilt keep him in perfect peace whose mind is stayed on Thee." I have recently passed through a very severe trial, the death of my beloved and only child, and I do not know what I would do without this truth. I have no one in my family who is in the truth; but the principal contest I have is within my own heart, -- there is the battle-ground. Thank God I expect through the merits of Jesus Christ to overcome.

A Sister: This is my eighth Convention, and I have never had the courage to testify before. I want to say, "The Lord is my light and my salvation, the Lord is the strength of my life." All the dear friends look alike, even the colored brethren; they all look like us, too; they have the same smile.

A Brother: I have been to three Conventions, but never testified. I thought it was Satan that kept me down, but from Brother Draper's discourse, I learned it was not Satan, but the old man. I therefore intend to resist the old man and treat him like the devil.

A Brother: I am Brother O. K. Jones of Chicago. "By His grace we are saved." I wish to say by His providing a way, I have been able to come to this Convention. Financially, I was not able to attend. In His name I am here, thank the Lord. I thank my kind and Heavenly Father for His loving kindness that I am able to meet you all. I also thank my Heavenly Father for using the one in the way He is using this one, that I might be able to attend this Convention. I trust this one whom I know not, shall receive a blessing. I thank Him also for giving me a peep at that great store-house (Bible House). While I have had trials, as have many of you, I stumbled, yet not cast down. His grace has been sufficient, and by His grace I am still in the race. I will say that the prayers of a righteous man availeth much. I ask that you remember me at the Throne of Grace, that I may reign with Him a thousand years. Blessed be the name of the Lord."

A Sister: "I will never leave thee nor forsake thee." We know that if we trust the Lord fully, He will never leave nor forsake us."

A Sister: I thought the salvation of the world depended upon me; that it rested upon my shoulders. At one time I was sent with my sister to a missionary convention, but instead of having more light, the darkness increased. I was away from home at school, but my health failed and I had to go home, but there I got the truth through my brother.

A Sister: I was told, don't go to Norfolk and make a "monkey" of yourself, for I understand you people jump up and down like the Quakers of old. I am glad that I came, for I received a great blessing.

Bro. Kuesthart: Seventeen years ago this month through the grace of the Lord I came out of the Lutheran Church after reading the first volume of Millennial Dawn. I am not alone, as many of the dear friends are; my dear wife and all the children are with me. At first the children thought it strange not to attend Sunday school and not to attend a Christmas exercise, but we provided for them at home, and as a result they consecrated one after another. Right here I wish to impress this point upon the minds of the friends. Do you take the proper care of your children? In many families both the father and mother belong to the truth, yet allow their children to attend the nominal Sunday school. Even if our children do not come to the point of consecration, we should try to give them a full understanding of justification, that they may know the truth, and when the time comes, when the Lord has something for them, they will be in the best possible condition to receive it.

Bro. Williamson: Our dear Brother Holmes and Brother Munsell desire to take part in this testimony service, but owing to their peculiar condition, they wish to express themselves by pen and I will now read their written testimony:

Our Dearly Beloved Brothers and Sisters: -- We do not want to go back home without giving a testimony at this Convention, but as you all know this awful blow which came to us so suddenly has crushed our hearts of flesh, and although they are bleeding, the heart, or mind of the inner man (the new mind), has a deep peace which passeth all understanding. And we do thank our dear, loving Heavenly Father with all our hearts for this peace which comes from a knowledge of His divine plan, and we are more determined than ever to press on, and bind the Sacrifice tighter upon the altar which stands so close to the veil, which is thinner than we have ever thought. We read in God's precious Word, "Blessed are the pure in heart: for they shall see God." We have full assurance that they have seen His face and have received His kiss, and have also seen the face of their Blessed Lord and Redeemer, and can now indeed tell the story saved by grace.

So, dearly beloved ones, knowing these things, let us press on and do those things which we know are pleasing to our dear, loving Heavenly Father and our Savior and all beyond the veil, having the assurance that "the Father Himself loveth us," and how precious to us is our text for this year, "Set your affection on things above."

We do want to let you all know, especially the dear tired feet members of the Body of Christ who are at the Bible House and in the Pilgrim service, that you can little realize at this time how we

are comforted through your labor of love, and we have peace, even though we have had those taken from us who were more precious to us than a right eye or a right hand or life itself.

Dear Sister Munsell had just written a letter only a short time before she died and headed it with this verse (Mal. 3:17), "And they shall be mine, saith the Lord of Hosts: in that day when I make up my jewels."

And dear Sister Holmes has said many times of late, "How could any one deny the ransom -- how could they? No matter what would happen, I would never do that."

May God bless you all -- all at this Convention and all not able to attend -- is the prayer of both Brother Munsell and myself.

Your brothers in Christ.

Sisters Nation then sang "I shall see Him face to face,"

## 11 A. M. -- Service

opened with Prayer by Brother A. E. Williamson, after which all joined in singing No. 130: "Earnest Watchfulness." This was followed by a Discourse by Brother S. D. Senior, of St. Joseph, Mo., who was introduced by Brother Williamson as follows:

I NOW have much pleasure in introducing to you a dear brother from the middle west, one who has been very faithful and energetic in arranging the details of this Convention, our dear brother, S. D. Senior, who will speak to us on the subject, Gathering and Scattering."

Brother Senior spoke, in substance, as follows:



Brother S. D. Senior.

Dear Friends: "Jesus is head over all things to the Church, which is His' Body." As we are here gathered together as members of His Body, let us bow our heads in silent prayer, asking His guidance that the words that may be spoken may be for our edifying. (All joined in silent prayer.)

We have for our subject, dear friends, one that is of vital interest, we believe, to all that are engaged, in any manner, in running for the mark of the prize of the High Caning, and that are striving to aid in the "harvest" work.

The subject, as announced, is "Gathering and Scattering." We have as a basis for our study Matthew 12:30, "He that is not with me is against me; and he that gathereth not with me scattereth abroad."

Ah! dear friends, if we could only grasp the meaning of these words, and keep them in our hearts daily and hourly, how much they would edify us, and how carefully would we seek to walk with

Him in the narrow way, and strive to carry forth the glad tidings, the harvest message: as He has given it to us, that we may be gathering "with" Him and not scattering.

Let me read our text again to fix it in our memories: "He that is not with me is against me; and he that gathereth not with me scattereth abroad."

Dear friends, we would like first, to bring to all the thought that there will be a "harvest" time, that there will be a time for "gathering," and we would like to consider briefly a few of the things leading up from the sowing, to the harvest.

First, we desire to point out in the Parable of the Sower, how the Gospel has been received clown through this Gospel Age. "In sowing some seed fell: First, by the road, and the birds came and picked them up. Second, and others fell on rocky ground where they had not much soil and immediately vegetated through not having a depth of earth, and when the sun had risen they were scorched, and having no root, they withered. Third, and others fell among thorns: and the thorns choked them. Fourth, but others fell on good ground and yielded increases, some a hundred, some sixty, and some thirty."

Our dear Lord explained this Parable to His disciples -- His learners--He being teacher and we being His pupils, as follows: When any one hears the word of the Kingdom, but considers it not, the evil one comes and snatches away that having been sown in his heart. This explains that which was sown by the road.

That which was sown on rocky ground denotes him who, hearing the word, receives it immediately with joy; yet it having no root in his mind, he retains it only a short time; for when affliction or persecution arises, on account of the word, he instantly stumbles.

That which was sown among thorns, denotes that hearer, in whom the cares of the age and the deceptiveness of riches, chokes the word, and render it unproductive.

But that which was sown on good soil, and produced fruit, some an hundred, some sixty, and some thirty, denotes him who not only hears and considers, but obeys the word. And so we note in this explanation by our Lord that the Gospel, coming in contact with mankind, would divide them into these four classes, according as they heard, considered, and obeyed the word.

The first class came in contact with the Gospel, but gave it no consideration, or considered it of very little importance. The second class received it with joy, but would not stand persecution for the word. The third class was good soil, but they allowed the cares of this evil age and the deceptiveness of riches to crowd out the word so that it would not bring forth the fruitage in their lives. The fourth class heard, considered and obeyed the word, and brought forth fruitage. So it has been down through this Gospel Age from seed sowing to the harvest, to the end of the age, the time in which we now live, with our dear Lord present again as Chief Reaper, and is now bringing forth the Harvest Message, and this harvest message is being sent forth by Him to gather the wheat unto Himself, in the barn condition. And this harvest message is received in like manner as the dear Lord explained the parable, the world of mankind still dividing into these four general classes as they hear, consider, and obey this harvest message. And we who are

watching can see those who are obeying this message being gathered together unto our dear Lord and Head, and can note them bringing forth the fruitage of the spirit in their lives.

Second. We desire to call attention to the parable of the Wheat and Tares, and no doubt, we are all well acquainted with its teachings; it teaches that there will be a harvest and why a gathering time would be necessary, and this is what we desire to show.

You will remember how the wheat and tares were to grow together unto the harvest, and how in the time of harvest He would say to the reapers, Gather ye together first the tares, and bind them in bundles to burn them (as tares, not as human beings), but gather the wheat into my barn. And how our dear Lord soweth the good seed, the children of the Kingdom, begotten by the word of truth, in the field, the world; and while men slept (when the Apostles died) the enemy of the Adversary came and sowed tares, the children of the wicked one, begotten of error, of excitement, of fear, of hopes of worldly advantages, by joining some nominal church, etc., among the wheat -- the children of the Kingdom -- and how the wheat class discovered the imitation wheat class, the tares, and they were told not to gather them up during the age, lest they root up the wheat with them. And they were told to let both grow together until the harvest, the end of the age, and that in time of harvest our dear Lord, present as chief reaper, would say to the reapers, the angels, the messengers, those who have the harvest message and are carrying it. We would like to remark here that we are not the message, but that we are messengers having a message to carry -- the harvest message that will bind the imitation wheat, the tares, into the bundles, the various sects, etc., preparatory for the burning in the great day of trouble, for the uprooting. "Every plant which my Heavenly Father hath not planted shall be uprooted." Matthew 15:13, "And the heavens departed as a scroll when it is rolled together." But the message coming in con-tact with the wheat class would gather it into the barn of separateness from the world; be gathered unto Himself. And in this time of harvest "he that gathereth not with me scatters abroad."

Third. We desire to call attention to the falling away, and how wheat and tares became mixed, and having become mixed, it would be necessary for a harvest time, a time of gathering.

Our Lord spoke a parable of three measures of meal. As we understand this, the three measures of meal refers to all the teachings of the Scriptures that would produce the proper faith, the proper hope, and the proper love which our Heavenly Father would accept and reward. The Adversary, recognizing this, endeavored to destroy these teachings, and when the Apostles fell asleep (died), in due time he formed the Apostate Church, the Roman Catholic System, through which System he gained great power over the three measures of meal provided for God's household, The True Church, and the Adversary proceeded to mix with the three measures of meal the leaven of her impurity. The result was that all the family food, all the Holy Doctrines were contaminated with her false doctrines -- nothing was left pure and clean, as it was handed to us originally by our Lord through the Apostles. "The Faith once delivered to the Saints" was distorted out of semblance to its original simplicity, the Hope set before us in the Gospel was changed to another hope, entirely unlike the original. The Spirit of the Lord -- LOVE -- was perverted to a selfish love of creeds of men and human institutions. And so we see the wheat sown by our dear Lord, begotten "by the word of truth," and the tares sown by the Adversary, begotten by the word of error, growing side by side down through this age until the harvest, the

time of gathering. So that when our dear Lord came in 1874 He found the whole mass of teachings as held forth by the Apostate systems, "mother and daughters," so leavened by false doctrines that He rejected the whole mass in 1878, and from this date on has been calling to Himself from among the various sects and the world of mankind those who are His, the wheat.

We might ask, Why did not our Lord select some sect or human organization and purify it, and use it as the instrument or channel for the gathering?

Looking back at the first harvest, the one at the end of the Jewish Age, we notice our dear Lord did not come as a Pharisee, neither as a Sadducee, but came outside of all sects, and called the Israelite in-deed unto Himself, by using a harvest message then for this purpose. And in the antitype, this harvest, He again comes outside of all sects and worldly organizations. because they are so leavened with the false doctrine of the Adversary, that if any sect was selected and the truth placed in it, the truth would so change their doctrines and practices that it would be truly a new organization. Our dear Lord gave us an illustration on these lines, in the new wine not being placed in old skins (bottles), for there would be no elasticity left in the old skin, and if new wine was placed in one of these old skins, it would ferment and produce a gas, and there being no elasticity in it, it would burst the skin and spill the wine. And so in these various sects there is no elasticity in them that would permit them to conform to the truth, as it is in Christ Jesus our Head. So now the old leavened organizations were rejected. In the year 1878 our dear Lord assumed His authority as King and spewed all these various systems out of His mouth, as unfit to be used by Him in this harvesting. And He is now, as in the first harvest, calling and gathering His consecrated ones out of all sects and organizations unto Himself. You and I are living in this time of gathering, and it is to us that our text has its peculiar force and meaning. Let us read it again, "He that is not with me is against me: and he that GATHERETH NOT WITH ME SCATTERETH ABROAD." And the command is to GATHER my Saints TOGETHER unto Me, those who have covenanted with me by sacrifice. I would like to call attention to the fact that all down through this Gospel Age we were unable to tell who were wheat and who were tares; they were associated together in these various systems, both growing together, until the harvest time. But today, in this gathering time, we are able to distinguish between wheat and tares. We even see the separation of these two classes taking place before our eyes. We ourselves are here assembled together, all of like precious faith, some out of this Sect and some out of that Sect; and not only we in this hall, but no doubt you have some dear ones of like precious faith at home, and I know that I have. Why is it that we see this separation taking place? It is because the harvest is on, the gathering is in progress. Down through the Age we were not able to assemble our-selves together, for some were in this Sect and some in that, but now, when the dear Lord is gathering His elect from the four winds of Heaven, from all parts of the nominal systems, we can now obey, Hebrews 10:25, and not forsake the assembling of ourselves together, as the manner of some is, and we can exhort one another to faithfulness, because we know who are our brethren. And we can do this so much the more, for we do see the day approaching. Ah! dear friends, those who are neglecting the assembling of them-selves together are missing blessing upon blessing.

We now come to the point, and desire to know how the dear Lord is gathering, and how we may be gathering with Him, and not scattering.



We do not want our faith to rest in the wisdom of men, nor yet in our own wisdom, but only in that which God has supplied, the Holy Word, His letter of instructions unto us, which "is to be a lamp to our feet until the day dawn, and the day star arises in our hearts." Then to the Word we go. Having seen the seed sowing, the falling away, the wheat and the tares growing together until the harvest, the Lord's return from the far country again present in the earth with us and He having rejected all Sects as being unfit to be used as an instrument or channel for the harvest.

We now note the first step in the harvesting or. gathering, as recorded in Luke 12:37, `Blessed are those servants whom the Lord when he cometh shall find watching; verily I say unto you that He shall gird himself and make them to sit down (recline at table) to meat and will come forth and serve them. He here tells us that the first step in gathering would be, that He would gird himself as a servant and come forth and serve His disciples and make them to sit down to meat. This is necessary on account of the three measures of meal being rendered unfit for food, the Lord rejected it, girds himself, and causes us to recline at the table while he serves to us the pure food, the meat in due season, old things and new.

Let us get before our minds a table, and we reclining at that table, and the Lord present, girded, ready to serve us, unseen by the natural eye but seen by the eye of faith. Now how will He serve the food? There are some passages of Scripture, some people do not like to investigate closely, but we who have laid down our wills and ways, and have accepted the Father's will and way, are glad to accept any method or channel that the Lord approves.

We now note the second step in the harvest or gathering, through what channel the Lord will serve the food; as recorded, in Luke 12:42-44 as follows: "And the Lord said who then is the faithful, the wise steward whom the Lord will appoint over his domestics, to dispense the proper allowance of food in its season, happy that servant (one) whom his master at his arrival shall find thus employed, I tell you truly that he will appoint him (one) over all his property.

So we get from this passage of Scripture, that the Lord sets the table and now He appoints another to serve under him, to dispense the proper allowance of meat in its season, and appoints him over all His property old things and new.

We now note the third step in the gathering; our gathering together unto Him. "Where Lord?" was asked by His disciples, Luke 17:37 and the answer He

gave them was "For wheresoever the carcass -- the food -- is, there will the eagles -- the consecrated wheat -- be gathered together. Matt. 24:28; Luke 17:37.

Dear friends, we get from this that the food would do the attracting and that when the hour for the harvesting would come, the Lord would set the food and all the wheat class would be attracted by the food, and be gathered together unto Himself.

Let us get the picture of the table and the food be-fore our minds, with the dear Lord present at the table unseen, but serving, and the one He has appointed setting forth the meat in due season, in regular order, on the table as it is supplied by the dear Lord.

Now let us apply the illustration that has been given us, of the far-sighted eagles or vultures, seeing the carcass -- the food -- and being attracted by it, from a long distance, they hover around for a while, to see that there are no enemies present, then finally settle down on the carcass -- the food.

This is the way the Lord is doing at the present time, in the gathering. The food has been attracting the consecrated ones.

The Lord girding Himself and is serving the meat at the table, by the appointed servant and by this meat attracting and separating the wheat from among the tares, by this food; gathering His saints together unto Himself; those who have covenanted by sacrifice.

Are these to serve themselves? No, dear friends, the Lord girded Himself and said He would do the serving, and so He is.

Then what are we to do? We are to recline at the table and eat of the spiritual food that is prepared and set before us by the Lord, through our consecrated brother, the one He is using to bring forth the meat in due season, old things and new. I am sure that not one has come into present truth, without coming to the food, which the Lord has set forth through that servant whom He is using as a mouth-piece. No doubt but that it was the food that attracted us; and gathered us out from among these various Sects unto Him-self, and seeing that we were attracted and gathered by the dear Lord, unto Himself by the food, you and I may GATHER with Him and not scatter. by using the food by which we were attracted and GATHERED; by bringing it to the attention of others and if they be sons of the Kingdom they will also be attracted, and will take their places at the table which the Lord is serving, thereby aiding in gathering the Saints together, unto our dear Lord, the Head over all things to the Church, which is His body. And "without Him we can do nothing." To gather and not scatter; we will see how He is gathering, and then we will co-operate with Him, using the food and channel He is using, then we will have part in the harvest work with Him, then we will be gathering and not scattering. But if we are out of harmony with the Lord and the food that He is supplying, and the channel that He is using and desire to do some other way than the Lord's way, we will not be gathering with Him but scattering abroad.

I have great hopes, dear friends, that all here today have our wills so buried in the Lord's will, that His will is our will, and that each of us realize that He is our head because we are members of His body, and He is head over all things to the Church which is His body, and when we were consecrated and accepted as a member of His body, the yea and the nay passed from us unto Him as the head, and it now resides with Him to order all things for us. I desire to emphasize the words "all things;" nothing is left out in this expression, not one thing is happening to the church collectively or individually, without His permission. He is causing all things to work together for good. So that "in every thing we may give thanks as being God's will through Christ Jesus toward each of us." 1 Thessalonians 1:18. And this care is so close over each of us, that even the hairs of our heads are numbered; that is to say that nothing can happen to us as members of His body without His knowledge and consent.

I would like to call attention to a few pictures in the Scriptures for our edification, along the lines of Jesus the Head, and the Appointed Servant, and the Church His body. We call attention to these not to excite our curiosity, but for our edification. Not only to say we understand the picture, not only to get the teaching out of the picture to tell it to others, but that we may specifically apply it to our own selves.

So then in making use of these figures we do so for edifying. "Let all things be done unto edifying," (1 Corinthians 14:25) is the admonition.

We desire to use the figure found in Zechariah 4:2, 3, 11-14. It reads thus: "What seest thou! and I said, I have looked and behold a candle-stick all of Gold with a bowl upon the top of it, and seven lamps there-on, and seven pipes to the seven lamps, which are upon the top thereof; and two Olive trees by it, one upon the right side of the bowl, and the other upon the left side thereof. -- Then answered I, and said unto him, what are these two Olive branches, which through the two golden pipes empty the golden oil out of them-selves? and he answered me and said knowest thou not what these be? and I said, no, my Lord. Then said he, these are the two Anointed ones, (sons of oil-margin) that stand by the Lord of the whole earth."

Let us draw the picture in our minds. First, a bowl up here, then seven pipes leading down from that bowl, connecting the bowl with the seven lamp candlestick, a pipe to each lamp, all of Gold.

This, we understand, refers to the whole Church. Then we have the two Olive trees beside the golden bowl one upon the right and one upon the left. These are the Old and the New Testament, emptying them-selves into the Golden Bowl, representing Jesus, the Head over all things to the Church which is His body. The golden candlestick representing the Church. The golden pipes representing the servant over each stage of the Church.

There are seven golden pipes leading down from the one bowl to the seven lamps on the candlestick, a golden pipe for each lamp, conveying the oil from the bowl to each lamp, supplying it with oil so that it may give forth its light. These seven lamps refer to the one true church, and its seven stages of development. And the seven golden pipes, the servant the Lord has appointed over each stage of the Church to bring the proper allowance of oil to it from Himself.

Our Lord has been Head over all things to the Church which is His body and has appointed a servant over each stage of the Church. We therefore note in the figure that the Lord would select one as a servant, or pipe as the figure has it pictured, and use that one as a channel for conveying the teaching to that stage of the one true Church. When the due time came for another stage of the Church to commence, the time for appointing another servant would also come, to light up that stage of the Church, and for it to bring forth the fruit of the Spirit. So stage after stage of the one true Church was developed until finally six stages have been developed, and we are now living in the time of the seventh and last stage of the Church, the time of harvest, with the Lord present. And again He has appointed a servant, or as in the figure, a pipe, which He is using as His mouthpiece, or channel to convey the oil -- the harvest message which will produce the fruitage of the Spirit in all that are exercised by it -- from the Golden Bowl -- Himself -- to the seventh, and last Lamp, which represents us: For our enlightenment and shining forth.

If we view the Candlestick in the Tabernacle, it had a flower and an almond. To our understanding this teaches that when our Lord would bring forth the knowledge for each stage of the Church, it would also bring forth the fruitage of the Spirit, in those who received it and were conforming their lives to it.

The second figure we desire to use, teaches the same thing as the first one used. Jesus as Head, the appointed servants, and the seven stages of the Church. But in a different way.

Brother John says, "I saw seven Golden candlesticks and in the midst of the seven candlesticks one like unto the Son of Man and He had in His right hand seven stars, and out of His mouth went the sharp two-edge sword -- The mystery of the seven stars which thou sawest in my right hand and the seven golden candlesticks. The seven stars are the messengers (angels) of the seven Churches. (Rev. 1:12, 13, 16, 20.)

Let us picture in our minds the figure. The Lord stood, and about Him seven golden Candlesticks, here the Candlesticks are separate, showing that the one Church would be developed in seven stages. And the Lord standing in the midst, as Head over all things to the Church. The seven stars in His right hand, corresponds to the seven pipes in the first figure used. The stars are explained, by the Lord, to be the messengers or angels of the seven churches, and it is pointed out that they are held in His right hand, held in the Lord's power under His control, and it is here shown that it is the Lord that is doing the teaching, saying, and out of His mouth went the sharp two edge sword, the Word of God the Truth; through the Star or messenger. A star is one that shines, and that one shines "by holding forth the Word of Life," which it received from the Lord. In other words the Lord was making use of one member of the Church and controlling him, bringing forth the truth, the light for each stage of the Church, through the appointed messenger, or Star. To corroborate the thought that the Lord, as Head, would use a member of the Church, to bring the message to the Church, we read in Rev. 2:1: "Write to the Church, by the Messenger," and so it was; write to the Church by the Messenger, in each of its stages and we are now living in the last or Laodicean stage, the harvest period. And "He said write by the Messenger to the Church at Laodicea, that ye are neither cold nor hot" and in 1878 he spewed the Nominal Systems out of His mouth, rejected them, But we are in His mouth, and if we get into such an attitude of heart, that we are neither cold nor hot, we are liable to suffer the same fate and be spewed out. (Mat. 10:32, 33.)

Again we read in Rev. 1:3, "Blessed is he (the one appointed) that readeth, and they (the rest of the Church, the many) that hear the words of this prophecy, and keep these things which are written therein: for the time (kairos-set time) is at hand." When the Gathering time would come, the dear Lord would be present bringing old things and new, out of the store house: -- "Ask for the old paths." and "Behold, the former things are come to pass, and new things do I declare: before they spring forth I tell you of them" -- by the appointed servant.

The dear Lord gave us a picture in Ezekiel 12:21-28 to encourage our hearts in the gathering, and giving us the assurance of the fulfilling of all these things we see. First by pointing out the Miller movement and the failure to fulfill as they expected. Then our movement, the harvesting, with the Lord present, speaking through the Servant, and the fulfilling of the word spoken by the

Lord, with the assurance that the word spoken by the Lord, would not be prolonged any more, as it seemed to be in the Miller movement (so called.)

Verse 22 shows the failure of the Miller movement, saying, "The days are prolonged, and every vision faileth." The Miller movement set a day in 1844 for the Lord's return, and they on that day would be caught away with Him, and the earth would be destroyed, making it a vain vision. They made all the time prophecies (the days in Daniel, etc.) end on that day. And all the prophecies fulfill on that day. The day came and no fulfillment as they expected. Then went forth the saying, the days are prolonged and every vision faileth. This proverb was used till our Lord's presence in 1874 when He began to speak, to bring forth the meaning of the time prophecies and the various visions, and teachings of the Scripture on all points. When He began to speak, He said, "Tell them (that are using this proverb) therefore, thus sayeth the Lord God: I will make this proverb to cease, and they shall no more use it as a proverb in Israel: but say unto them: The days are at hand, and the effect, purpose, meaning of every vision." For there shall be no more any vain vision nor flattering divination within the house of Israel. (As they had it in the Miller movement.) and tells us the reason why, saying, "For I am the Lord: I will speak, and the word that I shall speak shall come to pass: it shall be no more prolonged:" and tells us the reason why it will not be prolonged, saying, "for in your days, O rebellious house, will I say the word, and perform it" (bring it to pass), saith the Lord God." Verse 27 shows that the Lord would use one as His mouth-piece, saying, they of the house of Israel say, "The vision that he seeth (the one appointed) is for many days to come," and that he prophesieth (teaches) of the times that are far off. Some tell me when I try to tell them that the time is at hand, "yes the Lord will come some day and He will establish the kingdom, probably in fifty thousand year from now," and no doubt this is your experience also. The next verse shows that it is the Lord speaking, through the mouth-piece, saying, "Thus sayeth the Lord God: There shall none of my words be prolonged any more, (as it was in the Miller movement) but the word that I have spoken shall be done (shall be fulfilled,) saith the Lord God." What an assurance is here given us, that what we see and know, will shortly be brought to pass. Here again we have the thought of the harvest, the Lord present using the appointed servant and the fulfilling of the Scriptures.

Now the question arises, how do we have part in the harvest work, that we may gather with Him and not scatter?

We are like the band of men who joined themselves unto Saul after his election as king by the Lord, "whose hearts God had touched." They joined him because he was the Lord's choice. And so we who are right minded, whose hearts the Lord has touched, in this harvest as soon as we see the Lord's choice, we join ourselves to him, not on account of any personal attraction, but because that one being the Lord's choice, is our choice. And our dear Pastor is also elected, you and I express our choice every year, when we send in our request for the Tower, and in this we are expressing our approval of him. We call to mind what he said about how these subscriptions were handled, and how they were now using the card system, and the question came up how large to make the case to hold the cards, and it was decided to make it large enough to hold fifty thousand. So, dear friends, if any of us have not sent in our request for the Tower, let us do so, for we need its regular visits, into our homes and into our hearts.

We see in Rev. 14:14 how the Lord sat upon the white cloud, the truth; the Lord is bringing forth the truth, and presiding over it, and we have the privilege of taking hold of this prepared cloud of truth, and drawing it over the people. We will illustrate it by this handkerchief, which I hold in my hand. By taking hold of this corner and pulling and spreading it out, and that corner pulling and spreading it out. So we may have part in this gathering with the Lord by laying hold of the Truth, the Lord has prepared and is presiding over, The Dawns, The Tracts, The Towers and by word of mouth so far as we may have attained knowledge of this message. By spreading it out over our relatives, friends, neighbors and all others, so far as we may have opportunity opened up for us by the Lord. No doubt but what we are all doing this, and every consecrated one as he takes his or her place at the table, is doing this, so by the end of the harvest this Cloud of Truth will be spread out over the people as the Lord has desired; and by co-operating with the dear Lord, making use of the food as He has prepared it, there is no doubt but that we will gather with Him, and not scatter.

Some one may say, What can I do? I do not see any use of my calling attention to the Message, nobody takes heed to what I say, and I am unable to enter other branches of the harvesting.

Dear friends, we all can have part in the tracting, and thus help in sweeping away the refuge of lies, it may not sweep away the lie but it will sweep away the refuge, so that there will be nothing left for them to dodge behind. And we can use the mails now and then in sending the message to others at a distance.

To our minds, this harvest work is a three-fold work.

First -- As this message is brought in contact with a grain of wheat, it is garnered; and they take their place at the table, and take hold of the truth, and start to harvesting, to gathering with it, according to their power.

Second -- As this message is brought in contact with tares, it drives them into their Sect bundles, preparatory for the burning; getting ready to depart. As the Revelator puts it, "The heavens departed as a scroll when it is rolled together."

Third -- When this message is brought in contact with the unheeding world of mankind, it leaves a record among them, that the Lord is now about to establish the Kingdom, in its due time, over the entire Earth. As soon as the Church is completed, then our Heavenly Father is ready to "Bless all the families of the earth, and pour out His Spirit upon all flesh." If the world of mankind would heed this proclamation of the establishing of the Kingdom, would welcome it, there would be no great day of trouble. As we see it pictured in Proverbs the first chapter: "The reverence of the Lord is the beginning of knowledge." And our Heavenly Father is by His Word, pointing out, that He is about to establish the Kingdom over the world. But the world does not reverence the Heavenly Father, nor His Word, if they did they would heed it and obey it. Verses 20-31, show the offer to establish the Kingdom, without a great day of trouble, and no heed given to it; and finally: the great day of trouble, in which they seek the Lord early, but shall not find him. If it takes the great day of trouble, to teach the world this great lesson, the reverence (or fear) of the Lord, and that it is the beginning of knowledge, the Lord will not interfere; but will permit the great day of trouble, to teach the lesson well. So that throughout all eternity, they will reverence

the Lord and His Word, which He places on a par with Himself. And this day of trouble comes upon them because they would not heed the message, as it is written. "Because I have called, and you refused: I have stretched out My hand, and no man regarded; but ye have set at naught all my counsel; and would none of my reproof." Instead of heeding these things, "They take council against the Lord and His anointed." Ps. 2:2 "When your fear cometh as a desolation, and your destruction cometh as a whirlwind: when distress and anguish cometh upon you, then shall they call upon me, but I will not answer: they shall seek me early, but they shall not find me." And gives the reason why. "For that they hated knowledge and did not choose the fear -- reverence-- of the Lord: they would none of my counsel: -- wisdom crieth without: she uttereth her voice in the streets: she crieth in the chief place of concourse, in the city she uttereth her words. --They despised all of my reproof, therefore shall they eat the fruit of their own way, and be filled with their own devices." And so we see from the Scriptures; the world of mankind will not heed. But our part is to continue to proclaim the glad tidings, "Whether they hear, or whether they forbear." Let us keep on scattering the truth, and living the life, and be as wise as serpents, and as harmless as doves. We call to mind a few Towers back, how the serpent showed his wisdom, how he ate of the forbidden fruit and acted wisely, and in this way tempted Eve. So we should eat the truth, and live in accord with the truth; so that others may see, and be tempted to eat of the truth. We know the consecrated will use every endeavor, not only to gather the wheat, hut also to carry the glad tidings to the world of mankind; so that they will have no excuse when the great day of trouble comes, to say that they have not had the opportunity to hear and obey.

But after we have done all we could, we are unprofitable servants. We have brought no profit to our Heavenly Father, He is spending time and energy to develop and fit us for a position in the Kingdom. We are to let our lights shine, and in doing so, it will bring us into trials and difficulties, and if we are exercised by them, it will form our characters like our dear Lord's. Before we can let our light shine we must be lit up. The Scriptures tell how we are lit.

"The entrance of Thy words giveth light." Ps. 119:130.

"Thou didst light up my candle, the Lord my God enlightened my darkness." Ps. 18:28.

Again -- "For ye were sometimes darkness, but now are ye light in the Lord." Eph. 5:8. And after we have become light in the Lord, we are told how we shine; how we give forth our light, -- saying -- "Ye shine as lights in the world, in the midst of a crooked and per-verse nation, holding forth the word of life." Phil. 2:14:16.

It is made plain that not all will come in contact with the Glad Tidings; only a few will receive it, and act upon it. All together a little flock, and to these watching ones it is said, "Blessed are your eyes for they see, and your ears for they hear, and it is given to you to understand the mysteries, of the Kingdom, but to them on the outside, it is said in dark sayings, that seeing they may see, and not perceive; and hearing they may hear, and not understand. The Master made it plain, what class would be able to receive the message; when he said "Thou hast hid these things from the wise and prudent, and hast revealed them unto babes."

So then, those who have the light, are privileged to shine, and have part in the Gathering.

We gather with the Lord, when we are in harmony with Him, and His arrangements, making use of the channel, and food which He provides, the Dawns, the Tracts, the Tower, etc. And "lean not to our own understanding," for His "ways are higher than ours."

We gather with Him, when we live the proper lives in our homes; in our neighborhood, and with all those with whom we come in contact, not forgetting to walk worthily with our brethren.

We scatter abroad, when we are out of harmony with the Lord, and cease to use the channel, food, and way that he is using. The Dawns, the Tracts, the Tower, etc., or when we try to mix some of our own get up with the food, thereby confusing others and scattering them, instead of gathering them to the Lord; strive to be cemented to Him ourselves, and to cement others to Him. We are to make the Truth our own, for the Lord has sent it unto us, and it is ours.

We might scatter, and also do injury to ourselves, by trying to force an interpretation, before the Lord has given the understanding, remember the time-lock will open, in due time.

We might scatter, by striving to draw away followers after ourselves, confusing them, instead of edifying them.

We might scatter, if our hearts are not right.

We might scatter, by sitting down and doing nothing, setting an example to others to bury their talent. We might scatter, by adding to the Scriptures, by adding a teaching, which the Scriptures do not teach. for example: Eternal Torment.

We might scatter, by taking from the Scriptures, by taking away a teaching, which the Scriptures do teach. For example: The times of restitution.

We might scatter, by not keeping our own standing, in the body.

We might scatter, by walking after the flesh, the world, and the Adversary instead of after the Spirit, as we should. Not living the proper life, in our home and community.

We are to gather, with our dear Lord, by striving to "lay hold on that, for which also we were laid hold on by Christ." Phil. 3:12, The character likeness of our Lord and Head.

It is not enough to merely come to the Lord, but we are to see that after we have been gathered to Him, that we go on, and in the school of Christ become copies of Him, in will and intent; that we may have "Christ in us the hope of glory" developed; so that we may have part with Him in the Chief Resurrection. We are to do as our dear Brother Paul did, "keep our bodies under," the control of the new will and bring it into subjection to it, lest by any means, that after we have carried the harvest message to others, we our-selves should be castaways from the little Flock; and another be given our place. We are to so run, that another take not our crown. And in the trials that are permitted to come to us; "work out our own salvation with fear and trembling," the predestinated character likeness, "for he has predestinated, that we should become copies of the likeness of His Son." And as we have consecrated to do the Father's will, we would like to know



what is the Father's will concerning us. We find it written in I Thee. 4:3, 4, "This is the will of God, even your Sanctification (setting apart), that every one of you, should know how to possess his vessel, in sanctification and honor, not in lust." We are to possess our vessels against the flesh, the world, the fallen angels, and the Adversary. And in all of our temptations we are to keep the body under the new will; we may possess our vessel against the flesh; and not against the world, nor against the Adversary. And again, we may possess our vessel against the flesh, and the world; and •not possess it against the Adversary. It is not enough that we possess our vessel against the flesh, and against the world, but we must also possess it against the Adversary. "This is the will of God, even your sanctification, that every one of you, should know how to possess, his vessel, in sanctification" that as we have consecrated to do the Father's will, He grants us the opportunity, in our trials, in our temptations, in our difficulties, to put our consecration (our willing to do the Father's will), into practice even doing the Father's will, not doing our own will, nor the will of the world, nor the will of the Adversary, but our Father's will, so that in these temptations and trials, we have the opportunity to practice the Father's will and way; and have His will and way formed in us, and be able to say with the dear Lord and Head, we delight to do Thy will, O God. If at the end of the race, we are able to truly say, we delight to do the Father's will, we will have kept the body under the new will, we will have possessed our vessel, against the will of the flesh, against the will of the world, and against the will of the Adversary. And our consecration will have merged into sanctification, and we will have the character likeness of Jesus in us, copies of our Lord and Head, in will and in intent, and we will have so run as to obtain the Crown of Life, The Divine Nature, and all these lessons will have been learned in the school of Christ, under our dear Lord as Teacher, who will never permit us to be tempted above our strength to endure, for without Him we could do nothing.

While we are tempted, let us not say that we are tempted of God, for the Scriptures say: "Let no man say when he is tempted. I am tempted of God, for God cannot be tempted with evil, neither tempteth He any man." And the Scriptures make it very plain here how we are tempted, and what will be the result, if we do not possess our vessel, and keep it under the new will, -- saying -- "But every man is tempted, when he is drawn away of his own lusts and enticed: Then when lust bath conceived, it bringeth forth sin: and sin, when it is finished, bringeth forth death." (James 1:13, 14, 15.)

We see here how we are tempted, by our lusts being enticed and drawing us away, from our consecration, to do the Father's will and way. And instead of doing the Father's will and way, we are tempted to fulfill these lusts of ours, the lusts of the flesh, the lusts of the eye, and the pride of life. And if we would be drawn away by these lustings of ours, if we are enticed by them, and conceive and formulate a plan, for the fulfilling of these lusts, and put them in practice, in place of our Father's will, it would bring forth sin, in the place of righteousness, and when we would become fixed in sin, it would bring forth the wages of sin, death, and to us Second Death. But when being tempted we do not fulfill these lustings of ours, but practice the Father's will and way, it will bring forth the peaceful fruits of righteousness in our lives, and when we become fixed in righteousness, it brings forth its wages, the Crown of Life, the Divine Nature, and Joint Heirship, with our dear Lord.

The flesh appeals to these lustings, the world appeals to them, and the Adversary appeals to them. But we are to possess our vessels, control them, keep them under the new will, and practice

the Father's will and way, thereby resisting the Adversary, and by so doing he will flee from us, and we will be drawing nearer the Heavenly Father, and He will draw nearer to us. We are to become like our Heavenly Father, fixed in this matter, that we will not be tempted by the evil, but have our lusts dead, neither tempt any man by drawing forth their lustings.

How are we to escape these lustings, with what force are we to meet them, and control them? We read -- To us is given "exceeding great and precious promises: that by these ye might be partakers of the Divine Nature, having escaped the corruption that is in the world through lust."

We overcome our lustings, when we are in trial, by the new will laying hold of these exceeding great and precious promises, by which our Heavenly Father is willing in us to will (desire) and to do (perform) His good pleasure. In our begetting we received the hand payment, and then we received these precious promises and in our trials we lay hold on these, they enabling us to desire and perform the Father's will, and by doing His will, we are escaping the corruption that is in the world through lust.

Let us take an example. -- We might be tempted, to strive for power and honor in this present evil world, the flesh, the world, the Adversary, all of these might be appealing to our lustings in this direction, and at this time, the Father would will in us, to will and do His good pleasure, by calling to our attention some of the exceeding great and precious promises, which are ours. "To him that overcometh will I grant to sit with me in my throne, even as I also overcame, and am set down with my Father in His throne." -- Again--"All things are yours: whether the world, or life, or death, or things present, or things to come; all are yours." And tells us the reason why, because "ye are Christ's: and Christ is God's. "Heirs of God and joint-heirs with Christ: if so be that we suffer with Him, that we may be glorified together." And "Fear not little flock it is your Father's good pleasure to give you the Kingdom." -- Again -- reasons are set forth together with the promises, why we should overcome our lustings. -- "All that is in the world the lust of the flesh, the lust of the eye, and the pride of life (ostentation of living) is not of the Father, but is of the world, and the world passeth away, and the lust thereof: but he that doeth the will of God abideth forever." "If any man love the world, the love of the Father is not in him." "Know ye not that the friendship of the world is enmity with God? Whosoever therefore will be a friend of the world is the enemy of God." -- Again -- "The flesh lusteth against the spirit, and the spirit against the flesh, and these are contrary the one to the other, that ye might not do the things that you would." -- Again: -- warnings and promises are set forth together, to aid us in overcoming our lustings. "For if ye live after the flesh ye shall die, but if ye through the Spirit do put to death the deeds of the body ye shall live, for as many as are led by the Spirit of God, they are the Sons of God, then if sons, heirs." Then, dear friends, let us strive to do the Father's will now, that we may have the promises fulfilled in us. "That after ye have done the will of God, ye might receive the Promise."

Again we may be tempted, by lusting after worldly ease, and set down and do no harvesting. -- Again we read -- "He that knoweth to do good, and doeth it not, to him it is sin," and "He that reapeth receiveth wages, and gathereth fruit unto life eternal," and "He that gathereth not with me scattereth abroad, and he that is not with me is against me."

So in all of our trials, in all of our experiences whatever they may be, after we have come to the Lord, and to His table to be fed and taught by Him, and are striving to have His character likeness formed in us, we realize nothing is happening to us by chance, but is permitted to come only by design. Therefore, "In everything give thanks, for this is God's will by Christ Jesus concerning you." 1 Thessalonians 5:18.

Dear friends, I desire to impress this one verse upon your minds, that in all your trials, in all of your difficulties, it will come to your remembrance that it may cheer your hearts, and that you may rejoice in your hour of trial with exceeding joy, and I hope you will get the blessing out of it. that I have, on more than one occasion, let me repeat it. "In every thing give thanks" (that does not leave out one thing.) "In every thing give thanks, for this is God's will by Christ Jesus concerning you." While He is forming our characters like unto His own, in the school of Christ, we may know that in every experience we have His goodness, and His mercy are following us, in forming our characters like His own, and in due time to give us a place by His side forever, then we will dwell in the House of the Lord forever. If we overcome, if we be dead with Him, we may also live and reign with Him. While we are in our trial time, we are to rejoice in tribulation, and this word came from the Latin word tribulum, and a tribulum was a heavy roller used in threshing, by being pulled around over the wheat, breaking the husk and freeing the wheat. In like manner, the Tribulum of experience is rolling over us, in our trials and difficulties, breaking down the old human nature husk, and building up the new. As we read in the Word, "We glory in tribulation, knowing that tribulation worketh patience, and patience experience, and experience hope, and hope maketh not ashamed; because the love of God is shed abroad in our hearts, through the Holy Spirit which is given unto us." Rom. 5:3, 4, 5.

Blessed is the man that bears up under temptation, because having become an approved person, he will receive the Crown of Life which the Lord promised to those who love Him." James 1:12.

And now, dear friends, we ask the Lord's blessing to abide with each of us here, and those of like precious faith everywhere, while we keep in the garnered condition ourselves and while we gather others unto Him, keeping in mind our text for edification: "He that is not with me is against me, and he that gathereth not with me scattereth abroad."

## **1:30 P. M. -- Description of Brother Williamson's Abroad.**

Upon being requested to give a short account of his experiences while abroad, Bro. Williamson very kindly gave us the following:

I would like to say in the first place in connection with my trip abroad, my association with the dear friends in Great Britain and Ireland was a source of great spiritual refreshment to my own heart. It was very encouraging to realize that in a land so far distant from us there were many who are actuated by the same hopes, refreshed by the same truths and patiently waiting for the same glorious fulfillment of the Lord's promises, as are we on this side of the Atlantic. To outsiders it might seem absurd, but to me there was a very encouraging incidental proof that we have the truth, in the fact that while those brethren and sisters are surrounded by very different temporal circumstances, in many respects, while their conditions lead them to look upon the various interests of this life from quite a different viewpoint, when they talk about the Truth they

talk the same as we do! They seem to think, and they speak and act, as persons being directed by the same holy spirit, and are therefore fulfilling the Scriptural suggestion, "Minding the same things." As new creatures in Christ they and we know not one another after the flesh, with the various interferences and hindrances occasioned by the differences of government, environments, personal interests. etc.. but look at and think of the precious things we hold in a spiritual way exactly alike. I felt that I could not ask for a better proof than this if we needed one from the outside, regarding the genuineness of our belief respecting the purposes of God revealed in His Word.

The work in Great Britain has been in progress in a systematic manner for only about seven years, and it was a special incentive to see the zeal and earnestness manifested wherever I went, and the general growth of the work in different parts of the country. It would have refreshed your hearts very much to have seen the intelligent appreciation of the various features of the good tidings we declare, and to note from the words of the mouth as well as the expressions upon the faces .how the truth has taken hold of many hearts in that deep sense which betokens the proper working of the Holy Spirit in the life.

It was a joy to be at the London Convention, as the opening experience in connection with the tour. There were gathered about eight hundred friends from various parts of the country, indicating a very encouraging amount of interest altogether, for of course this number would not represent a fourth of the total number of students of Present Truth there.

I may say that the dear ones in England are inclined to be more demonstrative than we are here, and in the meetings we heard more open expressions of praise and joy than is usual amongst us. We will not criticize ourselves unduly on this account, but I think perhaps we might encourage it to a larger degree than is manifest at present. Our Scottish friends are more like us in this respect, in that they are usually quite quiet during the meetings, although their interest is quite as deep and earnest as that of the English and the Irish.

One feature which I felt like particularly commending is the habit of taking Bibles to meetings and con-firming every statement of the speaker by reference to the "sure word of prophecy." I noticed this amongst the religious ones who came as strangers to the services. Careful following of the discourse was associated with equal care in noting Scripture references, which not only increased the impression respecting the truths uttered, as being surely based upon the Word, but also insured the carefulness of the speaker in referring to the Word, so that his positions would be properly buttressed. I was much impressed by this point, and have been particularly helped by it in endeavoring to make as clear as possible, in public presentation, how emphatically the Bible presents the plan we delight to proclaim. It was interesting to see how the countenances of persons in an audience expressed astonishment as each assertion was shown to have the full endorsement of the Scriptures, reference to each of which was given, and the exact words read before all. People in this country seem to have something of a shame-faced feeling in taking a Bible to a meeting, which prevents their receiving the same amount of benefit otherwise obtainable. (This, of course, does not apply to the friends of the Truth, who recognize the Scriptures as their only authority in every presentation of truth.)

One of the interesting incidents of the London Convention was the testimony of a man who heard the truth expressed for the first time at the first evening meeting. Interested by the presentation, he took home some tracts, and came the next morning, and when the opportunity for testimony was given he promptly took advantage of it, and announced, to the amusement and joy, as well, of all the friends, "I've been in the truth just twelve hours!" He came to every service there-after, and as he was employed at night he had to choose between the meetings and sleep in the day time, and preferred the meetings, that he might get all the spiritual blessing possible -- getting no physical refreshment until after the Convention was concluded. At each testimony he reported the number of hours he had advanced in the truth, and I was glad to find, on my re-turn to London at the close of the tour that he was still rejoicing and progressing in the Lord's way,

Another incident illustrated the Lord's overruling providence in bringing a lady to the convention through the invitation of my aunt (not herself specially interested with us, but desirous that the lady should become acquainted with me for family reasons). She came to the concluding service, introduced herself as a member of the Church of England (not usually demonstrative people as regards spiritual matters), and was so much interested by what she heard, following closely Bro. Hemery's discourse of the evening, and the Scriptures cited, that she participated in the love feast at the end, coming forward with the others of the audience, and shaking hands with all the elders gathered at the plat-form, and subsequently exclaimed to me, "You are the most wonderful people in the world; I never saw any like you! I think the Millennium must have begun in you already!" Her eyes meanwhile shining with enthusiasm and earnestness. She went away with a large supply of literature and a determination to study matters for herself. The Lord bless her with the truth!

Another interesting incident was the development of deep interest in a whole family, the children in which had been attending a Roman Catholic educational institution, and were seriously contemplating entrance into that anti-Christ system when in the Lord's providence they were brought in contact with the Harvest message. They evinced much intelligent appreciation of the various features, notwithstanding the children were still in their teens.

It may seem quite an opposite extreme from Catholicism and Episcopalianism to speak of the Salvation Army, but here the Lord has been finding some precious grains of wheat also, and some very prominent workers have been harvested from that organization, their spiritual senses being turned to something more satisfying since worldly prominence given to General Booth and his humanitarian projects, through the Army's agency, have apparently squeezed out much of such spiritual thought as may have been existing amongst them previously. So the Lord is gathering from opposite ends of the harvest field, and so we are being encouraged and refreshed as we consider His gracious providences and our own permission to participate, even in very humble cooperation.

It was a source of much encouragement to my heart to note the deep love for our dear Brother Russell manifest amongst the British friends. While we all realize that our dear brother seeks nothing of us in adulation, and while none of us would consider it appropriate to indulge in man-worship; we do recognize that the Lord has brought us great blessing through a servant who has been humble enough to be made use of, and it refreshes us on this side the ocean to see the recognition of the situation by the dear ones on the other side. Wherever I went I was blessed in

noting the affection the friends have for the Lord's servant, and their earnestness in giving expression to it. It was not infrequently the case that when, as a Church, it was desired to send a message, through me, to Bro. Russell, the dear brother expressing the congregation's sentiments was obliged to stop in the middle of his remarks, with tears coursing down his cheeks as he reflected upon the Lord's leading and the escape from spiritual darkness into precious heavenly light experienced through Millennial Dawn, and in a choked voice to say, "I -- I -- can't say any more, Bro. Williamson -- you see -- tell Bro. Russell how we feel." And I did see, and felt that the message was the more emphatic because of inability to put it into words.

The friends are very studious, too. They are not inclined to take matters for granted, and I felt this in many instances in the questions propounded in private conversation. They manifested a determination to "Prove all things," to "Study to show themselves approved unto God," and as a result the Lord is blessing them. If a word might be said on the other side a word we ourselves need, as well as they) it would be that not only is the intellect to be trained to study the doctrines of the Word, but the heart is to be trained in the development of the character which shall make us ready for the Kingdom, and I know of nothing better to aid in that direction than the prayer, praise and testimony meetings, which give special attention to encouragement of thought along the essentially spiritual lines. leaving the "Dawn Circles" for the discussion of doctrines.

I found that the Lord had been blessing some of the incidental helps provided for our refreshment in these closing hours of the harvest-day. For instance, the "Heavenly Manna," with a text for each day in the year, was specially blessed to a dear brother who was hesitating about whether or not he should be baptized. Looking up the "Manna" text for his birthday, on the morning of the day the baptism was to be held, -- as he opened at the date and read the text, he dropped the volume in amazement. The text read, "Why tarriest thou? Arise and be baptized!" The dear brother realized that God had sent him a message, and he promptly fulfilled the injunction. I learned of a number of other almost as striking applications of birth-day texts to the personal experience of the individuals whose births related to those dates, which seemed quite remarkable.

I found amongst the people a marked decadence in the religious spirit, which surprised me greatly, for I had always idealized Britain's element of religion, remembering its faithfulness in many respects to light in Reformation times and since, but it emphasized the fact that we are reaching a climax in the world's history. On the one hand I realized that many are being indoctrinated with the "New Theology" the chief exponent of which just now is the pastor of London's famous City Temple. One of his many remarkable propositions, which seem to make it the more strange that supposed Christians are deluded by his views, is -- "Sin is a seeking after God!" And yet one sister told me that after her daughter, intellectual and clear-headed, had heard a minister expound these views, so fascinating was the presentation, and so plausible were the arguments, that had she not heard her mother explain the plan of the ages, and thus had the true response to give in her own mind to the sophistries, she would have espoused the error at once! On the other hand, I found many independent Christians, driven from denominational association by lack of spiritual provision for their hunger, anxious to increase in knowledge of the Lord's way, and grasping at the truth as it was presented to them. In a number of communities these little groups have come into the present light almost in a body, and have given great joy to those showing forth the enlightening message. This was the case in Leicester, where twelve embraced

the clearer Gospel after having been associated with a modified form of Christadelphianism for several years -- the modifications representing the independent spirit which de-barred them from acknowledgment by regular Christadelphian circles.

I likewise found a readiness to frankly assert antagonism in the public meetings when individuals felt opposed to the message presented; and on the other hand an equal readiness to express approval when the latter sentiment prevailed -- both attitudes being unusual to one accustomed to audiences in this country, where either sentiment is only expressed after the meeting is closed. At Luton we had to contend with a New Theology exponent; at Leeds, with a Christadelphian, who seemed much incensed because the discourse was so lengthy that he could not have a good opportunity to express himself, in Scotland with some old-fashioned Covenanters, and others; and in Devon-shire with some city missionaries. The interest, however, preponderated on the side of hearing the truth, and the Lord seemed to bless the experience of interruption so that more close attention was given by the others, and we trust the truth was still more thoroughly impressed by the Lord's Spirit.

In one of the Scottish towns we endeavored to present the subject of "Hell," and to show the Scripture testimony of a hope of return therefrom. After explaining the real significance of the original words as "sheol" in Hebrew and "hades" in Greek, and that "Hell" meant the death-state, we quoted Rom. 5:18, "As by the offence of one judgment came upon all men to condemnation," and suggested that this signified that one man, Adam, sent the whole world to hell, the tomb; then continued, "even so, by the righteousness of one, the free gift came upon all men unto justification of life," which meant a coining back from hell for everyone whom Adam had been the means of sending there. At that declaration a man jumped up from the middle of the audience and shouted, "Blasphemy! Blasphemy! I am surprised that any Scotchman would listen to such stuff!" Immediately another man arose in another part, and shouted, "Sit down, sit down: This man hasn't said anything yet except what he has proved from the Scriptures!" Of course confusion reigned, and the meeting might have broken up, but I suggested that there was still much to say, that we were only appealing to the Bible, and that we wished all who were interested in that book to hear us to the end; but that those not interested in the Bible we would be glad to see go out. Thereupon two men left the room, and the remainder, after considerable applause, listened patiently to the end. I learned subsequently that the defender in the interruption had first read volume one of Dawn in India, and had evidently gotten some blessing from its perusal.

The Devonshire experience was still more stirring. It was the first meeting held in public in the city of Plymouth, where a dear sister had been serving and studying the truth practically alone for several years. with a certain amount of sympathy from another lady, who refused to be called a "sister," but who, I found, was as enthusiastic a sister-in-law as I should want to see, so far as our meeting was concerned. She co-operated enthusiastically in the circulation of the announcements, sending them to every minister in the city with the request that they be read at the Sunday services, and to ten or twelve of the suburban towns, as well as sending out her maid to distribute them to people in the city. The latter got considerable of the enthusiasm also, for she voluntarily distributed the circulars to a congregation as it was leaving its place of meeting while she was passing by. The ladies secured a prominent gentleman of the city to act as chairman; the mention of whose name on the program induced a good attendance of persons not likely to have

been attracted otherwise -- all in the Lord's providence, I feel sure. The chairman had accepted the invitation with considerable doubt, and showed it in his method of introducing me, which was to read what he had to say from a paper he produced from his pocket. He re-marked that he had at first supposed the occasion was to be a Bible study, and remembering much profit he had derived from such a meeting conducted by an American lecturer ten years before, he hoped this also would be profitable; but later he learned that there was to be an address, upon a very peculiar subject---"Is there Hope Beyond the Grave?" He had no idea what was going to be said, but had been assured that it would be in harmony with the Bible, but he did not wish to be understood as endorsing the matter before-hand; all he asked was that the audience would pay careful attention and seek to get as much profit from the address as possible -- which was a very fair way of stating the matter, and we could not have asked for anything more.

In endeavoring to emphasize the Bible hope beyond the grave we used that eloquent text, John 3:16, which emphasizes the love of God for the world, so that whosoever believes upon Jesus Christ might have eternal life, and then sought to show that there were several periods in the history of the race in which God had shown special favor to a few, to the apparent exclusion of the rest, as for instance, in the world before the flood, when Abel, Enoch and Noah were specially blessed. Then it was suggested, "If God blessed these, and no others, and has made no provision of a hope beyond the grave, so that the majority died in eternal despair -- then John 3:16 is not true!" At this a burly, red-faced man in the audience shouted out, "It is true!" Of course I was ready to admit that but knowing that a direct answer was likely to precipitate argument and diversion from the real subject, I simply reiterated the point, ignoring the interruption, whereupon the remainder of the audience manifested approval by vigorous applauding and quite angry looks at the interrupter. Proceeding, we endeavored to show the method of selection of Abraham, Isaac and Jacob, to the apparent exclusion of all others, and repeated the assertion that if all but these elected ones died without any hope of a future blessing -- died in everlasting despair -- John 3:16 could not be true, since in such an event God would not be properly said to have loved the whole world. The interrupter broke out again with, "Let every man be a liar!" and another added, "Is this an American invasion?" The Lord gave grace to answer these at-tacks with quietness, pointing out the orderly arrangement of the meeting and the desire to pursue the subject without interference, requesting those not interested in the Word of God to leave, which evoked an-other manifestation of approval from the audience, and further indications of strong feeling against the ones who were interfering. Quiet prevailed for fifteen minutes, while we emphasized some texts referring to God's comprehensive love for the world, as in 1 John 2:2, "He is the propitiation for our sins. and not for ours only, but also for the sins of the whole world." At this another man arose to assert, "This man is not quoting the Scripture right -- it doesn't say 'sins,' it says 'sin' " -- which was not only untrue, but quite pointless, so far as I could perceive. Having made a brief response to this, also received with applause, the discourse continued, the antagonism having the providential effect of stimulating the strongest effort to make the truth clear and convincing to those who might have the "ears to hear." As a result deep interest was manifested, and all took tracts as they left the meeting, and several purchased The Divine Plan of the Ages. to which attention was called at the close. The chairman himself re-marked, "Well, I must admit that I came to this meeting in a very dubious frame of mind. My friends said they did not know why I allowed my name to be attached to that circular, and I didn't know either, but I am glad to say that I look at matters differently now that I have heard this discussion. I see your view more clearly, and I am much interested. I have that book at



home, and I am going to read it thoroughly." We praised the Lord that He had graciously overruled and given a blessing in the midst of disturbance.

In Leicester two Sunday School teachers came to the public meeting Saturday evening, and each purchased The Divine Plan and took a large quantity of tracts. Next evening they came again, their interest still at its height, and said they had given all the tracts away to the Sunday School scholars and wanted more! They stated that they had been hungering for more information respecting the Lord's plan for some time, and felt sure they were in the way of getting it through the present message. At the same meeting an infidel was present, who wanted to know what proof we had that the Bible was the Word of God, and when he was recommended to read the Divine Plan asked us what relationship we stood in toward the denominations in general. Fearing to stumble the first beginning of interest by a reply suggesting condemnation, I thought best to have him answer his own question, and so asked him what he thought of the topic discussed that evening. He replied that he considered it the most reasonable explanation of the matter he had heard. "And what do you think of the denominational teaching?" "I haven't heard any that I thought was satisfactory at all." "Then doesn't that answer your question -- what our relationship is to the teaching of the denominations?" He saw the point, and said, "Yes -- that's so! I'm going to take this book home and read it carefully, and when I've done I'm going to come back and tell you what I think. If I like it you will know, and if I don't I will tell you where it is wrong!" Which was exactly what we would like everyone to do.

I met three other infidels on the tour -- one in Bradford, another in Belfast, and another on the boat returning to New York. The Lord graciously blessed the precious message to each of them in some degree at least, stimulating them to a further study of the Word which has been so maligned by false friends, who preach "another gospel, which is not a gospel."

By the way, the last-mentioned infidel was so much interested in what he heard that in private he requested prayer, and, together with a Christian cabin-companion, we prayed, and had the joy of hearing the erstwhile infidel make confession of sin, and accept the blessing of justification by faith, following which he took up from his berth a copy of Tom Paine's "Age of Reason," which he acknowledged as having been his guide for the previous three years, and flung it with all his might through the porthole into the ocean, saying, as he did so, "There, Tom Paine! I've followed you long enough; now I'm going to follow the Lord Jesus Christ." He promised to read the first volume of DAWN, which we assured him would lead him into still more blessed experiences as a child of 'the Lord.

In the city of Manchester an old white-haired man pushed himself forward at the close of the meeting, to introduce himself because he possessed the same name as the speaker. He made no mention of having been interested by the discourse, having apparently only come because of the coincidence in names, but took some of the tracts home with him. He was back the next evening, and at the close of it stated that he had been so much interested in reading one of the tracts that he remained out of bed until four o'clock in the morning to finish it!

In Glasgow we had many refreshing experiences. The Church there is a very flourishing one, built up by the earnest zeal of dear ones who have become interested within the past ten years. At that time the interested ones who gathered in the first meeting held numbered seven, in a "little

back shop" whose proprietor was a dear old sister now familiarly known to many of the friends throughout Britain as "Aunt Sarah." It was she whose energy began some of the work which has attained large proportions today. "Aunt Sarah" had for a long time been deeply interested in the second coming of Christ, expecting Him to come at any moment, and earnestly desiring to be ready when He came. Providentially meeting our dear Bro. Hemery, then of Manchester, who "showed her the way of the Lord more perfectly," she readily grasped the truth respecting the "parousia" of the Lord, and the Scripture teaching regarding His coming as a glorious spirit being instead of in His Body of humiliation. In her zeal to proclaim the truths she had begun to learn she aroused the anxiety of her relatives to an alarming degree, they finally determining she must be mentally unbalanced, and at length calling in a celebrated physician to examine her mind. It is a rather remarkable coincidence that the physician called was Dr. John Edgar, whom we all today very dearly love as a brother in the Lord, although I am not able to climax the incident by stating that it was through this professional visit that the doctor became interested in the truth. That came later, after the work had made some progress in Glasgow', through the entreaty of his sister, now Sister Minna Edgar, that he read the DAWNS, she having become meantime deeply interested through meeting our dear Bro. Hemery, and learning from him the blessing of the truth now due to be understood.

"Aunt Sarah" had circulated many tracts setting forth her former views on the Lord's coming, although, being obliged to pay for every tract she needed, the circulation was naturally limited. She told me she used to say to herself sometimes, "I wish some old lady would die, and leave me a lot of money to purchase tracts!" And when she found Present Truth, and realized that she could procure all the tracts she wanted without having to pay anything, her joy was unbounded. She immediately wrote to the British Branch in London and gave an order for thirty thousand tracts! You can appreciate the faith which inspired our dear sister, and the zeal she desired to manifest. And God richly blessed her efforts, for I found that many persons had had their start in studying the truth through receiving a little "Evolution" booklet which was the particular one our sister ordered when she started to circulate "free tracts."

In the early, discouraging days she was sometimes asked the question, in a bantering way, "Well, how many converts have you gotten to your new religion?" and her reply always manifested her faith. She said once, "No one yet; but never mind; some day we will have St. Andrew's Hall for our meeting!" -- referring to the largest public hall in Glasgow. And sure enough! when Bro. Russell again visits Great Britain the Glasgow Church purposes engaging that same St. Andrew's Hall for his public address, and dear "Aunt Sarah's" cup of blessing will be full! So different are the conditions there today as compared with ten years ago, that the Church was able, under the efficient direction of another devoted brother there, also a doctor, Bro. McMillan, to circulate in one week announcements of a public service in the second largest hall in the city, to the number of 52,000, bringing out an attendance of over three thousand persons, who listened very attentively to the message we had to bring them. You may judge the feeling of weakness of the poor speaker in being called upon to face such an audience as that! Only the grace of the Lord permitted the carrying out of such a task, and whatever blessing may have resulted is attributable only to His loving kindness in overruling the imperfections and deficiencies manifest. Prior to facing the great gathering the elders and the speaker gathered in a little ante-room for prayer, that the Lord might guide and overrule, and just before stepping upon the platform I received a telegram which brought much comfort and encouragement. It was sent by dear friends in

Manchester, with but three words in the message: "Joshua one nine," being a reference to the book of Joshua, chapter one, verse nine, which reads thus: "Have not I commanded thee? Be strong and of good courage; be not afraid, neither be thou dismayed; for the Lord thy God is with thee, whithersoever thou goest." It was certainly a very special help in time of particular need.

Doctor McMillan, to whom I have just referred, holds the highest position in dentistry in Glasgow, as Doctor Edgar does in his special branch of medical practice, and the zeal of these two men, so prominent from the worldly standpoint, is very striking. Dr. McMillan's interest was first excited by Bro. Edgar, but there was a good deal of hesitancy about taking hold of matters earnestly for some time, our brother taking the view urged frequently by those we seek to interest, "If these things are true why do not some prominent ministers put them forward? Since none such do endorse them surely they are erroneous." The brother had specially in mind the doctrine of the immortality of the soul, and when, to his astonishment, the denial of that doctrine was emphatically advocated by one of the prominent Methodist college professors of England, Dr. Joseph Agar Beet, Dr. McMillan concluded that he had his answer, and proceeded to study so thoroughly that he is now heart and soul in Present Truth -- helped thereto, quite unwittingly of course, by the Methodist professor.

Edinburgh, the home of Scottish history in many respects, gave an audience of seven hundred to hear the truth publicly proclaimed, whereas the interest was so small when Bro. Russell was last there that but fifty heard him in a small room in the same building in which the large hall used on this occasion was located. Here a young Armenian showed much interest, and after attending several of the meetings introduced him-self as a college student, very anxious to know more of these precious things, and stating that he was deter-mined to make a study of them for himself. This re-minds me that there are two Armenians fully consecrated to the Lord in England, anxious to return to their own country to spread the glad tidings there. So that, with a whole family of that nationality living in this country the representation in Present Truth from that people is quite good, and reminds us of Rev. 5:9, 10.

I found deep interest in Ireland also, although the number of churches as yet is but two. Conditions are very different there from either England or Scotland, on account of the still prevalent bitter feeling between Catholics and Protestants. Good hearings were accorded, however, in both Belfast and Dublin, and the brethren are very zealous in both cities, being very anxious to make known the glad tidings to all who have an ear to hear.

Coming back from Dublin to Liverpool, the singing of a farewell hymn by the Dublin friends on the landing stage as the boat moved out attracted the attention of the passengers and led to conversation with a gentle-man who showed that his mind was meditating upon the unsatisfactory conditions in Christendom, and the need for some greater power than the Church has been able to exercise during its humiliation to bring in better arrangements. This led to arrangements to meet again in England, which were subsequently fulfilled, and' the gentleman now has DAWN Vol. I and states that he will read it carefully.

The same readiness to attack the truth on the part of "hireling shepherds" is shown amongst the experiences of our British friends as we are able to show in this country. In one case a young sister sought her pastor's advice regarding her study of DAWN teaching, hoping that if she were

in error he could make the matter so clear that she would have no doubt as to her future course. Instead of performing a proper shepherd's duty, if his sheep were going astray, however, he launched out into invective, and said harshly, "If I had my way with those people I would put everyone of them into prison for interfering with my congregation!" The un-Christian remark decided the enquirer, and she at once withdrew from the congregation.

In another case, quite the reverse of this, a number of the members of a congregation arranged a prayer-service on behalf of a brother who was beginning the study of the truth and was presenting it so clearly to the pastor, through the newspapers, that the latter was kept in a good deal of hot water. The intent of the prayer-service was to ask the Lord to keep the dear brother from error! The brother today rejoices in the prayers having been answered, and that he is standing fast in the truth, by the Lord's grace.

I found very few "clergymen" taking any interest in the precious message we proclaim, but was glad to learn of, although I did not meet, two who endorsed the message and gave it earnest commendation. One of these preaches the truth every opportunity he secures, including his regular ministrations to his congregation, and we are sure this faithfulness will bring him blessing, even though it may bring him much persecution before long. Since my return I learn from a newspaper item that he gave an excellent discourse on the times of restitution and the world's great need in this respect to an attentive congregation in a city where I had been and where, so far as I know, but two strangers were present to hear our presentation. Evidently the Lord can and will use our brother in ways that are not open to others of us, in which we greatly rejoice.

If, however, ministers in general are not so appreciative, there is a class of religious teachers who are being helped to a considerable extent -- and that is, local preachers. In one community in the southeast of England four of these brethren came to a realization of the harvest message, and three of them appreciated it fully and are declaring it actively -- one of them now beyond the veil, and the other two still on this side.

In Yorkshire a still more remarkable manifestation along this line is given. A local preacher saw a copy of "The Time is at Hand" in a book-shop (as they call it) and being attracted he bought and read it. Deeply impressed, he lent it to a brother worker, who was greatly stirred, and in consequence they began to study together systematically. As a result, six local preachers came into Present Truth in the one community, and so aroused discussion and commotion amongst the church people, as well as the public, that the news-papers far and wide published long articles on the subject. These articles were woefully distorted statements of the facts, and I am sorry indeed to say that the members of the congregation to which the brethren had belonged were evidently responsible for some of these misrepresentations, especially in giving a perverted statement of the contents of the resignation the brethren submitted to them. Nevertheless, the way was opened for them for spreading the truth, for the whole country became to a considerable degree excited about the news-paper reports (which spread even so far as Africa and this country eventually) and the brethren in different parts effectively advertised public meetings to explain what our views really were. The public references to the brethren mentioned them as "Millennial Dawnists," and this phrase gave rise to an amusing incident which I think I must mention, remarking in explanation that the British people pronounce the word applied to the white, light

metal now in general use, which we call "Al-u-min-um" somewhat differently; they say, "Al-umin-i-um" -- giving an extra syllable. A countryman was in the little town these brethren resided in, while the excitement was at its height, and conversing with a merchant, he remarked, "Say, this is the place where those al-u-min-i-um Dawnists live, isn't it?" The merchant was highly amused, and thinking it a good nick-name, perhaps, sent it along, so that soon it was over the entire community, and many persons today refer to our friends in that vicinity as "Aluminium Dawnists."

I have already said too much, but I should like to add a few words respecting some of the means the Lord has used to bring individuals into the truth. For instance, one dear sister was greatly perplexed because her two sons were going so far away from what was right, as she thought, through reading "these terrible books," so she resolved to help them into light again by studying the books to show them their errors. The Lord blessed her earnest heart, and brought her into the truth also!

In another community a dear brother adopted the method of sending literature to establishments where there were a good many employees, and addressing the package to "Mr. Smith," hoping the matter would reach some hungry one. The Lord directed the truth thus to a man whose name was not Smith, but who suspected that the address was fictitious, and appropriated the literature to himself, after waiting a time for a probable owner. The result was a great blessing to the man, and eventually the interesting of quite a little company in that vicinity. I have notes of a number of other interesting incidents where literature was sent to addresses which could not be located, and which eventually reached the hands and hearts of those who were earnestly desiring greater light. One dear brother so reached, after he had been himself refreshed, was so anxious to refresh others that when he heard the milk-man leaving the milk at the front door one morning he determined to get into communication with him. When he got to the door, however, the man was already in his wagon, and the brother followed him for a mile up the street to tell him some of the good tidings of great joy which had come to his own heart.

Another, a sister, greatly distressed at the sight of sin, suffering and misery revealed to her as she walked down the street on a Saturday night, in company with her husband, and feeling greatly, weighed down by the apparent inefficiency of any methods in operation for helping the situation, went to the Lord in agonizing prayer, uttering a sentiment she supposed the next moment to be a terrible blasphemy, but expressed out of an overburdened heart. This is what she said: "O God, if I only had your power for two hours, I would make conditions very different!" God saw her heart, and the next day He gave her the answer -- The Divine Plan of the Ages, which has settled the question, and has brought to her heart the comforting realization that God's care will soon be gloriously manifest to all.

In another instance a sister received the message in moving into a vacant house, where she found Vol. I of Millennial Dawn lying on a table -- the only article in the house when she arrived with her goods. And in another, a husband and wife experienced the blessing the Lord had for them through a magazine copy of Vol. I which had been sent from Allegheny to the clergyman for whom they were working, and who contemptuously threw it into the waste basket, with the remark that it was only "another freak religion from America!"

A colporteur had a curious experience which the Lord overruled. A lady whom she canvassed asserted that she wouldn't read that kind of literature under any consideration, but that she would buy the book, for there was another lady against whom she had a grudge, and to whom she would send it! This she did. The second lady likewise had no use for the book, and laid it aside. When, however, some one called to ask for a donation for a church bazaar she bethought herself of the book, and thinking thus to rid herself of it gave it to the caller, who made it up for the bazaar, where it was duly displayed for sale. The minister of the congregation soon noticed it, but strangely enough, had never heard of it before, and being somewhat struck with some phrases purchased the book and took it home. His further reading developed a strong antipathy, which he displayed in a series of sermons against the views expressed. Remarkable to relate, perhaps the congregation did not wholly endorse the minister, but took different sides, some with the book and some with the preacher, as a result of which a number began to read the literature, and the Men's Club put a set of DAWN into their library for convenient reference of all the members! Whether anyone became deeply interested does not yet appear, but it indicates how the Lord makes use of some people's spite to make known his truth.

I must close this subject. Hundreds of other interesting details of my tour, and of the deep interest and growth of the British work might be related, but time forbids. But one thing more I may say, and that is that in whatever proportion the dear friends may have, through the Lord's overruling, received any assistance through the visit made to them, I have derived a hundred times more than could have been imparted to them, -- blessings which I trust by the Lord's grace shall continue to inspire me as they do now until the end of the pilgrimage, and thus enable me to run with patience the race, and to make my calling and election sure to the Kingdom.

### **3 P.M. - Discourse**

*by Brother E. H. Thomson, of Washington, D.C.*

#### **Topic: "The Three Fires of the Atonement Day."**

OUR LORD told his disciples, "If any man will come after Me, let him deny himself, take up his cross daily and follow Me" (Matt. 16:24)." I am glad to believe that practically all present are His disciples, students in the great school of Christ, and that all use that most wonderful text-book, the Bible. In it are found not only the rules and instructions, but also examples, illustrations and types, and these, we are told by Brother Paul, "were written for our admonition upon whom the ends of the ages are come." (1 Cor. 10:11). Prominent among the types is the Atonement Day with its sacrifices, typical of the great antitypical Day of Atonement, the Gospel Age (Lev. 16:29-30; 2 Cor. 6:2).



**Brother E. H. Thomson.**

Your attention is invited this afternoon, however, to only a part of the ceremonies of that typical Day, the sacrifice of the bullock of the sin offering and the Lord's goat, and in order to properly apprehend their significance we need at least briefly to survey their surroundings. We have already, through the apostle, identified the Gospel Age as the antitypical atonement day and by the same authority may recognize in the court of the tabernacle the condition of justification reached by faith in Christ (Rom. 5:1); in the bullock the man Christ Jesus (Heb. 10:5, last clause); and in the Lord's goat the Church who participate with their Head

in His sufferings, reproach and finally his exaltation (2 Tim. 2:11-12). By the altar we see represented faith in the ransom sacrifice, upon which basis all these sacrifices are offered, the fire in every case representing the same thing, the sufferings and trials which the course of faithfulness and obedience entail upon the sacrificer. The sacrifice of the bullock alone represented the death of the perfect man, Jesus, the satisfaction of justice, the payment of the ransom; while taken in connection with the sacrifice of the Lord's goat the two constitute a type of the great sin offering for the world, the death by sacrifice of Jesus, the Head and the Church, His Body.

It is this latter point of view we wish especially to consider now. In the account given in the 16th chapter of Leviticus, verses 11 to 15, 25, 27, 28, we find the same course followed with the goat as with the bullock, and we find three fires upon which the sacrifices are consumed, the first mentioned being the fire upon the golden altar in the holy, then the fire upon the brazen altar in the court, and finally a fire outside the camp upon which the carcasses were completely burned.

### **Types Only for Illustration.**

At this point permit me to call attention to a wise warning in our Berean Topical Index under the heading of Types and Figures. "A type must not be used to teach a doctrine, but merely to illustrate one that is elsewhere taught in plain terms." I want to heed this warning and apply it this afternoon by using our Lord's words first quoted as my text and these types as their illustration. He told His disciples of three steps necessary for all who would come after Him, namely, self-denial, cross-bearing and following Him, and those three steps are portrayed in the three fires we are considering. Let us take them in the order he suggests.

### **The Fire in the Court.**

fitly represents the trials and sufferings entailed by an acceptance in this age of God's will instead of our own. The presentation at the door of the tabernacle of the bullock and the goat typified that which Paul quotes in Heb. 10:7: "Lo I come to do Thy will, O my God." Since God's will is our consecration unto death, the bullock and the goat are both slain and their fat, much in the case of the bullock and very little in the case of the goat, is burned upon the altar, causing much smoke to ascend toward heaven.

Herein we see an illustration of the loving zeal which the fire of trials and suffering only causes to send forth more visible evidence of our devotion to our Heavenly Father's will, and by which our Lord proved and we may prove that "I come \* \* \* not to do mine own will but the will of Him Who sent me." "Not my will but thine be done." For, as Paul says, "Even Christ pleased not Himself."

The smoke of the burning fat, the evidence of our loving zeal, ascends as a "sweet savor unto God" and is visible also to all who are in the court, the justified condition, and is understood and appreciated by them, even if all are not themselves sacrificing priests. Indeed to those who have not made a similar consecration it is an incitement unto love (toward God) and good works (towards men).

But one asks why should there be suffering and trials typified as being received in the court. I believe, dear friends, we may find here a pointed lesson that our self-denials and our zeal are bringing upon us many pains and sorrows from the very ones whom we especially seek to serve, namely, the household of faith. From the head of the body down to the feet -- members yet upon earth, who has not suffered from the other members. In many cases it is through ignorance. Weaknesses also are our constant occasions of causing and receiving suffering from one another. Again, what pain and mental anguish have been the result of misunderstanding the motive or the act itself. Finally can we not all testify to our trials through the lack of harmony, even at the very times when we are endeavoring to preserve the unity of the spirit? Nevertheless we have "bound the sacrifice with cords even unto the horns of the altar," and are "filling up that which is behind of the afflictions of Christ for His Body's sake," and in the words of David, written prophetically of the Christ, we cry "the zeal of thine house hath eaten me up" (consumed me) (Psalm 69:9).

Yet, my brethren, though we take the cup of salvation and call upon the name of the Lord and pay our vows now in the presence of all His people (in the court) zeal alone is not sufficient. Paul wrote of the Jews that they had a zeal toward God but not according to knowledge (Rom. 10:2). Let us go on then and study the lesson of

### **The Fire Outside the Camp.**

and see in what way it illustrates the second condition laid down by the Lord for those who would be followers of His Son. Jesus said, a taking up of our cross daily -- which has been defined as doing the will of God under unfavorable circumstances. So in the burning of the carcass we have the death of the body and in the fire the fiery ordeal of sufferings which our continuous submission to the will of God brings upon us. Our consecration is "unto death" not only of the human will but of the body. As the Lord through the prophets declares, "I said, ye are gods, all of you sons of the Highest, yet shall ye all die like men." So we are exhorted by the apostle as "Jesus also, that He might sanctify the people with His own blood suffered outside the gate" so "let us go forth unto Him outside the camp, bearing His reproach" (Heb. 13:13). Leaving our father Adam's house, leaving the world and its ambitions and conventionalities we too become by faithful obedience to our covenant of sacrifice crucified to the world, and are reckoned by it as the "filth and offscourings," and become a stench in the nostrils of our former friends and acquaintances. To the worldly wise our course is looked upon as foolish, for the cross has always been to the Greek -- the educated and refined -- "foolishness," and to the Jew -those who are nominally God's people -- a stumbling block. Our sacrifices, by God's grace, a part of the sin offering for the world, are esteemed as unnecessary and are therefore unappreciated as was our Lord's. "He was despised and rejected of men; a man of sorrows (miserable man) and acquainted with grief, and we (the world) hid as it were our faces from Him; he was despised and we esteemed Him not" (Is. 53:3). As our beloved Head has said, "it is enough that a servant be as his Lord." It is our privilege then to be "always bearing about in our body the dying of the Lord Jesus, that the life also of Jesus (the operations of the new mind) might be made manifest in our body" (2 Cor. 4:10). It was during the dying years of our dear Lord's life, during His doing of the Father's will under the unfavorable circumstances, during His cross-bearing that He told Philip "he that hath seen Me hath seen the Father." It was the Father's love which He manifested in the great sacrifice of Himself and it is the same love which we may manifest in our life of sacrifice. Indeed the type wonderfully portrays the love of God in the provision made (Lev. 16:28) for the



return into the camp, after the burning of the carcasses, of the man who carried them forth. In the man we see a type of the class who "have condemned and killed the just" and we find that they may wash their clothes in an experience in trouble -- and bathe their flesh in water -- in the truth during the day of their visitation, the millennial age. As Peter says, they did it in ignorance and Paul says none of them knew. So we can be filled with pity for those who persecute us and can pray for them as did our dear Lord, and like Him we can even die for them, for hereunto are we called.

But as our burning zeal, the smoke from the brazen altar ascends as a sweet savor unto God, so we are told that "precious in the sight of the Lord is the death of His saints" (Psalm 116:15).

Yet, my brethren, though we have sacrificed our own wills, yea, if we give our bodies to be burned, it profited nothing unless we fully carry out the type and learn the lesson of

### **The Fire In the Holy.**

Let us remember that the priest immediately entered the Holy with the blood fire from the brazen altar and both hands full of incense. As soon as full consecration has been made and we have been begotten of the Spirit, we, as new creatures, enter the holy or spirit begotten condition, where, as indicated in the type, we have all the light of the various stages of the Church as indicated in the golden candlesticks, one after another having been lighted till now all seven are shining upon us. We are privileged both to feed upon the unleavened bread, the Word, and, as the golden table, to hold it forth to others who enter the Holy. We therefore have that which the Jews, with all their zeal towards God, so sadly lacked, and that is, knowledge, knowledge of God and of His will concerning us. It was the knowledge of Jesus as well as His perfect ability which enabled Him to offer upon the golden altar the incense representing the perfections of His Being. The fire was from the brazen altar and meant the same in the holy as in the court or outside the camp, sufferings, trials, consuming, and the crumbling of the incense upon it represented the patient, continuous submission of His perfect being to the sufferings and trials which his own course of loving obedience brought upon Himself. It was here, in the spirit-begotten condition that the apostle says of Jesus, "though he were a son, yet learned He obedience in the things that He suffered." It was here that He demonstrated to the Father not only that he was dead to self-will and dead to the world, but that he was "alive unto righteousness," or as He Himself said, "I do always the things that please Him." He had learned well the lesson in which king Saul failed, that "obedience is better than sacrifice and to hearken unto the Word of the Lord than the fat of rams" (1 Sam. 15:22).

Therefore he could say to the Father, "I know Thou hearest me always" for the incense from the sacrifice of obedience to the Father's will preceded him into heaven itself and was not merely a "sweet savor" but an "odor of a sweet smell," a delightful perfume to God. Similarly we, though having nothing really perfect to offer, may through our High Priest offer our perfection of intention and demonstrate our loving obedience and loyalty by a patient and continuous submission to the sufferings and trials which must be brought upon ourselves by our own course of faithfulness.

For like our dear Lord and Head we say, "I delight to do Thy will, O my God, thy law is within my heart" (Psalm 40:8); so we become followers of Him.

To review, then, dear brethren, we saw in the fire in the court a picture of the sufferings and trials with which our loving zeal and self-denial bring us into contact; in the fire outside the camp those which our loving sacrifice and cross-bearing bring upon us; and the fire in the Holy those which our loving and enlightened obedience cause us to suffer. We concluded then that all three fires constitute one complete sacrifice, that each one is necessary, but the best and most valuable of all, the loving obedience whose incense precedes the church into heaven itself. Let us remember that "if we suffer, we shall also reign with Him" (2 Tim. 2:12); and as Paul wrote to the Corinthians (2 Cor. 1:7), I want to add to you, "Our hope of you is steadfast, knowing that as ye are partakers of the sufferings, so shall ye be of the consolation." We will therefore look unto Jesus, who for the joy set before Him endured the cross and despised the shame.

## **7:30 P.M. - Discourse**

*by Brother A. E. Burgess.*

### **Study to Show Thyself approved Unto God**

Our Topic: Study to Show Thyself approved Unto God, a Workman that Needeth Not to be Ashamed, Rightly Dividing the Word of Truth." (2 Tim. 2:15)

THERE are four prominent thoughts suggested by this text which I desire to bring to your attention this evening.

#### **STUDY.**

We all doubtless recognize the value of study in connection with various earthly pursuits. If, for instance, any of us desire to become an accomplished musician, we must apply ourselves diligently to the study of music. We know that it is necessary to gain a knowledge of the principles and rules governing in music in order that we may become proficient in that profession. In undertaking to learn various languages or a trade of any kind we know that we



Brother A. E. Burgess.

must get certain rules and principles fixed in the mind in order that we may intelligently apply ourselves to the work in hand. This is also true in the ourselves to the work in hand. This is also true in the study of the divine science. If we seek earnestly, diligently, perseveringly to know what the will of God is, we are assured that we shall find. If we knock at the door of divine wisdom, "seek for her as for hid treasure," the mysteries of God's wisdom will be opened unto us, for God has declared in His word that "The secret of the Lord is with them that fear Him and He hath covenanted to show it unto them." It is "to those who by patient continuance in well-doing seek for glory, honor and immortality" that the promise of eternal life is assured. If we expect to win God's favor by taking a glance now and then at His Word, merely for the sake of satisfying our conscience that we are in a small measure

at least in touch with the Lord, we will surely fail of being approved of Him. If we imagine, as some do, that there is enough in the 5th, 6th and 7th chapters of Matthew to save any man, without considering any other portion of God's Word we will be neglecting His instructions and casting His words behind us, for the apostle declares that "All Scripture given by inspiration of God is profitable for doctrine, reproof, correction, and instruction in righteousness that the man of God may be perfect, thoroughly furnished unto all good work" (2 Tim. 3:16.)

If we take the standpoint of "Higher Criticism," "Modern Scholarship," etc., in their endeavors to dissect the Word of God and bring discredit upon all the Holy prophets and mouthpieces of God we cannot expect to learn of Him and His divine plan.

For instance, they declare that the book of Isaiah was written by different writers and not by Isaiah himself, that from the 39th chapter the style of writing is different, thus proving that more than one person had a hand in the writing of it though the apostles mention no less than ten different times passages occurring in the 40th, 42nd, 53rd, 61st and 65th chapters giving Isaiah the credit of uttering them.

It is claimed by modern scholarship that the book of Daniel was written, not by Daniel, but about 168 B.C. under the persecution of Antiochus Epiphanes. That it is not found among the Hebrew Prophets. That a classification of Israelitish worthies made 200 B.C. makes no mention of Daniel, and therefore for these reasons we should reject it as uninspired and unsuitable in our study of the divine science. They claim, moreover, that Daniel, being Apocalyptic literature, may possess some of the prophetic element, but it is neither doctrinal nor historical, and is too highly figurative to serve as a basis of a doctrine or the description of a special dispensation, and that its special use consists in that by means of these visions encouragement could be carried to those who were able to understand the figures, while if it fell into the hands of enemies it was useless to them, etc., etc.

Let us search the Scriptures, let us see what they tell us on these important points.

The prophet Daniel is mentioned by the prophet Ezekiel in company with two others, Noah and Job (Ezek. 14:14), and again in chapter 28:3, as being a criterion for wisdom. Are we going to accept the inspired record of God's Word or the babblings of science falsely so-called -- Higher Criticism?

Our Lord in His notable prophecy of the Matt. 24 specifically mentions the words of the prophet Daniel as worthy of special attention, saying "When ye therefore shall see the abomination of desolation, spoken of by Daniel, the Prophet, stand in the holy place (whoso readeth, let him understand)" showing that these words were to be carefully heeded by the Lord's children and serve as a means of information when the proper time came, and this prophecy referred to by our Lord as yet future should effectually protect us from the error of imagining that these words were only for the special use of the Jews in periods of persecution. But the apostle effectually shows that these things were not particularly written for them, for their instruction, but that they were written for ours (the Church's) instruction, saying "Whatsoever was written aforetime was written for our learning, that we through patience and comfort of the Scriptures might have hope." That Daniel himself and the Jews did not understand the meaning of these visions is

manifest by Daniel's own words and the answer of the angel to him (Dan. 12:8, 9). "And I heard but I understood not: then said I, O my Lord what shall be the end of these things?" and the answer was, "Go thy way, Daniel: for the words are closed up and sealed till the time of the end." Thus Daniel was not given to understand the vision which was not for him or for any to understand until the time of the end, until the Lord's due time for revealing the matter, and this is confirmed by the words of the Apostle Peter, concerning the salvation of the Church and what was written by the prophets (1 Peter 1:10-12). "Of which salvation the prophets have enquired and searched diligently, who prophesied of the grace that is to be brought unto you.

"Searching, what or what manner of time the Spirit of Christ which was in them did signify, when it testified beforehand the sufferings of Christ and the glory that should follow. Unto whom it was revealed that not unto themselves, but unto us they did minister the things which are now reported unto you by them that have preached the gospel unto you with the Holy Spirit sent down from heaven: which things the angels desire to look into."

Moreover the angel warned Daniel, saying, "Many shall be purified and made white, and tried; but the wicked shall do wickedly and none of the wicked shall understand; but the wise shall understand." Are we going to be wise toward God, and take the inspired testimony of the Lord and the apostles and the prophets and accept these Scriptures as the Word of God or are we going to taketh speculations and vain philosophies of science falsely so-called and of the wise of this world, whose wisdom the Lord declares He will bring to naught. Those who have become wicked from the divine standpoint not wicked in the sense of being the divine standpoint, not wicked in the sense of being immoral, or criminal, but in the sense of casting the words of the Lord behind them and allowing the wisdom of this world to blind their minds to the blessed truths of the Scriptures. "Take heed, brethren, says the apostle, lest there be in any of you an evil heart of unbelief, in departing from the living God (Heb. 3:12), and departing from the living God means departing from His words, which He has caused to be written for our admonition." But I trust, dear friends, this will not be so with any who are gathered here this evening, but that we all are of those who believe the apostle when he says, "All Scripture is given by inspiration of God and is profitable for doctrine, for reproof, for correction, for instruction in righteousness: that the man of God may be perfect, thoroughly furnished unto all good works" (2 Tim. 3:16-17); and let us remember, too, the apostle's words, 2 Peter 19:21: "We have also a more sure word of prophecy; whereunto ye do well that ye take heed, as unto a light that shineth in a dark place until the day dawn, and the day star arise in your hearts," etc.

It will not be sufficient therefore that we possess a Bible, have one on our center-tables, and occasionally glance into it. We cannot expect to grow in grace and in the knowledge of our Lord Jesus Christ by this means. "Study to show thyself approved," says the apostle, and in no other way can we become approved of the Lord and gain an insight into the deep things of God, which He assures us have been reserved for them that love Him."

In taking up a study, as arithmetic, for instance, it is necessary that we procure a text-book containing principles which are to be brought into operation, and which contain the instructions necessary for the application of these rules. The rules to be applied in the working out of certain problems are given and then illustrations and examples of the application of these rules follow.

So also in the study of divine science -- the Heavenly Wisdom -- we have our text-book, the Bible, which contains all the rules and principles necessary for those who desire to learn of God and be found approved of Him. As the apostle declares, "The Holy Scriptures are able to make thee wise unto salvation through faith which is in Christ Jesus." All Scripture, etc. (2 Tim. 3:15, 16).

But another thing is requisite in our study of arithmetic. We may have the desire and determination to learn, and we may also have the text-book, but we will find the study and application of the principles for the working out of the problems difficult indeed, unless we have an instructor, a teacher, a helper, who has already obtained a knowledge of the principles and rules of arithmetic and how to apply them.

### **Teacher Necessary in Studying the Scriptures.**

This is true also in the study of the Scriptures; it is necessary that there be teachers or instructors who, by knowledge and experience, can instruct in the quickest and best way of learning the principles of righteousness and how to apply them.

The great head teacher or principal in this school is our Heavenly Father Who needeth not to have anyone teach Him, for He established His own laws and knows all about them. As the prophet Isaiah declares "Who hath directed the Spirit of the Lord, or being His counsellor hath taught Him? With whom took He counsel, and who instructed Him, and taught Him in the path of judgment, and taught Him knowledge and showed to Him the way of understanding?" (Isa. 4:13, 14). It is He who has given us our text-book, the Bible, as the Lord Himself declared "It is written in the prophets, and they shall be all taught of God" (John 6:45).

Our Lord Jesus is the great teacher and instructor under the Father who has been given charge of the instruction of the Church "That He might sanctify it and cleanse it with the washing of water by the Word, that He might present it unto Himself a glorious Church, not having spot, or wrinkle or any such thing; but that it should be holy and without blemish." For this reason our Lord Himself received instructions in the principles of righteousness and in the laws which the Father laid down for the government of all His creatures and therefore our Lord was instructed and brought through experiences in the application of these principles which would enable Him to be a suitable teacher and instructor of the Church and all mankind. As the apostle says, "Wherefore in all things it behooved him to be made like unto his brethren, that He might be a merciful and faithful high-priest in things pertaining to God, to make reconciliation for the sins of the people. For in that He Himself hath suffered being tempted, He is able to succor them that are tempted (Heb. 2:18)" and again, "Though He were a son, yet learned He obedience by the things which He suffered; and being made perfect (in this lesson of obedience) He became the author of eternal salvation unto all them that obey Him (Heb. 5:8, 9)."

But the Scriptures inform us that there are under teachers and instructors which have been ordained of God for the perfecting of the saints and for the instruction of the Church. When He was about to depart from this world He informed His disciples that a teacher would be sent them who would represent Him in the world, saying, "Howbeit when He, the Spirit of Truth, is come, He will guide you into all truth: for He shall not speak of Himself; but whatsoever He shall hear,

that shall He speak: and He will show you things to come. He shall glorify me: for He shall receive of mine and shall show it unto you." This holy spirit is therefore represented as the means or channel by which the Church is to be instructed during the present gospel age, and it operates in and through the Lord's consecrated children for "Know ye not that ye are the temple of God, and that the Spirit of God dwelleth in you?" (1 Cor. 3:16).

Wherefore he saith, "When He ascended up on high, He led captivity captive, and gave gifts unto men. And He gave some apostles; and some prophets; and some evangelists, and some pastors and teachers; and these teachers or instructors are given, not for the converting of the world, not for conquering the world for Christ during the present time and under the present conditions, but "for the perfecting of the saints, for the work of the ministry, for the edifying of the body of Christ: Till we all come in the unity of the faith, and of the knowledge of the Son of God, unto a perfect man, unto the measure of the statute of the fullness of Christ" (Eph. 4:8, 11, 12, 13).

These teachers, etc., do not gain their opportunities of service in connection with the Church by means of apostolic succession as some have claimed, which is not authorized of God, but consists of the claims of man, but rather the true teachers, pastors, and evangelists are ordained of God, are called of Him, are anointed or begotten of His Holy Spirit, are used of Him to the extent of their abilities for the service of the Church, for its growth and development, as the apostle says, "But now hath God set the members every one of them in the body, as it has pleased Him" (1 Cor. 12:18).

In Rev. first chapter is shown the care of the Lord for His Church and the provision made by the Heavenly Father for her instruction, and the method or means whereby it is imparted. Rev. 1:12. The Revelator describes how he saw in vision seven golden candlesticks; and in the midst of the seven golden candlesticks one like unto the Son of Man. \* \* \* \* And he had in his right hand seven stars: and out of his mouth went a sharp two-edged sword: and his countenance was as the sun shineth in his strength. It is out of our province to examine into the meaning of these symbols except with those which refer particularly to our subject, and so we content ourselves with these. The words evidently refer to our Lord Jesus Christ Himself in His present condition as a glorious spirit being raised far above angels, principalities and powers and every name that is named. And he proceeds to explain some of these symbols, saying to the Revelator, "The mystery of the seven stars which thou sawest in my right hand, and the seven golden candlesticks. The seven stars are the angels of these seven churches; and the seven candlesticks which thou sawest are the seven churches." The number seven as used in the scriptures, seems to signify a perfect number of the whole of that which it relates to, and therefore with this understanding the seven candlesticks would represent the Church as a whole down through the gospel age and the fact that the Lord is represented as standing in the midst would signify that He is present with His Church, to instruct, to assist, to guide her, fulfilling the promise which He made to His disciples just before His ascension, "Lo I am with you always, even unto the end of the Age." And He has been with His Church (not in person, for we are told that the Heavens must retain Him, until His second coming, until the times of restitution of all things, etc., Acts 3:21) but representatively present in the Holy Spirit which represents the power of God and His power operating in the hearts of all his consecrated children and also in the hearts of those whom the Lord has chosen down through the age to specially assist and help and instruct His Church, which seems to be signified by the fact that there was represented in His right hand (symbol of

power) seven stars which are "the angels (messengers) of the seven churches," and the fact that the Lord has had these angels or messengers in the Church all down the age is shown not only by the scriptures but also by the history of the Church for do we not find that though the thick, dense darkness of the dark ages had settled upon the Church bringing superstition, fear, false doctrines, and a mass of human traditions which obscured God's Word, nevertheless He raised up angels, messengers or reformers such as Luther, Calvin, Knox, Wycliffe, the Wesleys who assisted His truth-famished saints, rescued some of the gems of truth from the rubbish that had accumulated over them and brought blessing and refreshment to the saints, indicating to them that their Lord had not forgotten them but was mindful of their interests and at the proper time would give them the needed succor.

### **Meat in Due Season.**

And so we find that now according to his promise the Lord has His angel, His messenger, His consecrated servant through whom He is pleased to render that assistance to His saints which is needed at the present time, when infidelity, and skepticism, and deceptions of various kinds are being promulgated by the great Adversary to deceive and delude the thoughtful and intelligent who are shaking themselves loose from the ignorance and superstition of the past and find the doctrines promulgated during the dark ages, too repulsive, absurd and unreasonable to be entertained any longer, being utterly unable to harmonize them with reason, and common sense and the merciful, loving, just character of our God which is represented in the Scriptures. And so now we have this help, this meat in due season, to the household of faith in the shape of a series of Scripture Studies which have brought joy and gladness and refreshment to many a truth-hungry individual groaning in darkness and uncertainty and doubt, and longing for the light of God's blessed truth to shine upon his soul. The Psalmist also confirms this by saying (Psa. 91:11, 12) "For He shall give His angels a charge over thee, to keep thee in all thy ways. They shall bear thee up in their hands lest thou dash thy foot against a stone."

But there are many who do not see how the Lord is dealing in this way and instead of recognizing His angels, His messengers, they reject these and say we do not want your Bible Studies, your Bible helps; we study the Bible for ourselves. God teaches us and we do not want any of man's theories. We are heartily in harmony with this last statement of theirs, but they do not realize how unreasonable is their position when it is closely examined, and so completely does this erroneous thought take possession of their minds that they ultimately come to lay aside the text-book that God has provided, the Bible itself, and claim that they have now got beyond its teachings, and now have some inward, mysterious spirit whisperings, the voice of God direct instructing them what to do, and how they may become approved of Him.

I had an experience along this line a few months ago, having the opportunity of speaking with a gentleman who claimed to be a Bible student. I recommended the series of Scripture Studies published by the Watch Tower Bible & Tract Society, as very effective helps in the study of the Scriptures, to obtain a knowledge of the plan of God and a higher and grander and better understanding of the character of God and the lengths and breadths and depths and heights of His love. He answered me that he did not want them as he studied the Bible himself and did not wish to take man's theories for his guidance. I replied, "that I appreciated his desire to keep close to the Word of God and accept what it teaches only, but attempted to point out that we needed some

assistance in our study and that God used various means and instrumentalities in instructing us in His Word," and furthermore, I said, "My friend, do you not study the Bible with the hope of gaining a knowledge of the plan of God and the salvation which He has provided and do you not tell the result of your study to others so that they may be instructed and blessed?" He replied in the affirmative. I answered, "Then, my friend, what is the difference in your studying the Bible and telling the result of your study to others and in writing the results of your studies and having them published in book form?" Might not those whom you are endeavoring to tell your ideas say, "Those are only man's ideas and we want none of them, they are only your ideas, etc., etc." He was forced to admit that this was so and that the principle of the matter was no different but he was not sufficiently influenced to act in harmony with that conclusion. But we have the Scripture evidence that something more is necessary than the desire and determination to learn and the possession of the text book the Bible. In Acts 8:26-36 we read how that Philip was directed by the Spirit of the Lord to go down into a certain place and there he found an Ethiopian eunuch of great authority sitting in his chariot and reading the prophet Isaiah. Here we see this Ethiopian had the prophet Esaias, a part of the text book and was reading it or studying it presumable because he thought he could learn more concerning the only true God from it. "And Philip ran to him and said, Understandest thou what thou readest? And he said, How can I, except some man would guide me? And he desired Philip that he would come up and sit with him." Here the eunuch recognized that something more was necessary than merely the text book. He needed a teacher, an instructor, who had already learned the principles and how to apply them and who could instruct him how to understand the matter contained in the prophecy. The place of the Scripture which he read was this, "He was led as a sheep to the slaughter; and like a lamb dumb before his shearer, so opened He not His mouth, etc." "And the eunuch answered Philip, and said, I pray thee, of whom speaketh the prophet this? of himself, or of some other man?" Here we see the need of the man who though having the text book and the determination to learn yet needed some assistance in getting at the truths contained in the book, and the Lord ever mindful of those who are feeling after Him if haply they may find Him set the needed assistance in the person of Philip. "Then Philip opened his mouth, and began at the same Scripture, and preached unto him Jesus." And as a result of this preaching the eunuch was led to believe in the Lord, was baptized and thus becoming a member of the Church of God, receiving His Holy Spirit, he doubtless went his way to teach and assist in turn others who would be inclined to seek after the Lord. And thus has the Lord dealt with His Church down through the Gospel Age giving them the needed assistance in due time and raising up teachers and instructors and helpers to give them meat in due season.

### **Approved of God.**

But a very important consideration now demands our attention. The apostle says, "Study to show thy self approved unto God." Ah, yes! how necessary to consider the approval of God. How much studying there has been to be found approved of men instead of approved with God. And what a snare has this spirit been unto the Church. Truly did the Lord say "How can he believe, which receive honor one of another, and seek not the honor that cometh from God only?" It was on account of this seeking honor from one another and from men on the part of those who professed to be God's children that brought the period known as the "dark ages" upon the Christian world, and this was in harmony with what had been foretold by the Spirit through the Apostle Paul in his words to Timothy, saying "Now the Spirit speaketh expressly, that in the



latter times some shall depart from the faith, giving heed to seducing spirits, and doctrines of devils, speaking lies in hypocrisy; having their conscience seared with a hot iron." And again, "For the time will come when they will not endure sound doctrine; but after their own lusts shall heap to themselves teachers having itching ears; And they shall turn away their ears from the truth, and shall be turned unto fables." And how exactly these words of the Apostle have been fulfilled is attested by history in the following extract from Lord's "Old Roman World." After showing the condition of the Church in the first century and the gradual change which came over it in the succeeding centuries up to the fourth, he then says: "The clergy, ambitious and worldly, sought rank and distinction. They even thronged the courts of princes and aspired to temporal honors. They were no longer supported by the voluntary contributions of the faithful, but by revenues supplied by the government, or property inherited from the old (pagan) temples. Great legacies were made to the Church by the rich, and these the clergy controlled. These bequests became sources of inexhaustible wealth. As wealth increased and was entrusted to the clergy, they became indifferent to the wants of the people, no longer supported by them. They became lazy, arrogant and independent. The people were shut out of the government of the Church. The bishop became a grand personage who controlled and appointed his clergy. The Church was allied with the state and religious dogmas were enforced by the sword of the magistrate." We might go on multiplying Scriptural and historical testimony on this point but we have quoted sufficient to establish the fact that there has been much studying on the part of the Lord's professed children to show themselves approved unto men rather than God, and it is to this fact that we find the Christian world and the so-called Christian Churches in the confusion doctrinally and spiritually in which we see them today, finding themselves spiritually starved, with their denominational tables full of repulsive and loathsome food (false doctrines of eternal torment, etc., etc.), and lamenting with the oft repeated cry "How can we reach the masses," and imbued with the false hope, the false idea that the Lord has commissioned the Church at the present time and under the present conditions to convert the world for Christ, they find with all their efforts that they cannot cope with the wave of infidelity and skepticism and heathen darkness which is increasing on the human race to an alarming extent. But those who study to show themselves approved of God, who listen to his instructions, whose hearts are open and desirous to receive his truth rely on his promise that "My word that goeth forth out of my mouth shall not return unto me void, but it shall accomplish that which I please and it shall prosper in the thing whereto I sent it." There have been taught what to hope for, what to pray for "Thy Kingdom come, Thy will be done in earth as it is in heaven." These true saints, children of God have been instructed and helped and assisted by the teachers and instructors the Lord has provided for His Church during the present time who are studying and have studied to show themselves approved unto God rather than men.

As a good teacher or instructor in arithmetic does not make the rule or principles, does not alter them, but abides by the text book and is merely but a help or assistant in learning them and the application of them, so it is important in the study of the divine law that we have teachers who will abide by the Word and whose instruction will be in harmony therewith and will tend to bring out the precious truths contained in it. This was true of our Lord who declared saying, "I can of mine own self do nothing; as I hear, I judge; and My judgment is just; because I seek not mine own will, but the will of the Father which hath sent Me." John 5:30. Our dear Redeemer recognized the fact that the Father had established the laws, and his instructions are to be followed implicitly.

We are also informed that the Holy Spirit would not speak of itself but "whatsoever he shall hear, that shall He speak; and He will show you things to come. He shall glorify Me; for He shall receive of Mine, and shall show it unto you. All things that the Father hath are mine." This same disposition was manifested by the Apostles as Paul declared "Not that we are sufficient of ourselves to think anything as of ourselves; but our sufficiency is of God; Who also hath made us able ministers of the New Testament." 2 Corinthians 3:5, 6. And speaking to Titus the Apostle shows the proper attitude to be preserved by all those who would be used of the Lord as teachers, instructors, helpers in His Church, saying, "For a Bishop must be blameless, as the steward of God; not self-willed, not soon angry, not given to wine, no striker, not given to filthy lure; but a lover of hospitality, a lover of good men, sober, just, holy, temperate; holding fast the faithful Word as he hath been taught, that he may be able by sound doctrine both to exhort and to convince the gainsayers." Ah! says one, does not this text say that a Bishop must "Hold fast the faithful Word as he hath been taught" and does not this mean that a Bishop taught in the Methodist faith, or the Presbyterian faith, or the Lutheran faith or the Catholic faith, should not search any further because he has been brought up and taught in either of these systems of faith and therefore must accept them as infallibly true and from which he dare not depart? We answer No, for we notice that the text reads, "Holding fast the Faithful Word," which would signify God's Word, God's Truth, God's teaching and not man's word or man's teaching or the teaching of creeds instituted by man. The revised version renders the text thus "Holding to the faithful word which is according to the teaching," which would bear out the same thought and signify that a Bishop who would be approved of God would be one who studied to show himself approved of God, who teaches the true words of the Lord and His Apostles -- "The faith once delivered to the saints," instead of another Gospel or Gospels, systems of faith, creeds of men originating during the dark ages, misrepresenting God's character and plan, and subverting the faith of many, who are, as a result of these God-dishonoring doctrines falling into infidelity and present-day deceptions.

But while it is necessary that the teachers, the instructors of the Church should see to it that they hold fast to the faithful word or teaching and teach only those things which the Lord directs, but it behooves also those who hear to be very alert concerning what they receive as truth. Well did our Lord say, "Take heed how ye hear" (Luke 8:18) and he would have all of His children realize the importance of proving all things and holding fast to that which is good. We remember how the Apostle Paul commended the noble Bereans for searching the Scriptures daily to see whether the things that were told them were so or not, and again the beloved Apostle John says, "Beloved believe not every spirit (doctrine, teaching) but try the spirits (doctrines, teachings), whether they be of God," and then he goes on to show that any teaching which makes void the foundation principle of Christian faith, the ransom, is not of God but is the spirit of the Antichrist, and should not be entertained by those who would be pleasing unto Him. And thus He gives a means to His people of testing all those who claim to be teachers and there is a responsibility on each one of us to see to it that we hear, recognize and appreciate only those teachings which are in harmony with, and authorized by the Word of God, and that we reject all that is inconsistent with this Word and dishonoring to the character of our God.

### **A Workman that Needeth Not be Ashamed.**

We have seen how very important study is in connection with the word of God, but all the studying we may do will be of no value to us unless we put into practice the results of our study. We may be entirely satisfied of the truth of those principles of righteousness which we have learned which constitute the "faith once delivered unto the saints," but unless we have also the spirit of obedience and work in accordance with those principles we will not be found approved of God. "Faith without works is dead, being alone," said the Apostle.

We find this principle operating in earthly pursuits for in taking up a line of study or a profession, it is well known that a theoretical understanding is not sufficient but it needs a practical understanding of the operation of certain principles and this is only to be obtained by working in accordance with the rules which we have studied.

The Apostle declares that "We are God's workmanship, created in Christ Jesus unto good works which God hath before ordained that we should walk in them (Eph. 2:0)," and he declares moreover that we have the privilege of laboring together with God, co-operating with Him in the work of building up characters which He can use for the great work of blessing the world which He has designed in His plan. He declares: "For we are laborers together with God; ye are God's husbandry, ye are God's building." He then points out that having accepted and recognized the proper foundation of faith, our Lord Jesus Christ, it is necessary that we should work to build up a superstructure of faith, a character in harmony with the principles of His divine law.

The Scriptures show us that there are workmen of two principal kinds -- workmen who "work the works of God," bringing forth fruit unto the honor and glory of God, and workmen who work the works of the flesh and of the devil, bringing forth fruit unto the dishonor of God, His character, His plans, and His Word. Some of the workmen of both classes are active, energetic, and zealous workmen, and some are of the lazy, indifferent, easygoing kind. It is therefore necessary that those who would be workmen that need not be ashamed should see to it that their work is in accordance with God's instructions, should be sure that they are working the works of God and not the works of the flesh and of the devil.

The importance of having our work of the proper kind is made evident by the words of the Lord in Matt. 7:21. "Not every one that saith unto Me, Lord, Lord, shall enter into the kingdom of heaven; but he that doeth the will of my Father which is in heaven." He shows that when the working of the Church during this age shall be reckoned up, when the judgment of the Church shall be manifested as to who are worthy and who are unworthy that there will be some who claim to be Christians, claim to know the Lord, claim to be doing His work, will not be recognized of the Lord as workmen who need not be ashamed of their work, saying "Many will say to me in that day, Lord, Lord, have we not prophesied in Thy name? and in Thy name have cast out devils? and in Thy name done many wonderful works? And then will I profess unto them, I never knew you (never approved of you or your works), depart from me, ye that work iniquity."

And so we find now at the present time many who are naming the name of Christ, who call themselves Christians are endeavoring to do what seems to themselves "many wonderful works"

in the name of Christ, and for the evangelization of the world which from the light of the truth which is now shining on the pathway of the righteous, shows that these works are not such as are approved of the Lord. Many who claim to be Christians and who would feel very indignant if they were called otherwise, nevertheless deny the Lord in their doctrines and in their works accepting the speculations of "science, falsely so-called, higher criticism, and skepticism, which deny the ransom, the very foundation principle of Christianity, bring discredit on the Word of God," and subvert the faith of many who are deceived by these speculations.

We have shown before how that a lack of proper study on the part of the Church has resulted in the dark ages wherein arose many false doctrines and false teachers who instead of waiting the Lord's time for the establishment of His kingdom have conceived the idea that the Church was commissioned to convert the world for Christ during the present time that Christ is not reigning and has been reigning since Pentecost, and that His Kingdom will be fully come when all the world shall have been converted to Christ, and those who refuse to obey during the present time will have their portion in eternal torment forever and ever. But the falsity of these hopes is demonstrated not only by the Scriptures but by facts themselves, for reliable statistics show that the proportion of births among the heathen who know not God as compared with the number who are being converted to Christianity is much greater at the close than at the beginning of the last century, and if this be true the hope of the Church in converting the world will never be accomplished.

But these false hopes are the result of a failure to

### **"Rightly Divide the Word of Truth,"**

the 4th principle thought suggested by our text. The importance of rightly dividing the Word of Truth can only be appreciated by those who have studied to bring forth proper works, those who are learning in the school of Christ, for these realize as we have shown before that if we desire to utilize our energies in a way which will give us the best results we must study to obtain a knowledge of the principles governing in any pursuit we undertake and so the Apostle Paul declared "I therefore so run, not as uncertainly; so fight I not as one that beateth the air." 1 Corinthians 9:26.

We have been accused of taking a Scripture here and a Scripture there and making them fit our particular idea and plans, by some who fail to discern the necessity of rightly dividing the Word of Truth, and we often hear the statement made that "you can prove any doctrine you like by taking disconnected passages from the Bible," and "The Bible is an old fiddle upon which any tune can be played," but these statements are not true, for any doctrine cannot be proved from the Bible, for let us remember that any doctrine that does not recognize the Scriptures as a whole, and while apparently being supported by one or two or more Scriptures, yet contradicts other Scriptures of equal authority is not thereby proved to be a true Scriptural doctrine, as the Apostle Peter declares "No prophecy of the Scripture is of any private interpretation." (i.e. is not to be interpreted by itself alone without reference to other Scriptures). For the prophecy came not in old time by the will of man; but holy men of God spake as they were moved by the Holy Spirit." 2 Peter 1:20, 21.

If we recognize the whole Scriptures as the Word of God and profitable for doctrine, reproof, etc., we must recognize the fact that it will reveal a plan of salvation which will be harmonious in all its parts, a plan which will not cause the statement of one Scripture text to contradict that of others but will harmonize all Scriptures from Genesis to Revelation, and unless we have such a doctrine, such a system of faith we cannot be assured that we have the truth -- "the faith once delivered unto the saints."

But the claim that we should not use a Scripture here and a Scripture there for the purpose of making plain the plan of God is false reasoning and contrary to the example of the Lord and the Apostles, for did not our Lord again and again refer to certain passages from the prophets without reference to what came before or after them and did not the Apostles and those who wrote the history of the Lord refer again and again to the words of the prophets in various places to prove the fulfillment by our Lord of certain things prophesied? And did not the Apostles in the Acts and in the various epistles quote detached sentences from the Old Testament to prove and illustrate the teachings they desired to inculcate? If anyone doubt this let him look up the matter in the back of a teacher's Bible where a list is given of the passages of the Old Testament which are quoted in the New, and he can satisfy himself that this is true. We notice, however, that the utterances of one apostle and inspired writer when seen in their proper light do not contradict the utterances of others, and if they seem to do so, the fault is with the system of belief and not with God's plan or the writings of the Scriptures. The foregoing therefore is in harmony with the words of the Apostle Paul in 1 Corinthians 2:1, 13, "Now we have received, not the spirit of the world, but the Spirit which is of God; that we might know the things that are freely given to us of God. Which things also we speak, not in the words which man's wisdom teaches but which the Holy Spirit teaches; comparing spiritual things with Spiritual." In other words, comparing Scripture with Scripture. "Line upon line, precept upon precept, here a little, and there a little."

By seeking the harmony of this particular text with God's plan as a whole.

By noting the general character of the book in which the text occurs.

Some books, like Daniel, being partly historical, partly prophetic.

Some books wholly symbolic, as Revelations.

Some partly literal and partly symbolic as the Epistles.

Some almost wholly literal, as Eccles.

A few illustrations of the necessity of rightly dividing the Word of Truth will now be in order. It is necessary in studying the Scriptures to discern or consider whether a certain passage is literal or symbolic and this may be determined, by considering the context in which the text occurs, by praying to the Lord for guidance in the understanding of His Word; by comparing this Scripture with others which seem to have a bearing on the matter; by considering Scriptures which seem to be contradictory; and by seeking the harmony of this particular text with God's Plan as a whole. We find therefore that certain Scriptures are literal statements, and some are symbolic statements and should be so interpreted in order that the harmony of the whole may be discerned.

For instance Eccl. 1:4 declares, "One generation passeth away and another generation cometh; but the earth abideth forever."

This text occurs in a connection which seems to be wholly literal describing accurately present conditions as they exist in the world under the present reign of evil.

Another text which seems to be in harmony with this statement is the declaration through the prophet Isaiah, "For thus saith the Lord that created the heavens; God Himself that formed the earth and made it, He hath established it; He created it not in vain, He formed it to be inhabited." Isa. 45:18. These plain literal statements would scarcely harmonize with the teaching of some professed Christians to the intent that at the Lord's second coming to judge the world, this earth will be burned up with all who are in it except the righteous who will be caught up to heaven or who have heretofore died and gone to heaven, basing their claim on a literal interpretation of the symbolic statement of the Apostle Peter, where he declares, "But the day of the Lord will come as a thief in the night; in the which the heavens shall pass away with a great noise, and the elements shall meet with fervent heat, the earth also and the works which are therein shall be burned up. We note, however, that the Apostle would guard our minds from a literal interpretation of the symbolic language he is using here, by cautioning us to not interpret the word day literally in this connection, saying, "But, beloved, be not ignorant of this one thing, that one day is with the Lord as a thousand years and a thousand years as one day." 2 Peter 3:8-10.

Another illustration of the necessity of "rightly dividing the Word of Truth" is the use of the word "heavens" in the Scriptures. This word is used in three different ways in the Scriptures. In Genesis 1:20 we read, "And God said, Let the waters bring forth abundantly the moving creature that hath life, and fowl that may fly above the earth in the open firmament of heaven." No one surely will deny that this is a literal statement referring to this air or atmosphere which surrounds the earth, and yet to say that this is the heavens which is to be dissolved would necessitate also the burning up or destruction of this earth which the wise man declares "abideth forever."

In Isaiah 66:1 we read, "Thus saith the Lord, The heaven is my throne and the earth is my footstool." We could not reasonably expect that this Scripture is the heaven referred to by the Apostle Peter as being on fire and being dissolved, for it would be absurd to think of the Lord permitting evil in His throne or place of authority and therefore there would be no necessity of burning up the Lord's throne for the purpose of purifying it. And besides this is not heaven represented as the home of the righteous who our nominal Christian friends claim went there when they died, and if this be true would they not be suffering some punishment, and would not their bliss be interrupted by having their throne dissolved or burnt up? Who cannot see the absurdity of such reasoning.

But when we come to consider the heavens in their symbolic aspect we will recognize why the symbolic heavens should be burnt up and why the new (symbolic) heavens and new (symbolic) earth spoken of by the Apostle (2 Pet. 3:13) and the Revelator (Rev. 21:1) should succeed the former.

When we realize that the Scriptures use the word heavens symbolically to represent the present spiritual ruling powers of evil, Satan and his angels and his systems as he is called "the god of this world" and "the ruler of the darkness of this world" and that the symbolic earth would consist of human society organized as it is into various governments established upon a foundation of selfishness, full of evil works so that the wise man describing the condition of the

human race at the present time says, "So I returned and considered all the oppressions that are done under the sun, and behold the tears of such as were oppressed, and they had no comforter; and on the side of their oppressors there was power; but they had no comforter. Wherefore (says the wise man) I praised the dead which are already dead more than the living which are yet alive." Eccl. 4:1, 2. We can see the necessity of these being removed and the new heavens (God's Kingdom) ruling in righteousness under the whole (heavens) and the new earth (human society organized on a basis of live and righteous works only being tolerated) taking their place, while the literal heavens and earth remain as they are being neither wicked, nor evil but rather "very good." Thus by means of rightly dividing the word of truth we are enabled to harmonize otherwise conflicting Scriptures.

Moreover we have the two great conflicting doctrines of "Election" and "Free-grace" which have puzzled the minds of wise men of different denominations and proved a fruitful source of controversy in times past and at the present time. And yet those who teach these doctrines can apparently find abundant Scripture texts to prove their positions which has given rise to the thought that God's Word is contradictory and resulted in many turning to infidelity and skepticism. But "rightly dividing the Word of truth will harmonize these seemingly conflicting Scriptures."

"For whom he did foreknow, he also did predestinate to be conformed to the image of His Son, that he might be the firstborn among many brethren." (Rom. 8:29).

"Elect according to the foreknowledge of God through sanctification of the Spirit unto obedience and sprinkling of the blood of Jesus Christ." (1 Peter 1:2). Texts claimed by those teaching election.

"And the Spirit and the Bride say, Come. And let him that heareth say, Come. And let him that is athirst come. And whosoever will, let him take of the water of life freely." (Rev.2 2:17). Text claimed by Arminianism.

A right dividing of the Word of truth shows us that God has not been arbitrarily selecting a "Little Flock" to be saved and the vast majority to be eternally tormented, but rather has been selecting, trying, testing, an elect little flock to constitute His Kingdom or be associated with the Lord as joint-heirs with Him in the Kingdom of God for the purpose of blessing the vast majority and giving them a full, individual trial and opportunity for salvation under much more favorable conditions than prevail at the present time.

A right dividing of the Word of Truth prevents us from concluding that God though having the most benevolent intentions toward the human race, while congratulating Himself that the man whom He had created was "very good" had all His good work and good designs overturned by a master stroke of running on the part of Satan, and being desirous of recovering as much of the wreck as possible and save as many of the human race as possible from eternal torment, having been driven to the extremity of sending His only begotten Son into the world to die on behalf of all mankind, has been compelled as it were, to stand aside wringing His hands as He beholds the wrecking of all His plans, crying and pleading coaxing and cajoling, guilty sinners in the words so often used by evangelists, "As I live, saith the Lord God, I have no pleasure in the death of the

wicked; but that the wicked turn from his way and live; turn ye, turn ye, from your evil ways, etc.," endeavoring by this means to snatch as many as possible as brands from the eternal burning. But the earnest pleading apparently falls upon deaf ears and notwithstanding the most strenuous efforts put forth by himself and these so-called preachers of the Gospel in their endeavors to "save souls," he is able to extricate only a "little flock" from out of earth's millions out of the dire predicament into which they have fallen and save them from that eternal torment which we have been taught is in store for them.

Our dear friends, through a failure to study to show themselves approved unto God and thus to rightly divide the Word of Truth in their teaching that God has, ever since the fall of man, been extending His grace and mercy, full and free, to the intent that all, if they would might be saved. In other words, that God has been trying all through the past up to the present time to convert the world by various means, and that the present life and times ends all probation, are like a builder who undertakes to build a house, after laying the foundation, starts to build upon it what is intended for the second story, before he has started work in or completed the first story, for they are endeavoring to accomplish a work which is not intended by the Lord be undertaken until a previous part of God's plan is accomplished, of taking out a people for the name the Lord, bringing them through certain experiences which will fit them for the great missionary work of the future -- the blessing of all the families of the earth with a knowledge of divine grace and favor -- the awakening of the sleeping millions of the human race from the grace and helping, assisting, and lifting up the willing and obedient to all that was lost by father Adam's disobedience as the Apostle James declares in Acts 15:12-17, saying, "Men and brethren, hearken unto me: Simeon hath declared how God at the first did visit the Gentile to take out of them a people for His name. And to this agree the words of the prophets; as it is written. After this (after the selection of this Little Flock) I will return (referring to the second coming of our Lord in power and glory) and will build again the tabernacle of David, which is fallen down; and I will build again the ruins thereof, and I will set it up: **THAT THE RESIDUE OF MEN** (all those who during the present time have not heard of the only name under heaven given among men whereby we must be saved, those who are not of this elect class) **MIGHT SEEK AFTER THE LORD, AND ALL THE GENTILES, UPON WHOM MY NAME IS CALLED,** saith the Lord who doeth all these things."

We rejoice that the Lord has arranged in His plan for this glorious hope for the world, that though now "the God of this world has blinded the minds of them that believe not lest the light of the glorious gospel of Christ, who is the image of God, shall shine unto them" (2 Cor. 4:4) yet the Lord has provided in His plan that in due time, "In that day shall the deaf hear the words of the book (The Scriptures, containing God's plan) and the eyes of the blind shall see out of obscurity and out of darkness" (Isa. 29:18). For "then the eyes of the blind shall be opened, and the ears of the deaf shall be unstopped." (Isa. 35:5.)

And it is very important in order to rightly divide the Word of Truth that we realize that our study of the Scriptures is along two general lines," (1) Study and practical application of those Scriptures which pertain to the development of Christian character, and the exercise of the qualities of love, and (2) Study and practical application of those Scriptures which pertain to a knowledge of dispensational truth and God's dealings with the world of mankind in general, which will enable us to know what work the Lord is engaged in at any particular time, whether it



is a work of sowing the seed or of reaping what has already been sown, and thus we may be able to utilize intelligently whatever powers we have to use in the Lord's service, in harmony with his will, which will obtain the best results and thus we will grow not only in GRACE (character) but also in the KNOWLEDGE (understanding) of our Lord Jesus Christ and of the Heavenly Father's plans.

Some have been studying the Word along the lines of character development, that they may grow in grace and have measurably neglected the prophecies and the study of dispensational truth, and as a result like the Pharisees of old, who sent about to establish their own righteousness and did not submit themselves to the "righteousness of God" so these also "know not the time of their visitation" (Luke 19:44) and thus whatever works they undertake are more or less a beating of the air, expending energy and time and talent without accomplishing any material results.

On the contrary some make the mistake of studying prophecy and dispensational truth and neglect the work of character building which causes them to become spiritually lean and weak and tends toward pride and vanity, as the apostle says "Knowledge puffeth up but charity (love) edifieth." (1 Corinthians 8:1.)

But our time will not allow us to consider any more of the many illustrations of the value of rightly dividing the word of Truth but we trust sufficient has been presented to make the matter clear in the minds of all and if any are desirous to know the way of the Lord more perfectly and who are hungering and thirsting after righteousness, and to study to show himself approved unto God, a workman that needeth not to be ashamed, rightly dividing the Word of Truth," we would recommend to such an one a careful and prayerful perusal of the six volumes of Scripture Studies published by the WATCH TOWER BIBLE AND TRACT SOCIETY of ALLEGHENY, PA., at a nominal sum -- cost price -- and we feel sure it will be time and money well spent, and that as a result the individual will receive joy and blessing in his heart.

**SUNDAY, OCTOBER 6.**  
**9 A.M. - Praise and Testimony Meeting,**  
*led by Brother Steve Kendall,*

opened by singing No. 165: "Love Divine, All Love Excelling."

Prayer, followed by hymn No. 210: "One More Day's Work for Jesus."

Bro. Rutherford: We are rejoicing that we have the opportunity of working one more day for Jesus, and that we are one day nearer the Kingdom.

Bro. Mead, Boston: I stand before you this morning full of love for Christ. This convention has done me more good than I can ever tell you.

A brother: We have bumped against the real thing; it is not a dream. Our Savior Jesus is with us now, and is King of Kings and Lord of Lords. I hope this Convention will be a blessing, not only to ourselves, but to the whole country. Let us work with all our might and main. You have no idea what a blessing it has been to me.

Br. Read, of Chicago: I want to testify and say how much good the testimonies of the friends have been to me; I have enjoyed them very much. I am what I am by the grace of God. I am almost ashamed to say it, because I am so little, so weak, but if we will only let Him, He will do a great deal with us. I am what I am by His grace. I have received a great blessing and want to take some of it to others; I want to prove faithful to the end and ask an interest in all of your prayers.

Bro. Hall, Louisville: I want to acknowledge my Heavenly Father's blessings. The text that has impressed me is: "Be content with such things as ye have; for He hath said, I will never leave thee, nor forsake thee."

When we look back and see how God has led us over the rocks and stumbling stones, placed in our way, my heart is lifted up in thankfulness to our Heavenly Father. It is only through His kindness that I am here, not expecting to attend any convention for sometime, but He opened the way and gave me the blessings that I so much needed. Our Heavenly Father will never leave us nor forsake us. I can realize all the way that the Father's hand has upheld me and through faith in our dear Redeemer I have been able to keep hold of this grand truth.

Bro. Williams: I have the pleasure this morning of meeting with you in this place. I make it a point to tell the friends among whom I work, that we have a family reunion. Yesterday someone said we all looked alike. We all smile alike anyway. I am glad I could meet with so many here, for there are about seven hundred present and I am glad I have so many brothers and sisters. Even though I am tall, yet I need your prayers as much as if I were a little fellow. Pray for me that I may be faithful.

A colored brother: (This brother referred to the parable of the "pearl of great price" for which a man sold all he had so as to purchase it.) He said, I understand that this pearl will not be mine until I have made my calling and election sure, and before I can make my calling and election sure, I must have a great sale of all I have.

A brother: I know there are many dear friends who would like to be here and enjoy the blessings with us. A great many have attended this convention whose tickets have been limited; four had to return on that account. Now dear friends, a blessed thought to think about, when we have procured tickets tot hat Convention they will not be limited, but all will be allowed to remain at that Convention. I want to be one of the 144,000.

Bro. Hettenbaugh: My heart is overflowing; I have attended ten general conventions and this is the best one of them all; I want to be faithful.

Bro. Hollister: I testified in a colporteur meeting, but I forgot to bring the love and greetings to you from the St. Louis class, which I now extend to you.

I believe with Bro. Read, I am what I am through the Lord's goodness. While I feel my weakness, I do desire, above all things to be conformed to Christ's image. One particular passage, very precious to me; "Thou shalt love the Lord thy God with all thine heart, with all thy

soul and with all thy might." I have learned more and more that God is a God of love and is worthy of our greatest love.

Bro. Hughes, (North Carolina): I feel, dear brethren, it is good to be here -- what will it be to be over there? I stand up here to witness for Jesus who suffered and died for me. Pray that I may be faithful and true.

A brother: I am glad that I have been able to be here; my heart rejoices at this time. Although where I live, it is a very small town and there are but five or six interested, but the postmaster is in the truth and the assistant postmaster and the mail carrier and the squire is also in the truth; also the former squire who persecuted us a year ago, who said this literature should not go through the mails; he cannot get enough of it now.

A brother: The Heavenly father has given me the privilege of meeting with you. Before I got the truth I had only three brothers and sisters to live, but now dear friends how many I have!

A colored sister: I am not ashamed of the Gospel; it is so grand to think that there is no place of eternal torment. I was really scared about that place and did not want to go there, but now we know there is a great blessing for all. I thank God this morning that I have found the truth and that it has made me free. My text is: "Stand fast in the liberty wherewith God has made us free."

(Love seemed to be the keynote at all of these testimony meetings. This was the last praise and testimony meeting of the Convention; there were many other excellent testimonies, but on account of the large size of the room and the outside noise and weak voices of many, especially the sisters, the stenographers were unable to hear enough of them to include them in this report. However, we trust that enough have been reported to show the spirit that was manifested throughout the Convention.)

## 10:30 A. M. -- Discourse

by Pilgrim Brother Hayden Samson.

### Topic: "The Witness of the Spirit."

Brother Samson spoke, in substance, as follows:

The subject this morning is of deep importance to all consecrated people, and it is one that covers a great deal more ground than I could hope to cover in one discourse; I would rather have as many as three discourses on this subject, if opportunity permitted.



Brother Hayden Samson.

The text is in the 8th chapter of Romans, the 16th and 17th verses: "The spirit itself beareth witness with our spirit, that we are the children of God; and if children, then heirs; heirs of Christ; if so be we suffer with Him, that we may also be glorified together."

In the 7th chapter of Romans, which preceding the one from which I have taken the text, the Apostle is telling about the conflict he found waging within him after he had been begotten to the spiritual nature, through the Word of Truth. He speaks of the old man and the new man both dwelling in the one tenement of clay, the one coming into life, and the other reckoned dead. You remember in another place, he speaks of the body in the then present condition of a tenement, and of the two tenants. And he said that he did not desire particularly to be unclothed -- that is, not have any body in which the new spirit-begotten mind should dwell, because to be unclothed back there in his day, he would have no life at all; he would be dead and would have to wait until the first resurrection. But he did desire to be clothed upon with the better house from heaven, though he would rather have the old human body for a while as a tenement rather than to be entirely unclothed, and so he tells us again and again about this warfare waging to a greater or less extent between the two. Now I want to impress the thought I understand the Apostle to teach, --that he did not count the old man actually dead, but only reckonedly dead.

I do not know that I have heard this thought more clearly expressed than by Brother George Draper at the St. Paul Convention a year ago this Fall. He was telling us about the time when he withdrew from the Baptist Church of which he had been a very acceptable member. The Baptist minister came to labor with him, to set him right -- right in his own estimation, of course. Now, he said, I want to be faithful to you as your former pastor; I want you to take your Bible and sit down here with me, and we will read together and do a little studying together; I want to get you right about this matter; you are imbibing some very unscriptural and unsafe doctrines.

Very well, said Brother Draper. He said the minister was a good man and he appreciated his efforts, however misguided they may have been. Now, said the pastor, let us open our Bibles at the 16th chapter of the Gospel of Luke. I want to have a little discussion with you about that. You are altogether mistaken regarding the statement there concerning the rich man and Lazarus. I want to prove to you that it is not a parable, but a straight, literal statement.

Very well, said Brother Draper. They sat down together.

Now, the minister said, let me read: "The rich man died and was buried." You do not see anything like a symbolism or a parable in such a statement as that, do you? Is not that a very common every-day occurrence? Are not men dying every day and being buried?

Yes. Well now, when you are ready, go on and read some more.

"And in hell he lifted up his eyes --"

Hold on, now, said Brother Draper, if he lifted up his eyes he was not dead, was he? You never can make me believe that man was dead as long as he lifted up his eyes. And so, he said, in this case, I find the old man is only reckoned dead, because every now and then I find him lifting up his eyes pleading for indulgences, for ease, etc. -- things contrary to the spirit. And I have to do as Paul did, to put up a good, strong fight to keep my body under.

Brother Harrison, speaking a little along this line to us in the city of Scranton a few months ago, said, Take the old man and yoke him up and put him to work; keep him busy in the service of the new mind, and then we won't have so much trouble with him.

And then we find, dear friends, the new is coming into life if we are following on to know the Lord, while the old is only reckoned dead, and will actually die in due time. And so the Apostle, speaking further in this connection, said that having been begotten of the spirit, if we turn to walk after the flesh, to persist in such a course, we shall die -- lose all life entirely -- because we have consecrated the old for the express purpose of complying with the new conditions; but if we through the spirit do mortify the deeds of the body, then as spirit beings, we will live. Toward the close of the 7th chapter, still going on in the same strain, he cries out as though under the dominion of the old, -- "O wretched man that I am, who shall deliver me from this body of death?" And then triumphantly exclaims in the next verse, "I thank God through Jesus Christ our Lord." There is where we will get the deliverance. Then with the beginning of the 8th chapter, he says: "There is therefore now no condemnation to them which are in Christ Jesus, who walk not after the flesh, but after the spirit." This would naturally raise the question in our minds, What is the condemnation resting on the race of mankind? We read in the fifth chapter of that Epistle and in the 12th verse, -- "Therefore as by one man, sin entered into the world and death by sin; and so death (sentence) passed upon all men, in whom all have sinned." (See margin.) All sinned in the one man, their natural representative head, and they were sentenced in him. Further, in the 18th verse, we read, "Therefore by the offense of one judgment came upon all men unto condemnation." What did it condemn them to? The other verse has told us: it condemned them all to death. But here we turn to the 8th chapter of the same Epistle, and we read of a class that is free from all this condemnation. Well then, if this sentence of death passed upon all, and this class is free from the condemnation, why do they die? They do not die in Adam. They die with Christ a sacrificial death, justified to life through faith in His ransom; it is a consecrated death. Our Lord gave us His life in sacrifice. No man taketh my life from me; I lay it down. It is true also in a measure with those who receive Him as their Savior and Lord.

When our Lord was nearing the close of His public ministry, the cross was staring Him in the face, and we remember how He went into the garden of Gethsemane, and how He prayed there, "Oh My Father, if it be possible (consistent with Thy will and plan I understand it to be) let this cup pass from me." But it was made very clear to His understanding that it was part of the Father's plan that He should drink that bitter cup to its dregs if He would fulfill the Father's purpose and intention concerning the redemptive work, and he said "Thy will be done." He no doubt heard the tramp of the multitude coming to arrest Him, and having the victory in every sense, as implied in those four words, "Thy will be done," He met them at the gate and said, Whom seek ye? And they said, Jesus of Nazareth. Well, He said, I am the man, or words to that effect, and if you are seeking Me, let these go their way. Peter, however, heroically drew the sword in his Master's defense and struck a blow, but Jesus said to him, Peter, put up the sword, I could pray to the Father now and He would send more than twelve legions of angels, more than a hundred and forty-four might angels, if it were necessary to deliver Me from these Mine enemies, but then how should the Scriptures be fulfilled. We cannot see how they would be fulfilled. No doubt the Father had a way out, but we cannot see how they would have been fulfilled; neither did Jesus see how they would have been fulfilled. How, then, could the Scriptures be fulfilled if the Father had sent more than twelve legions of angels, when so far as Jesus, or we, could see it would have thwarted certain features of His plan? There must have been an all sufficient reason why the Heavenly Father could do that. What was the reason? I answer, Jesus had a right to human life on the human plane. We turn to the law covenant under which He was born and bred, and we read five times in the Old Testament, and repeated in the New, I gave them my statutes and judgments, which if a man do he shall live, -- not die. And Jesus did them, and had a right to life, and had He asked it of the Father, the Father would not have denied Him. Neither would He deny you, nor me, nor any other intelligent being his rights.

So we see that Jesus' death was a sacrificial death, "No man taketh my life from me." But we have heard again and again in this convention, and somewhat specially in the sermon by Brother Thomson, that "If any man will be my disciple, let him deny himself and take up his cross and follow Me," with the promise that "Where I am, there shall My servant be also -- eventually. Now, coming down to our text in the 8th chapter and 16th verse, "The Spirit beareth witness with our spirit that we are the children of God." Before raising the question as to what is the holy Spirit, I want to raise another question leading up to that thought. How does the spirit witness? I want to tell you first, dear friends, what I used to think about that matter, and what I now know about it. There is a great deal of difference. A good many years ago I was a very earnest member of the Methodist Church, and tried hard to be a very consistent one, and there were others, my associates, and we had some short seasons of peace, and then we would have some longer seasons of condemnation, and so it fluctuated -- condemnation and peace, and peace and condemnation, a good deal more of condemnation, however, than of peace. And we were very far from being satisfied with our experience. As a matter of fact, I can see now that we were not more than justified, if that. For I have never been able to see very clearly how a person can be justified by faith when his faith is based upon error and unscriptural doctrine. So I doubt if we were even justified back there. Well, we consulted with one another, for we were earnest, and I am glad the Lord took notice of our poor, feeble efforts back there, and in due time gave at least one of us the truth. Now if we could only settle this one question we would not have so much trouble, -- there is no condemnation to those who are in Christ Jesus, and the Spirit beareth witness with our spirit that we are the children of God. Now if we only knew how the Spirit bore

witness, then we would have the question settled as to whether we were children of God. If not, there must be some way whereby we could become children and get rid of this condemnation which so often occurred, and if we are His children, then the Spirit ought to bear witness to that fact and give us peace. It was finally suggested that when we are seeking to be true Christians and are happy, then the Spirit bears witness with our spirit that we are children of God because we are happy. Well, I was not satisfied with that explanation, though unable to offer a better one; therefore, I had to in one way accept it. I may say that at that time there was a sense in which I was, looking at it from a human or nominal church standpoint, a happy man. I was comparatively young in years, and had strong, robust health, could endure almost anything any other man could, had a very good home, a good situation, and a right good wife and two nice little children, and tried to serve the Lord. Of course there was a way in which I was, at least part of the time, happy. Well then, according to our theory, the Spirit was bearing witness with my spirit that I was a child of God. After a time, all of this changed, and the property was swept away to the very last dollar; and worse than that, a great debt left on my hands and nothing in the world to pay it with, only to work it out as best I could. There was no human law that compelled me to pay the debt, but it was an honest debt, and an honest man will pay his honest debts, no matter what the human laws are. I had the satisfaction eventually of paying every man to his entire satisfaction, to the uttermost farthing, and have his papers to show for it. Then sickness came into my family, and it was followed by cruel death. We buried two little children in one day, a little boy and little girl of almost four years; they died only five hours apart. And when I turned away from that grave, when the clouds began to fall, and looked into my poor wife's face, and our two oldest children's faces, then half grown up girl and boy as we say, and I saw the hot, bitter tears, I felt as though my own heart-strings were breaking, and from the depth of my soul I wished I had never been born to see such sorrow. According to our theory, the Spirit was not bearing witness with my spirit that I was a child of God, because I was not happy, but very unhappy indeed. A very unsatisfactory witness then indeed, for just at the time when I needed the witness of the Spirit most that I was a child of God was the very time that I did not have it at all, according to our theory.

How different all of this is now since walking in the light of Present Truth, and knowing both what the Spirit is and how it witnesses. I remember how some three or four years ago on my way towards New York City, I stopped to hold a meeting at Port Jarvis, and there I met an old associate who had been with me in revival work more than twenty years ago; in fact I had not seen him for eighteen years and did not know him when he came to the meeting. During the discourse I had occasion to speak of the time when I doubted, but now I know, and at the close of the meeting he rather took me to task for making so broad an assertion. He said that is too much for any living man to say, that he knows about these things. Well, I said, Brother Clark, I can tell you how I know, and picking up the Bible, I said, I know on the authority of this library, harmonized from the first of Genesis to the last of Revelation, and I know there is only one system of theology on this earth that can so harmonize this book, and I know that whoever has found that system and made it his own, has found one of the most priceless jewels that the Lord of heaven and of earth has yet given to any of His created intelligences. That is how I know. Then I doubted, but now I know.

As to how the spirit witnessed, -- in the case of the prophets of the old dispensation I understand that it witnessed generally in a mechanical way. I do not mean by this that the prophets did not

have any joy or comfort out of the witness of the Spirit, -- far from that. But I find they were very much perplexed, and I do not wonder at that. Take the case of Jeremiah, for instance. Now let us remember that under the law covenant, Israel as a nation, or a tribe in the nation, or a family in that tribe, or an individual in a family, whoever put forth his or her best efforts to comply with the requirements of the law covenant, was promised every manner of earthly blessing, and we find it on record in the 28th chapter of Deuteronomy that those prophets were putting forth their best efforts in that way, and therefore they would reasonably expect blessings, but found themselves persecuted and afflicted. They were a type of the Lord's people down in this harvest time. So greatly was Jeremiah perplexed that in the first chapter of his prophecy he brings this matter before the Lord and notice how strongly he comes out, -- a good deal stronger than I would want to come out before the Lord. He said: "Wilt thou be altogether unto me as a liar and as waters that fail?" Surely he was perplexed. Yet I am sure the prophets got a great deal of joy out of the witness to them, and yet I think I understand clearly from the Word that in a general sense it witnessed to them in a general way, and so we read in Peter's first epistle, first chapter, 10th, 11th and 12th verses, as follows: "Of which salvation the prophets have enquired and searched diligently, who prophesied of the grace that should come unto you:

"Searching what, or what manner of time the Spirit of Christ which was in them did signify, when it testified beforehand the sufferings of Christ, and the glory that should follow.

Unto whom it was revealed, that not unto themselves, but unto us they did minister the things, which are not reported unto you by them which have preached the gospel to you with the Holy Ghost sent down from heaven; which things the angels desire to look into."

Then in his 2nd epistle, 21st verse, he brings this thought to my mind rather more clearly and says, "For the prophecy came not in old time by the will of man, but holy men of God spake as they were moved by the Holy Spirit" -- mechanically. While unto the Gospel church, I understand it witnesses more in an explanatory way. I think we will see this is reasonable, because we are living in a time when the light is shining more brightly. I guess we all remember something about what Brother Senor brought to our attention yesterday morning when he told us of the candlesticks, one after another being lighted -- one, two, three, four, five, six, seven. We are down here where they are all shining. And then the Lord tells us in the 30th chapter, the 26th verse, of Isaiah that the light of the moon shall be as the light of the sun, and the light of the sun shall be sevenfold, as though he light of seven days were poured into one. Now we are living in the time when this wonderful light is shining, and therefore we can see readily that the holy Spirit would naturally witness to us more in an explanatory way, and so it would witness through Jesus to this intent. In the 7th chapter of John's Gospel, 17th verse, we read: "If any man will do His will, he shall know of the doctrine, whether it be of God or whether I speak of myself." Then again in the 8th chapter, 31st and 32nd verses, we read: "Then said, Jesus unto those Jews which believed on Him, if ye continue in My word, then are ye My disciples indeed; and ye shall know the truth and the truth shall make you free." Then in the first epistle of Paul to the Thessalonians, 5th chapter, we read: "But of the times and seasons, ye, brethren, have no need that I write unto you. For yourselves know perfectly that the day of the Lord so cometh as a thief in the night. For when they shall say, peace and safety; then sudden destruction cometh upon them as travail upon a woman with child, and they shall not escape. But ye brethren are in darkness, that that day



should overtake you as a thief. Ye are all the children of the light and the children of the day: we are not of the night nor of the darkness." How clear and plain it seems.

Then in Proverbs 4:18, the Lord declares through the writer that the pathway of the just -- the justified -- shall be as a shining light: -- that is, I understand this is true if they use their justification for the purpose for which it was provided. Let the floor represent the fallen condition, let the chair represent justification, and let the platform represent consecration, and consequent sanctification. No one could come up from the floor to the platform at one bound, but he must have a stepping-stone; and justification is provided for that purpose. Therefore if we use it for that purpose, the pathway of the justified will be as the shining light, that shines more and more unto the perfect day. Now, none of us have as yet reached the perfect day on this side the veil, but, thank the Lord, we are closer to it this morning than any others have ever been, -- closer than we have ever been before -- and yet the light is going on and on to the perfect day. The Apostle John gives us some encouragement here: "If we walk in the light as He is in the light, our fellowship is with the Father and with His Son Jesus Christ." And I tell you that will be good company.

But somewhat further would be this thought, in regard to the mechanical witness in the case of the prophet and of the explanatory witness in our case. Let me just cite you to the case of Daniel, and that will be sufficient for this occasion. Daniel had seen many visions concerning the Gentile governments, one in the form of the great image with the head of gold, and the shoulders and breasts of silver, and the lower part of the body of brass, and then iron, and then finally iron and clay mixed. And then he saw great beasts representing the four great universal empires, etc., and he said, I heard but understood not; and he tells us that he prayed to the Lord with tears that he might be permitted to know the meaning of some of the things which he himself had been inspired to write. And for his comfort the Lord said to him, through the heavenly messenger, the angel who acted as the medium of communication between the Lord and Daniel, "Thou art greatly beloved Daniel, but go thou thy way, for the words are closed up and sealed until the time of the end." Then neither wisdom, nor piety, nor education, could open those seals and read understandingly before the time of the end. Indeed it would be pleasant to go on and show how we are in the "Time of the End," and bring forward the Scriptures and chronological proof, but that would be unnecessary with this company, I think.

Now we reach the question, What is the holy Spirit? All beings conscious of life have a spirit. There is no mistake about this. Animals have a spirit, man has a spirit, angels have a spirit, God has a spirit. Now, to illustrate in the case of animals: We sometimes see a man driving a horse along the street, and we notice that it is about all he can do to manage and control that animal, and we say that man is driving a very spirited horse. What do we mean? A horse very full of life, activity and energy. Directly we see another man coming along the street driving a horse; it may be a very nice looking horse, very fat and nicely groomed and all of that, nevertheless we notice the lines are hanging loose, the man with his elbows resting on his knees, and if the day be warm apparently both are half asleep. We say, That man is not driving a very spirited horse. What do we mean? We mean a horse that is not very full of energy and activity, etc. Thus we find animals have a spirit, and we recognize the thought in our common conversation.

Now man has a spirit, and what is it? I answer it is his mind, his disposition, his will. God has a spirit, and here is where the difficulty arises with so many of the Lord's professed people. They fail to distinguish between our Heavenly Father as a spirit being, and at the same time having a spirit. Here they get into a great deal of trouble, and tell us that the holy Spirit is just as much a person as that the Heavenly Father is a person, or that the Heavenly Son is a person – making the mistake of not distinguishing between the Heavenly Father being a spirit being, and of having a spirit.

The Hebrew word rendered spirit in the Old Testament is spelled in our English language "ruach," and Prof. Young gives us sixteen definitions of that word. One of those definitions is spirit, another is mind. And then again there is the word in the New Testament translated from the Greek, spelled in the English "pneuma," and there he gives us three definitions. He defines it as will, understanding, mind. Those are his definitions of the word spirit. Now as I have said, God is a spirit being, and He also has a spirit, His Holy Spirit, and it is expressed in His Holy Word. That is how we come to know what is the Spirit and how it witnesses. God expresses His mind in His written Word, and the more familiar we become with that Word, and by prayer and supplication seek to drink in the mind that was in Christ, the mind of God, the Holy Spirit, the better will we know what the spirit witnesses.

This, then, is an answer to our first question, How does the Spirit witness? It witnesses through the Word. What other medium have we whereby we may know the witness of the Spirit? Let us get familiar with it, dear brothers and sisters. I am glad we are getting more and more familiar with it. I was quite familiar with the reading of the Word before I came to a knowledge of the truth, but when I began to read that wonderful book, the Plan of the Ages, it untangled the snarls, and I did not have to turn very often to the Scriptures to see if those references were given correctly; I knew the Bible read that way, but I did not know how to apply it. How glad I am, as was said last evening in the sermon, that the Lord has not only given us the Lord Jesus, the great Teacher Himself, the principal of the school, but He also raised up suitable teachers at the same time, under-teachers, to help us to know what is the good, and acceptable, and perfect will of the Lord, what His mind is, as expressed in His written Word.

Man is naturally limited in his realm by his five senses, -- hearing, seeing, smelling, tasting and feeling -- and he cannot get outside of that realm as a natural man. Think of it for a moment. These are the senses by which he is environed. Now I do not know but that an angel, or a seraphim, or a cherubim, might have several more senses than men have; I do not know anything about it, but I can see that it might be so, and if he had one or more senses than a man has, he would know a great many more things than a man can know. For instance, I can look right into the eternity before us, and it is not a very difficult matter for my mind to comprehend the thought of the possibility of living and existing on throughout all eternity. But, when I come to turn the wheels of my mind in the opposite direction and think back, back, back into the eternity that lies behind, and then to be informed that back there, there never was a time the Lord God Almighty did not exist, I am lost; I get beyond my depth. Suppose we had one or two senses higher than we do have, for instance as angels may have. No doubt it is just as easy for an angel to comprehend the eternity of the past as it would be for us to comprehend the eternity that lies before.

Well the question might arise right here, are there any human beings that have any more than the five senses? I answer yes, there is a small company during this Gospel Age who have the sixth sense. It is the ability to discern spiritual things. It is not fully developed, because the Apostle Peter tells us that we see (not the world, the world does not see) through a glass darkly, dimly, as though the glass had been smoked or befogged. This is in our spirit-begotten condition, but you remember he tells us by and by that which is in part, the begotten condition, is going to be done away, and that which is perfect, the born condition, will then have come, and then we will see with all the fullness of the divine vision. Will not that be a joy and a delight?

Now in this connection, I cite you to some thoughts suggested by the Apostle in his first letter to the Corinthians, 2nd chapter, 9th to 16th verses, speaking of that 6th sense:

"But as it is written, Eye hath not seen, nor ear heard, neither have entered into heart of man (mind of man) the things which God hath prepared for them that love Him. But God hath revealed them unto us" -- What "us?" Who was he writing to? Turn to the beginning of the epistle and see: The "sanctified in Christ Jesus, called to be saints." "But God hath revealed them unto us by His Spirit." How? Expressed in His written Word, as we have already seen. "For the Spirit (mind) searcheth all things, yea the deep things of God."

Then in the 11th verse the Apostle does some reasoning, calling our particular attention to this thought, he says, "For what man (person -- it will bear that rendering) knoweth the things of a man (or person) save the spirit of man (mind of man) which is in him?" None except those on a higher plane. For instance, you may have a very intelligent horse, or dog, and I have seen some that have surprised me. I call to mind one now, that a few years ago a man owned, and I know that man would say to that dog (and he was a very large one) sitting in the room, not making any motions at all, "Go over to father's and get the morning paper." And if the old father was reading the paper he had to fold it up and give it to the dog, because he would paw him and tear that paper to pieces but what he would get it. Now, how did the dog understand? These are actual facts, and even more wonderful things than that I have seen him do by simply being talked to. Now suppose this man had wanted to talk to somebody about phrenology, or theology, or physiology, or any of the sciences; would he have talked to that dog? He might just as well have gone to the woods and talked to a tree. If he wanted to exchange thoughts with somebody along these scientific lines, who would he talk to? To a man or woman like himself. So the Apostle reasons it out in this connection saying, What person knoweth the things of man, save the spirit of man, or the mind of man, which is in him? Even so the things of God knoweth no man, save him which has the Spirit of God. How plainly the apostle has made that matter. That is why, dear brothers and sisters, you and I have imbibed some of this Holy Spirit, and are able to understand the deep things of God. And still there is more to follow. Praise His Name!

And so the Apostle says, "Now we have received, (that is, the "us" of the other verse, the church) not the spirit of the world, but the Spirit which is of God; that we might know the things that are freely given to us of God. Which things also we speak, not in the words which man's wisdom teaches, but which the holy Spirit teaches, comparing spiritual things with spiritual." Then in the 14th verse, "The natural man receiveth not the things of the Spirit God." And it does not make any difference how good a man he may be, if he is a natural man, if he has not received the 6th sense, he does not understand those things at all.

I have in mind this morning a dear friend of mine, a son-in-law, and outside of the truth I never knew a better man than I know him to be, having proved him from every point, I may say; yet he is a natural man and does not understand these things. I can talk to him about any other subject, and he will listen to all I want to say on this subject, but he makes no reply; he does not understand it. The natural man receiveth not the things that are of God. They are foolishness to him, neither can he know, or understand them. Why? Because they are spiritually discerned. They are discerned by that sixth sense which God has graciously granted to you and to me. "But he that is spiritual judgeth (discerneth) all things, yet he himself is judged (discerned) of no man." How true that is. You and I can explain to members of our own family who love us and whom we love, and if they have not received this spirit they do not understand as Bro. Thomson said, why it is we pursue the course we do. It is a great wonder to them. You may stand shoulder to shoulder with another man or woman, and that man or woman may be a daughter or son of your own father and mother, and yet if you have received the holy Spirit, this sixth sense, they cannot understand you, and yet no blood relationship could be closer by any possible means. Why is this? Well, we understand it is because one is spiritual and the other is natural. And so the Apostle concludes with the 16th verse, as follows: For who hath known the mind (spirit) of the Lord, that he may instruct him? But we have the mind of Christ." We see how these words "mind" and "spirit" are used alternately by Bible writers. They do not confine themselves to either the one or the other; they are just as liable to write mind as spirit, and vice versa, according to expediency.

Now we come to another question, What does the holy spirit witness? I answer different truths to different people at different times. For instance, in the first great dispensation, that was before the flood, it witnessed to Noah for one hundred and twenty years. He was informed that there was coming a flood, and he prepared an ark to the saving of his house, and became an heir of that righteousness which is by faith. Then it witnessed in the Patriarchal Age to Abraham that "In thee and thy seed shall all the families of the earth be blessed." Then in the Gospel Age, it witnessed as to what constitutes that promised seed. If time permits, we will see something about that further on.

Now what were the results of its witness to Jesus? We will take Jesus as an illustration, for He was a perfect illustration and He had the Spirit without measure. I answer that its witness to Him was peace -- peace in time of greatest trial. We have already seen that when the cross stared Him in the face He got the full victory over the mind. That is I understand our Lord had preferences there. If the Father was willing, He would rather have laid down and died on a couch, perhaps, as so many have, because it was death, and not crucifixion, that redeemed us. It was not that He was pleading to be released from death, I would understand, but from the bitterness which accompanied it by crucifixion, with all that it implied. And so He said, if it be possible Father, -- nevertheless, Thy will be done.

Well when He saw it was not part of the Father's purpose, or plan, that He should not drink that cup to its dregs, there He got the full, complete victory and said, Thy will be done. His was a perfect mind, running parallel with the divine mind; there was no crossing of the divine with the human, and it gave Him perfect peace. He said unto the disciples, The flesh is weak, but the mind is willing. Whether He had reference to Himself, to them because they were asleep again

and again when He came to them, we may not fully know, but perhaps He had reference to both. His own flesh was getting weak, and He recognized the weakness in their flesh. He had no doubt they were willing to stay awake with Him, for Peter said, I am willing to die for you, Lord, and the Lord Himself had preferences, but they were in full subjection to the will of God. Thy will be done It was parallel; there was no transverse will. And thus He had peace when He needed it, – very different from the unscriptural witness I told you about earlier in the discourse as my own experience.

"My will, dear Lord, from Thine doth run  
Too oft a different way;  
'Tis hard to say, Thy will be done,"  
In every darkened day!  
My heart longs still to do Thy will  
And all thy word obey.

My will sometimes would gather flowers;  
Thine blights them in my hand;  
Mine reaches for life's sunny hours;  
Thine leads through shadow land;  
And many days go on in ways  
I cannot understand.

Yet more and more this truth doth shine  
From failure and from loss:  
The will that runs transverse from Thine  
Doth thereby make its cross;  
Thine upright will cuts straight and still  
Through pride, and dream, and dross.

But if in parallel to Thine  
My will doth meekly run,  
All things in heaven and earth are mine;  
My will is crossed by none;  
Thou art in me and I in thee:  
Thy will and mine are done.

Let this be our experience, dear brothers and sisters, and then we will have the witness of the Spirit that we are the children of God.

Now the Spirit witnesses through Jesus in the 14th chapter of the Gospel of John, at the 7th verse, -- "Jesus saith unto him, I am the way, the truth and the life: no man cometh unto the Father but by me." Again the Spirit witnesses in another chapter, John 6:44: "No man can come unto me except the Father which sent me draw him." Now a question would arise here in many a thoughtful mind, What particular difference would it make who drew the man or woman to Christ, the Heavenly Father, or the Heavenly Son? Would there be any difference in the drawing? I think not. We do not understand our Savior merely had reference to people calling on

His name and saying, Lord, Lord, or anything of that kind, but to those who would constitute the members of the Body of Christ, and that this Gospel Age is set apart for the purpose of bringing those members to the Body. Just go back with me to the Abrahamic covenant for a moment, "In thy seed shall all the kindreds of the earth be blessed." The Lord does not specify there just what the blessing is to consist of; we have to search the Scriptures elsewhere to find out about that. Peter tells us this restitution was spoken of by the mouth of all the holy prophets, but that is neither here nor there. In thy seed shall all the families of the earth be blessed.

Then we come down to the days of Paul, and the Spirit witnessed to him as to what constitutes this seed. In the third chapter of his epistle to the Galatians, at the 16th verse, we read, "Now to Abraham and to his seed were the promises made. He saith not, and to seeds, as of many; but of one, and to thy seed, which is Christ." Does that mean Jesus only? I thought for a good many years it did. What else could it mean? And today I answer, No, it does not mean Jesus only; it means Jesus, indeed, but it means a good deal more, for at the 29th verse we read, "For as many of you as have been baptized into Christ have put on Christ. And if ye be Christ's, then are ye Abraham's seed, and heirs according to the promise." Then turn to the 12th chapter of 1st Corinthians, 12th verse, and we read from the same pen that just as the body is one -- the human body is one body, but composed of many members, and in that connection he mentions many of them, head, hands, feet, eyes, ears, etc., all the different parts of the one body being members of the one body -- so like that also is the anointed, the Christ. Jesus was anointed to be Head or Lord over the Church, which is His Body, and just as the Head was exalted to the highest throne of heaven at the beginning of this Gospel Age, just so at its close every member of the Body must be exalted to the same nature. There, seated on the highest throne of heaven, it constitutes the promised seed of Abraham, through whom all the families of the earth shall be blessed. And the interval between the first and the second advent of our Lord is designed for bringing these members to the Body, and no man can come to the Son, and be a member of His Body, except the Father draw him.

Now I raise my question again, What difference would it make whether the Heavenly Father or the Heavenly Son drew the members? Suppose, for instance, the Heavenly Father would and is drawing Brother Smith? Would not the Heavenly Son draw the same man? I have not the shadow of a doubt about it; but let us notice that very evidently the Heavenly Father and the Heavenly Son are working along the lines of the strictest propriety, so to speak. That is, one would not even seemingly infringe on the rights and prerogatives of the other, even though they are one in nature. Well, some people say they are one in person because Jesus said, I and my Father are one. But Jesus said also, I and my Father are two. They do not read far enough. He said it to the Jews on one occasion. It is written in the law that the testimony of two men is true. And I am one that earth witness concerning myself, and the Father also beareth witness. Thus He told us plainly that He and the Father were two, so far as persons are concerned, but one would not seemingly infringe on the other's prerogatives. This will explain why the Heavenly Father, and not the Son, draws the members to the Body during the Gospel age, for we must remember that when Jesus died and redeemed our human race from death, He did not redeem anybody to heavenly glory. Why? Because no one had lost any heavenly glory. His testimony is that He came to seek and save that which was lost. Had father Adam ever lost a heavenly inheritance and a spiritual existence, then of course that would have been what Jesus came to seek and to save, but He would not have come in human nature for that purpose. But since Adam lost his human

life and earthly inheritance, that was what Jesus came to seek and to save, and for that reason He did come in human nature. Now when He had accomplished that redemptive work to the entire satisfaction of the Heavenly Father, God raised Him from the dead and exalted Him to glory, honor and immortality on His own throne. Did that give Jesus, strictly speaking, a right to invite Peter, or James, or you, or me, or anybody else, up there to partake of the divine nature? No I think not. But if in the lengths and breadths and heights and depths of the Heavenly Father's wisdom He sees good during this Gospel Age to call one hundred and forty-four thousand and give them specifications concerning development, and if faithful unto death He will exalt them with their glorious Lord and Head, I apprehend He had a perfect right to do that, and Jesus fell in line with the Heavenly Father's plan, and said, I thank thee, O my Heavenly Father, Lord of heaven and earth. Thine they were, and thou hast given them to me to be my companions, my associates; so Father, I will that they whom thou hast given me shall be with me where I am. Thus we can see, I think, why the Heavenly Father, and not the Son, draws the members of the Body of Christ during the Gospel Age, and thus the Spirit witnesses.

The Spirit witnesses again through the Lord Jesus. The Father judgeth no man, but hath committed all judgment unto the Son. Another reasonable question that might occur to any thoughtful mind is, What difference would it make who judged men, the Heavenly Father or the Heavenly Son? Would there be any difference in the decision? No, I think not. Suppose the Heavenly Father should judge me unworthy of everlasting life; would not the Heavenly Son judge me just the same? There is no doubt about it. But again we see these lines of propriety carefully followed out. We remember again, when Jesus died on Calvary and redeemed our human race, He bought the whole human race, living and dead, and that part still unborn on the earth, and the Scriptures declare it was a commercial transaction, even though some people say that against us in a sneering way. I am not afraid to stand up for this truth. It was a commercial transaction. He bought us with His blood, His life, and He took the whole earth as He found it. Now, bear in mind, it was not the Heavenly Son who had sentenced the human race in Adam, but the Father had expressed His judgment six thousand years ago when He sentenced the whole human race to death. That was the full penalty of the broken law. Could the human race get any benefit from a further judgment on the Father's part? I would like to have a theologian arise and explain to me what that benefit could be. Jesus had no personal law of His own to maintain against our race, because it was not Jesus who sentenced them to death, and therefore we can see why it is that the Father judgeth no man, but has committed the matter unto the Son.

But now the question naturally arises in this connection, Is the Son exercising that judgment regarding the world during this Gospel Age? A so-called orthodoxy answers, Yes. I answer, No. I have the Scriptures behind me at this point. He is not exercising that judgment. Take the 47th verse of the 12th chapter of John's gospel, where Jesus said, "If any man hear my words and believe not, I judge him not." Now, is it not strange that if the world is on trial, and the Father judgeth no man, but has committed all judgment unto the son, and the obedient Son refuses to judge? Well, the world is not on trial. He made that matter as clear as sunlight in the last clause of the last verse from which I quoted, when He said, "I came not to judge the world." That was not the object of His first advent. He said, "I came not to judge the world but to save the world." And in those few words He tells us very clearly and definitely what the purpose of His first advent was -- to save the world. Did He accomplish that object? I answer, Yes, He did. "What," says the evangelist and revivalist, "did He save the world? Why, we are fighting as people in the

fire to save soul from eternal torment, and you tell us Jesus saved the world. It is all foolishness." I answer, "Jesus Christ, by the grace of God, tasted death for every man, and God has appointed a day, and that day His Word declares is a thousand years long, in which He will judge the world in righteousness by that man." I would like to bring to your notice some things which the Spirit witnesses concerning that judgment day, but time will not permit, if I say what I want to say in another connection.

So then, we find that while the Heavenly Father draws the members to the Body of Christ, it is the Heavenly Son who is to judge the world, and not the Son only but those who will be His associates in the kingdom, power and glory, for, "Know ye not that the saints shall judge the world"? It is the King, the Head of the Saints, and the Saints shall judge the angels, -- fallen angels, no doubt; other angels we would not suppose need any judging.

"And I, if be lifted up from the earth, will draw all men unto me." Here is another witness of the Spirit through Jesus: -- that is, if I carry out all of the specifications of the Father's plan, so far as the redemptive features are concerned, and be lifted up to glory, honor and immortality, then when this judgment day comes I will draw all men unto me. And so the Lord declares that when that time shall come, He will pour out His Spirit on all flesh, even as during this Gospel Age He is pouring it out on the few, His servants and handmaidens.

I just want to call attention to one more thought in this connection. Notice the Father's willingness to give this holy spirit to those who ask for it. You remember how Jesus put it, -- and I have thought about that so many times, even before I came to a knowledge of the truth. He said, "If a son ask bread of any of you that is a father, will he give him a stone? Or if he ask a fish, will he for a fish give him a serpent? Or if he shall ask an egg, will he offer him a scorpion"? Why, certainly not; you would not want your child's feelings hurt by giving it such horrible insults as that. "If ye, then, being evil, know how to give good gifts unto your children, how much more shall your Father in heaven give the holy Spirit to them that ask Him." (Luke 11:11-13.)

Suppose, in the time of a famine, you have a little child, and you feel very tender toward the child; it cannot talk, it cannot understand, and it does not know why it cannot have something to eat. Then if your little boy, or girl, comes to you with a hungry look in its face and asks for a piece of bread and you cannot give it, and you cannot make the little child understand why you cannot give it, it is a famine and she does not know what a famine is, suppose that by bearing your right arm and having the flesh hewn from it that would satisfy the hunger of your little child: would you be willing? Yes, you would be glad to do it. More willing than that is God to give His holy Spirit, for it was not the bearing of the arm, but it was the giving of the child itself. How glad, how willing, He is to give that holy Spirit! I have come to the conclusion, dear brothers sisters, that if I am lacking that holy Spirit, the fault is my own, and no fault on the Father's part.

Well, then, we feel insufficient for these things. We feel that we lack wisdom, and would like to be more wise. I find myself making so many mistakes, and I am not alone in this respect. I heard Brother Draper say here the other day that he made mistakes every day. Well, I would like to have more wisdom, so as to not make so many mistakes, and the Spirit witnesses through the Apostle James, "If any man (in Christ, I understand) lacks wisdom, let him ask of God who



giveth to all men liberally; and upbraided not." And the promise is that it shall be given to him. Let us, then, seek more and more that wisdom that cometh from above, that is pure, peaceable, gentle, easily to be entreated, full of mercy and good fruits, and the wisdom that will make us wise concerning that which is good, and very simple concerning that which is evil.

Now I want to notice a few thoughts in connection with the last verse of the text, the 17th verse. If we have received that holy Spirit, we are spirit-begotten children of God. Now he says if we are children of God, then we are heirs of God, and if we are heirs of God, we are joint-heirs with Christ, if so be we suffer with Him. Seeing to what extent He suffered, even unto death, to what extent shall we suffer? If unto death, we shall also be glorified together. It will be a wonderful thing, I apprehend, to be glorified with Him. It is a wonderful thing to receive the present truth and rejoice in it as we are rejoicing in it. But, O, what a wonderful thing it will be when the begotten condition, which is in part, is done away and the born condition, that which is perfect, is come, and to be with Him and like Him! You remember the Apostle calls our attention to this thought: "Behold what manner (kind) of love the Father hath bestowed on us (the Church class) that we should be called the sons of God." Or in another place the Apostle Paul expresses it, "Sons and daughters of the Lord Almighty." And I am glad he put it that way, that we should be called the sons of God.

Now just notice that Moses was a faithful servant and one of the grandest characters whose biography is recorded on the pages of history, either sacred or profane. Moses was faithful and God loved him, and stayed by him during all the long period of his service, but I want to impress upon you that he was a servant, not a son, in the Scriptural sense of the Word. Abraham believed God and it was reckoned to him for righteousness, and he was called a friend of God -- but behold what manner of love the Father hath bestowed on us that we should be called the sons of God. Is it not wonderful? It is. "Heirs of God and joint-heirs with Jesus Christ." Beloved now are we the sons of God, by begetting and adoption, and it doth not appear what we shall be, but we know that when He shall appear we shall be like Him, for we shall see Him as He is. Now let me impress the thought that each one who will be a member of the Body or Bride class must be like Him. Do not let this thought get away.

Now, the relationship between Jesus the Head and the Church His Body is brought to our view under a great many different pictures in the Scriptures. It is Jesus the Head, and the Church his Body; it is Jesus the Shepherd, and the Church His Flock; it is Jesus the Vine, and the members of the Church the Branches; it is Jesus, the Chief Corner-stone, the Church the Living Stones built up into Him, etc. But there is another figure I have not called attention to that speaks of the fondest and sweetest ties the human man can revert to -- the relationship between the Bridegroom and the Bride. How shall we illustrate it this morning? I do not know a better way than this; some of you have heard me express it in the same words before but I will repeat it. Let us imagine a great government reigned over by a great monarch, and there is a young crown prince. We will suppose him to be twenty years of age; he is not only princely by birth, education, etc., but in every way his hands are clean and his heart is pure; and the constitution provides that ten years further on when he is thirty years of age he shall take the crown and throne and reign for an appointed time, and for a purpose. Well, just so in the case of our Lord Jesus; separate from sinners, made higher than the heavens, He is able to take the crown and the throne and reign for a thousand years. Now in the case of the young prince the constitution

further provides that when he does take the crown and the throne he must be married; he must have a bride, a consort; and it further specifies she must be like him. Who shall she be? At the court there are usually relatives of the royal family, and always members of the families of the nobility, and so we read about this heavenly court there are cherubim and seraphim, and so on, there, but for certain reasons in the case of the young prince, no member of the royal family or of the family of the nobility, was chosen; and near the king's court and amongst his subjects there is a family, and in that family there is a little girl; she is at this time only ten years of age, but she manifests certain traits of disposition and character that promise a grand harvest further on when womanhood has been reached, provided she is properly trained and developed; and the conclusion is reached that the offer shall be made to this little girl of the privilege of becoming the bride ten years further on, when she would be twenty years of age, providing she complies with all the conditions. The matter is explained to the little girl, as far as her young mind can take it in, and she falls in line with the thought and says, Yes, I will be very glad to put my best efforts forth to learn and develop into all he would have me to be that I may be his bride, his queen. She is placed under the instruction of proper teachers, and the years go by. She is eleven, twelve, thirteen, fourteen, fifteen and sixteen -- now she is getting to be a very large girl, and she knows a great deal more about the young Prince than when her education began, and her desires have only intensified to comply with all the conditions; she is very careful about her practice of music, her study of languages, her embroidery work, and whatever goes to make up the education of a Princess. And she is seventeen, eighteen, nineteen, and now much better acquainted with him and her desires have intensified the more; she has but one year more, and if she passes her examinations that year there will be a great festival occasion -- the marriage of the Crown Prince to the Princess.

Leave her standing there a moment while we go back and see her invitation, as it is expressed in the Old Testament prophecy, in the 45th Psalm, -- I will bring only this one to your notice, for lack of time: -- "Hearken, O daughter." Now she would not be a daughter if not justified. The Lord is not inviting any but the justified. "Hearken, O daughter, consider, and incline thine ear" - - as though He was going to say something that will be worthy of attention. "Forget also thine own people and thy father's house." What does that mean? If we are going to be disciples of the Lord Jesus Christ, are we to ignore the claims of our fathers and mothers, etc? Does not the Bible teach us to honor our father and mother that our days may be long? O, yes. And if we become true disciples of our Lord Jesus Christ in our young years, we will be better sons and daughters than we ever were before; and if we are parents when we become His children, we will be better parents to our natural children than ever before. It is not that, but when Jesus purchased restitution rights and privileges, with life for the whole human race, He purchased them for you and for me, if we are members of that Bride class, just as certainly as He did for the others, and those are the precious things that we can give up, -- "Thine own people, and thy father's house," - - anything that pertains to the Adamic and earthly, no matter how grand it shall appear. "So shall the king greatly desire thy beauty." As the Crown Prince saw the little girl developing, and she was reaching nineteen years of age, would not he naturally desire the consummation? Certainly he would; it would be natural. She was very beautiful when she was ten years old, but was not then suitable to be a queen. Oh, no, she must develop both in an educational way and in other developments. She passes the examinations of that last year successfully, and O, what joy! there is going to be a great festival occasion, the marriage supper of the Lamb.

Leave her here for one moment, clad in all her beauty and glory, while we go back to the closing days of our Lord's ministry. Notice when on the way up to Jerusalem the last time before He suffered He said to the disciples, I am going to Jerusalem, and the Son of Man is going to be delivered into the hands of His enemies; they will scourge and crucify Him, and the third day He will rise again. And they questioned one another on the way, What does he mean? We have been preaching at His dictation for, perhaps two years and more, that the kingdom of heaven is at hand, and now He tells us, while we supposed the kingdom of God should immediately appear, that when He reaches Jerusalem there is going to be, instead of a crown and a throne, a Roman cross and a tomb. What does it mean? They failed to see, as other Jews had failed to see, that God's plan provided for two advents of the one Messiah, and they were looking for restitution blessings at the time of sacrifice and suffering; they were looking for the right thing, but at the wrong time; and when Jesus told them, they did not understand Him. But, ten days afterward when He came amongst them, the doors being shut, He gave them opportunity to do some wonderful studying and questioning among themselves. Why, here He comes and here He goes; these are powers He did not manifest before His death, even though His powers were mighty to the raising of the dead; He did not have these powers. What does it all mean? Why, He is liable to appear to us at any moment, or to depart at any moment; we cannot tell whence He comes nor whither He goeth. No, He had been born of the Spirit, that was the reasons. You remember He said to us, He was going away and would come again and then would establish the kingdom. Can it be that this is His second coming? Will He now establish the kingdom? When He comes to us again in this wonderful manner, let us ask that question, and see what He will say to us. Not long afterwards the Lord came to them in the same way, and this time He led them out to Bethany, and there they asked Him the question, Lord, wilt thou at this time restore the kingdom to Israel? He said, It is not for you to know the times and the seasons that the Father hath put in His own hands. Would they never know? No, Jesus did not tell His disciples that. Some good people in Norfolk will tell you that, perhaps, but Jesus did not say that. "You shall receive power." Power for what? What were they talking about? They wanted to know when the kingdom would be established. You shall receive power to know, to understand, after the holy Spirit is come upon you; it will bring to your remembrance whatsoever I have spoken, and will show you things to come. And when He had made such an explanation as seemed good to Him, all at once He left them and began to start upwards. What wonder and astonishment must have filled the disciples as they gazed on the ascending form of the Son of God, until we are told a cloud received Him out of their sight! Probably it is a bright-shining cloud, a golden-colored cloud, and it was very probably a great company of heavenly beings who had come down to escort Him to the heavenly home, which our Lord Jesus had on high. No son of man could ever describe the joy that must have filled the great Redeemer's heart, as He took His place beside the father on the throne after the absence of more than thirty years, and received the "Well done, my Beloved Son, just as faithful to me in carrying out the work of redemption, with all that implied of suffering and death; as in the great and honorable work of creation in former ages, and now as a reward in part of our faithfulness, sit with me in my throne." And down from that exalted position, He sends a cheering message to the suffering and toiling members of His Bride class during the time of her development, "To him that overcometh will I grant to sit with me in my throne, even as I overcame and am set down with my Father in His throne."

From the time Jesus left them on the hill-top of Bethany until the holy Spirit came to the Church at Pentecost, there was an interval of ten days, as we count time on earth. What may have

occurred in this heavenly court during those ten days we may not know very much about, indeed, but my thought is that one of the grandest festivals that court ever knew up to that time was in evidence on those days. The great triumphant Redeemer had returned successfully the conqueror of death and the grave, and God gave assurance to all men, and promised that He would judge the world in righteousness by Him.

Now at the close of this Gospel Age, the beloved Bride has made herself ready, and there is going to be another festival occasion, as we have seen, -- the marriage supper of the Lamb. "Blessed are they that are called to the marriage supper of the Lamb." She having made herself ready, the question arises (Song of Solomon), "Who is this that cometh up out of the wilderness condition leaning on the arm of her beloved"? And over in the fifth chapter of Ephesians we read, That He might present her to Himself a glorious Church, without spot, or wrinkle, or any such thing, but that He should be perfect and without blemish before Him in love. That, dear friends is the Lord's espoused; she come leaning on the Bridegroom's arm; and the shafts of error and words of malice, will then be unable to do her any harm.

Ascend, beloved, to His joy,  
Thy festal day has come;  
Tonight the Lamb doth feast His own,  
Tonight He with His Bride sits down,  
Tonight He puts on the spousal crown,  
In the great upper room.

Ascend, beloved, to thy Love;  
This is the day of days;  
Tonight the bridal song is sung,  
Tonight ten thousand harps are strung  
In sympathy with heart and tongue,  
Unto the Lamb's high praise.

The festal lamps are lighting now  
In the great marriage hall;  
By angel bands the board is spread,  
By angel hands the sacred bread  
Is on the table laid;  
The King His own doth call.

Long, long deferred, now comes at last  
The Lamb's glad wedding day;  
The guests are gathering at the feast,  
The seats in heavenly order placed,  
The royal throne above the rest --  
How bright the whole array!

Sorrow and sighing are no more;  
The weeping hours are past;  
Tonight the waiting will be done,  
Tonight the wedding robe is on,  
The glory and the joy begun,  
The hour has come at last.

Within the hall is heavenly light;  
Around, above, is love;  
We enter, to go out no more;  
We raise the song unsung before;  
We doff the sackcloth that we wore,  
For all is joy and love.

Ascend, beloved, share His life,  
Our days of death are o'er;  
Mortality has done its worst,  
The fetters of the tomb are burst,  
The last has now become the first,  
Forever, evermore.

Ascend, beloved, to the feast,  
Make haste, the day has come;  
Thrice blessed are they the Lamb doth call  
To share the heavenly festival  
In the new Salem's palace hall,  
Our everlasting home.

At this point Brother Samson sang, and the friends, whose hearts were overflowing with joy, joined with him, the following verses:

And there will be presented the Church,  
His worthy Bride;  
Those faultless virgins chosen,  
His joint heirs to abide;  
They share His royal honors,  
His nature and His throne,  
While written in their foreheads  
His Father's name is shown.

Oh, that will be a marriage  
Such as earth has never known,  
When the Bride and Bridegroom are made one  
Before the great white throne;  
Oh, that will be a marriage  
Such as earth has never known,  
When the Bride and Bridegroom are made one  
Before the great white throne.

And it is to this, dear brothers and sisters, that you and I by the favor of the Lord have been invited. Let us have so high an appreciation of these our privileges that we will renew our vows, and throw aside every weight and whatever acts as a hindrance, and run with patience the race which the Lord has set before us, looking unto Jesus. Amen.

### 3. P.M. -- Discourse

*by Brother A. E. Williamson.*

#### **Subject: "The Bridal Garment."**

The topic which the program announces, and which we will endeavor by the Lord's grace to present to you, is founded on a portion of the 45th Psalm, 9th to 14th verses:

"9 King's daughters were among thy honorable women: upon thy right had did stand the queen in gold of Ophir.

10 Hearken, O daughter, and consider, and incline thine ear; forget also thine own people, and thy father's house;



Brother A. E. Williamson.

11 So shall the king greatly desire thy beauty: for he is thy Lord; and worship thou him.

12 And the daughter of Tyre shall be there with a gift; even the rich among the people shall intreat thy favour.

13 The king's daughter is all glorious within: her clothing is of wrought gold.

14 She shall be brought unto the king in raiment of needlework: the virgins her companions that follow her shall be brought unto thee."

The picture which is here represented is clearly recognized as the picture of a bridal arrangement, and if we had time to do so, we would easily discern from the text that the King who is to be associated with the Queen is Jesus Christ Himself; that God has ordained that there shall be associated with Him in the everlasting glory of

His spiritual kingdom a very special class constituting the Queen of Heaven, which will be the Bride of Christ.

There are various passages of Scripture in the New Testament which refer particularly to the selection of a Bride for Christ and we might multiply these to some extent, but I will call your attention particularly to one which emphasizes who is to constitute the Bride, and this will give us something of a key to the situation. The passage is found in 2 Cor. 11:2. The Apostle Paul addressing a certain part of the Church of Christ which existed at the time he was living uses

these words, "For I am jealous over you with godly jealousy for I have espoused you to one husband, that I may present you as a chaste virgin of Christ.

There are three phases in this text which emphasize the relationship of the church, which was particularly represented in the Corinthians to whom the letter was addressed, which shows to us that relationship was a proposed Bride. The three expressions are, "espoused," "one husband," "chaste virgin." They all signify that this class existed in such a peculiar relationship that if they proved faithful to that condition they would eventually have the blessed portion of being counted as the Queen of Heaven when God would call this Bride to be with Jesus Christ in the kingdom.

Let us notice for a moment some of the conditions existing at the present time, and which did exist at the time David was writing our text in connection with oriental marriages, that we might realize something of the appropriateness of God's inspiring the prophet to use this particular picture with respect to the selection of the Church to be associated with Jesus Christ in His kingdom. In oriental countries the conditions are very different than those which exist today among western people. (1) It was not the individuals themselves who arranged the marriage conditions. They were arranged by the parents of the parties concerned. (2) The individuals were not permitted to see each other when the arrangement was made. It was definitely determined that they should not look upon each others' faces until the day they were actually united, but (3) they were permitted to have a certain amount of communication by way of correspondence, letters passing between the two, and (4) in connection with the wedding, if either of the parties should manifest any unfaithfulness to the espousal which had been made by their parents, they could be treated as though they had actually violated the marriage law, and would be subjected to the restrictions of a divorce as though they had actually been married; and (5) after the wedding for a period of usually about one year if they proved faithful and the conditions were satisfactory, amidst great rejoicing the proposed Bridegroom came to the home of his loved one, received her to himself, escorted her with all the dignity appropriate to his station in life to his own home, and there in a great feast, called a marriage supper, she was inducted into all the privileges of union with her lawful husband.

In this fifth condition we find a remarkable similarity to certain arrangements which God has instituted in gather together a certain class of persons which are to constitute the Bride of Christ and share in His eternal kingdom.

First, it is not the parties themselves which instituted the arrangement; it was the great parent which instituted the espousal condition whereby it was possible for these two to be united. God Himself the Father of all, was the one who originated that there should be any Bridal arrangement at all. It was not Jesus. He did not say, "I propose to take a Bride; I am going to be married. I wish to have associated with me a companion for the administration of my kingdom work." He did not have any authority to say that, and He did not say it. The Church did not say, "We propose to have a husband; we are going to unite ourselves with Christ, and we are preparing ourselves for relationship with the Lord in the kingdom, and we will call that the relationship of Bride and Bridegroom." She did not have any authority to take any such a position. God was the only one who was in a position to make such an arrangement, and it was God who has ordained that there shall be this condition. God Almighty has proposed that there shall be a marriage and that His Son, our glorious Redeemer should be the Bridegroom, and that

there shall be gathered together a special class of persons whom He can look upon as His daughter, if that class fulfills the conditions He shall lay down.

Secondly, these two are not permitted to look upon each others' faces until the great marriage day. The Bride recognizes the existence of her future Bridegroom by the eyes of faith, and in no other way. She is called upon to endure a special testing and to realize that under the Lord's arrangement she is learning certain special lessons in connection with it.

Thirdly, there is a condition which the Lord has arranged so that she shall have made up to her for the loss in the second condition, namely that God has provided for her certain correspondence -- precious letters, love letters, if you please, which God has arranged, to be put into such form that they can be perused by the one who is being made ready for the queenly position, and here we have them particularly in the New Testament part of the Bible. They are the messages which Jesus Christ has arranged shall be communicated to His future Bride, and which shall give her the refreshment, and stimulation, and comfort, to prepare her while she is on her way to the heavenly city.

Fourthly, just as in the oriental arrangement there was a possibility of a serious estrangement and separation, so in this special arrangement which God ordained. If those who have entered the race to become members of His Bride should lose their faith and confidence, and if they should turn their thoughts and affections on some other one, if objects of an earthly kind would attract them instead of the one to whom they had been espoused in their consecration, then the Lord would see to it that they should be divorced from relationship with the Bride of Christ, and they would not be permitted to share in the same favor of the Lord, but some others would be brought in to take their places in the blessed arrangement God had made. But if they proved faithful, trusting in the Lord's grace, and recognizing the comfort and assurance that He has provided that they should make their calling and election sure, Jesus Christ shall fulfill the precious word of promise as recorded in the 14th chapter of John's Gospel, the first three verses, where He says:

"Let not your heart be troubled: ye believe in God, believe also in Me.

2 In my Father's house are many mansions: if it were not so, I would have told you. I go to prepare a place for you.

3 And if I go and prepare a place for you, I will come again, and receive you unto myself; that where I am, here ye may be also."

And when God's good time has fully come, and the Lord has reached the place which God has ordained for the establishment of His glorious kingdom, He shall take unto Himself His great power and begin His reign over all the earth, and He shall receive unto Himself these faithful, waiting ones who sought to fulfill the obligations of an espoused bride, and usher them into the glories of His wonderful kingdom, and He shall permit them to sit down in His throne and reign with Him over all the conditions which the Father has arranged shall minister blessing and comfort and grace to all the families of the earth.



Now, dear friends, this is the thought which we are to have in mind with respect to the great work which the Lord is carrying out at the present time -- the great work which God has wedged in, so to speak, between that accomplished by Jesus Christ when He gave Himself a sacrifice for the sins of the whole world, and that when Jesus Christ shall pour out the blessings upon the whole world, by reason of His sacrifice. Until this Bride shall have been found, that particular feature of co-operation which the Lord intended should be accomplished in connection with the administering of the precious benefits of the sacrifice of Jesus Christ, will not have arrived. But when the Bride shall have been gathered together, then the Bridegroom and Bride, united in the glorious authority and spiritual power which the kingdom represents, shall direct the government, which shall be all powerful for the benefit and help of every member of the human race who wishes to profit by it.

Now the question arises, where could God get such a glorious company as would necessarily occupy the position described in such language as we have been referring to from the word of the Lord? Where in all the earth would it be possible for God to pick out such a class of individuals who could live up to such conditions as would be appropriate for so glorious an estate as the kingdom of heaven? The Scriptures emphatically declare with respect to the condition of every individual of the human race that they were born in sin and shapen in iniquity, that there is none righteous, no, not one, that from the crown of the head to the sole of the feet there is no soundness at all in them. Evidently, then, there is not one that is fit to be in such a glorious position according to his natural birth, but it is essential that they must be in some kind of an acceptable condition or they never could be approved in God's sight, or acknowledged as worthy of a share in such a favor as would be represented in brideship. This thought is emphasized in the first part of the text which we have called to your attention in the 10th verse, "Hearken, O daughter." The world in general has no relationship to God as a daughter; they are not in any degree reconciled to Him and in favor in His sight, because by reason of their wicked works they are properly described as enemies, separated from God and under a terrible condemnation.

The Apostle Paul in Romans 5, tells us with respect to the general situation of the whole world, "By one man sin entered into the world and earth by sin, and so death passed upon all men, in that all have sinned." And then the declaration of the Word is that God looks not upon sinners. Taking these two texts together, it would seem an impossibility for God to call any of the human race to be members of a class called His daughter. And then are any going to be members of a class that could be invited to be associates in so glorious a privilege as the Bride of Christ? We answer that they must take a position that the Apostle emphasizes in the 3rd chapter of Galatians, 26th verse, and when they have fulfilled that condition then they have come into the relationship in which it would be appropriate to use the precious, endearing expression, which this 10th verse of the 45th Psalm uses. Galatians 3:26 says: "For ye are all the children of God by faith in Christ Jesus." That is the relationship and that is all that is necessary to be done in order that the relationship may be established -- to exercise faith in Jesus Christ constitutes the individual a child of God, and having exercised that faith, then this exhortation is appropriate, whereas it previously was not. The one who has exercised this faith hears this blessed exhortation, "Hearken, O daughter." The one in the faith is now able to appreciate the invitation, because that one has come nigh unto God through the precious blood of Christ.

The Scriptures suggest to us a very beautiful symbolic thought in connection with the situation; the thought is that God has made a gift to the individual, and that gift is the robe of the righteousness of Christ; the individual is represented as being covered from head to foot with such a covering as would conceal from the sight of God the imperfections of the individual, so that when God thus inspects the person who is presented before Him as a daughter, He would realize that the righteousness of Jesus Christ separated all the imperfections from His sight, and the individual is perfect before Him. And this is what the Scriptures emphasize as the doctrine of justification by faith. Paul puts it in the first verse of the 5th chapter of Romans this way: "Therefore being justified by faith, we have peace with God, through our Lord Jesus Christ." Faith brings a condition of reckoned perfection in the sight of God, even though actually the individual is still depraved, and in his imperfect condition, because he has not been thoroughly renovated so as to take him back to the state Adam was in before he committed sin. It is not a righteousness of his own, but God looks on the condition which is reckoned to the individual rather than upon the actual condition of the individual himself. He is a child of God by faith in Jesus Christ, covered with the robe of righteousness of our dear Redeemer. And when He has come into that condition, then the exhortation is brought to the person's attention, "Hearken, O daughter, and consider" -- carefully attend to that which I am about to tell you of a glorious privilege and a wonderful opportunity which you never previously enjoyed. "Forget also thine own people and thy father's house." Whatever this means, dear friends, we wish it to be especially and emphatically considered that it is not something the individual is called upon to fulfill while he is a sinner. The individual is here called a member of the daughter class, and that individual must have partaken of the benefits of the righteousness of Christ, and become a child of God by faith in Jesus Christ, before he could hear this exhortation and acceptably fulfill it. God hears not sinners, and those who are in a sinful condition must in the very first instance recognize the redemption of Jesus Christ through His precious blood. When the individual has done that he realizes he is now called to take some special relationship with regard to his position before God. The thing which he is called upon to do is to forget something, let something go, to step aside from something previously enjoyed, and to take hold upon something else -- "Forget thine own people, and thy father's house." "Thine own people" are the people who pertain to the human race. "Thy father's house" is Adam's house, because Adam is the father of the whole human race. Adam's house is the house of the human nature; the house which God created perfect in the garden of Eden, in which Adam was permitted to live as long as he proved obedient to God's will, and in which he continued to exist in a measure of perfection, but gradually lost his hold upon it until the day that he died; and he communicated in its imperfect state the same human house to every member of the human race by the process of degeneration; and today the members of the human race experience whatever blessings they enjoy while they are in the house, the earthly tabernacle of clay which belongs to the human condition.

The prophet here exhorts the individual who has become a member of the "daughter" class to forget his human nature, to lay aside the interest he has upon the affairs that pertain to this present life, and to take hold on something else.

In order that we might as clearly as possible understand this matter, let me use an illustration: Let us imagine a dairy maid in her father's dwelling place, and associated with the affairs that pertain to farm life, the milking of the cows, the pasturing of them, etc., the milk pans, the milk and cream, and all the various interests that would be associated with that condition in life. Suppose

this young woman should one day come into contact with the prince of the realm, and this prince, charmed with some beauties which he noticed in her, considered that it would be proper for him to invite her to become his wife, and he should lay before her what advantages and attractions would be hers by becoming a princess, united with him in marriage, when they should be ushered into the authority of the kingdom, administering its various affairs to their own honor and the blessing of the people. The invitation to the woman to forsake the interests pertaining to her dairy-maid's condition, and to look forward to the position of queenship in the government of the kingdom, would be an invitation to forsake her father's house, to let go that interest in order that she might take hold of an interest which was far superior, something that would give to her a great deal of authority and responsibility, and bring blessings to many persons if she would use the opportunities aright.

The individual would not be invited to let go of something that was bad in order to take hold upon something that was good, and I would like to impress that point in connection with the invitation that comes to the class of persons who are called upon, if they appreciate the opportunity, to become members of Christ's Bride. The Lord does not ask them to leave a bad thing in order that they might lay hold on a good thing. The Lord asks them to leave a good thing in order that they might take hold upon the best thing. And, dear friends, it is a far more trying position, and a far more searching test of one's willingness to be obedient to the Lord, to forget something desirable and attractive of itself, and lay hold upon something that bears simply the relationship of higher attractiveness, than to let go of something that is miserable, and insignificant, and unrighteous of itself, in order to take hold upon something that is pure, and good and true. And everyone of us, as the Lord's people, who has appreciated the invitation of this present time to do the Lord's will, realize that the test comes from this standpoint -- to let go the interests that pertain to the dairy-maid's condition would not be saying, Why, this is not good; this is evil; there is wrong associated with that, and I do not want to be in a bad position, and therefore I will drop this and take the good position. It was not that; it was to invite the young woman to let go the ties which bound her by the laws of heredity and blood, and all the general associations of her life, and wrenching her heart strings, perhaps, in the operation, in order that she might form new ties, and different attachments, and engage in a work that would require her to perform a service in the world that would be noted by everybody, and to give her first attention to the Lord's service, if she appreciated it; and that is exactly the relationship brought to us, -- to let go the ties, interests, and affections which attach to the earth, and to form an entirely new set of ties and interests, attaching them to heaven; a condition which we have no association with naturally, and which we have to learn by studying carefully the various instructions which he letters the Lord proposed to send to His Bride-elect properly contained.

When the individual has heard this exhortation to forget one's own people and his father's house, that individual has heard in different language the word of Romans 12:1, "I beseech you therefore brethren, by the mercies of God, that ye present your bodies a living sacrifice, holy, acceptable unto God which is your reasonable service." And, dear friends, there is a great deal in that passage of Scripture which a great number of persons thoroughly neglect and overlook. The Apostle is not exhorting that the individual should forget some things that are bad and unrighteous, that he should sacrifice some things that are evil, and not in harmony with morality, and that he should try to do things that are right and good because the things that are evil should be set aside and the things that are good should be taken hold of -- that is not the standpoint the

Apostle is representing at all. The Apostle is presenting the exhortation to a class of persons who have already left the things that are bad, and unrighteous, and out of harmony with the Lord's will. I have heard some persons take this very exhortation of Romans 12:1, who have experienced simply the elementary blessing of justification by faith, and in their testimony with respect to the Lord's grace they have put the matter in this shape: "I thank God I have put all upon the altar; I have laid my pipe, my tobacco, my theater-going, my card-playing, my evil associations, all on the altar; I have given everyone of them to the Lord." My dear friends, they never did anything of the kind. God would not accept an offering of that sort. God would not allow such a despicable presentation to be offered to Him upon the holy altar upon which He has ordained may be offered sacrifices acceptable before Him. When God wished to represent in a picture what was acceptable in His sight, he gave most elaborate instructions in the Books of Leviticus and Deuteronomy regarding the sacrificial arrangements of a perfect character, and everyone of those sacrifices were required to be without blemish. If God required the typical offerings to be without blemish, would He in any less degree require that these things which were antitypically offered would be without blemish? It is essential that Romans 12:1 shall be understood as exhorting to a perfect offering, and that is exactly what the Word says. "I beseech you, therefore, brethren" -- and the word brethren indicates a class of persons who have come into relation by cleansing in God's sight, so they are free from their condemnation -- "by the mercies of God, that you present your bodies a living sacrifice, holy" -- and if the offering is not holy by reason of its having been cleansed from its filth, sinful condition, through the application of the precious blood, of course it is not fulfilling the last clause of the verse which says, "acceptable unto God, your reasonable service." The individual who has been merely justified, and who thinks he is presenting his evil companions and bad habits to the Lord as an offering, is simply leaving them with the world from where he took them, so that he might have himself completely separated from those wrong associations, in order to set himself before God as an acceptable offering, when he would present his body, not his bad habits, not his associations, but his body cleansed from unrighteousness by reason of his exercise of faith in Jesus Christ, to the Lord, in order that he might do the Lord's will to the best of his ability. The making of his body a living sacrifice, signifies that it would be first the sacrifice of his whole life, not a little bit of his life; every day of his life is to be continually given to the Lord, to honor the Lord in all of his interests in order that the Lord might be pleased with him, and prepare him for whatever He has for him in His kingdom.

When an individual has accepted such an invitation as this he is permitted to realize that there is something further in connection with the sacrifice he is called upon to make. "Forget thine own people and thy father's house," reminds us of the great privilege, which Jesus Christ, by the grace of God, purchased for the whole human race, when He died on the cross at Calvary. Adam in the garden of Eden had a perfect human house. He lost it by reason of his sin. Jesus Christ purchased it by reason of His faithfulness even unto death, which was consummated at Calvary. And when Jesus establishes His glorious kingdom on the earth, and institutes righteousness, the purpose of that kingdom is that the whole world of mankind will come under His dominion, and will then have the blessed privilege of coming into harmony with God's will, so that each one of them may be restored gradually during the thousand years of Christ's personal reign, back to the grand and perfect condition Adam had before he sinned. In other words, when that glorious time shall come, the individual who did not have a proper chance for salvation in his previous experience, shall have the glorious opportunity of being restored to Adam's house, in all its grand perfection,

through the grace of Christ, their glorious Lord and Redeemer. And that great blessing is one to which you and I naturally are entitled; and if we went on in ignorance of the Lord's will at the present time, and were favored of the Lord during that glorious period, we would have the opportunity of taking hold upon those blessings, and seeking to fulfill the Lord's will, in order to get back to the perfection of Adam's house. But the Lord graciously invites us to forget that house, to let go our claims on the privileges of restoration to what Adam originally enjoyed, laying that all aside so that, by the Lord's grace, we would be able to take hold upon another house, a house which is entirely different from that with which Adam was associated; and a house in order to get which we must entirely separate ourselves from all claims to the house which we now occupy.

Just as the dairy-maid in her humble home occupied by her father, and perhaps by his ancestors for many preceding generations, would separate herself from all hope of remaining in that condition when her bridegroom came to receive her to himself, and should look forward to the hope of an entirely different kind of a house, and an opportunity of administering kingly government with her king and husband when the due time would come, so by the Lord's grace we are called to let go of our associations with the earthly conditions, and to lay hold on the associations of the heavenly conditions to which the Lord invites us; this being the thought which evidently the Apostle is impressing in the fifth chapter of his second letter to the Corinthians, where he says, "For we know that if our earthly house of this tabernacle (that is, Adam's house, the house that we made a consecration to sacrifice and give up) were dissolved, we have a building of God, a house not made with hands, eternal in the heavens." It is a spiritual house. It is a house that belongs to the very highest order of nature which God could provide, and it is a house which is absolutely reserved for that class of persons who shall make their calling and election sure to membership in the eternal kingdom of Christ.

Now, dear friends, noting the suggestions which are brought to our attention in the picture, the prophet here uses, notice that he says in the 13th verse: "The king's daughter is all glorious, is all glorious within, her clothing is of wrought gold." Verse 14, "She shall be brought unto the king in raiment of needle work." I would like to emphasize the revised portion of this particular part of the passage. The revised version represents the matter much more accurately, and gives us the picture of the queen just as she has entered the queenly condition: "The king's daughter within the palace is all glorious." Not while she is here on earth, not while she is still in her humble attitude, surrounded by the imperfect conditions with which she was associated naturally, not while she is making herself ready to share in the glories of the kingdom, but after she has fulfilled the conditions, and after the Bridegroom has arrived and taken her to be with himself, then the king's daughter within the palace is all glorious.

"Her clothing is of INWROUGHT gold." Mark the difference there between the revised and authorized versions, the authorized version saying that her clothing is of wrought gold, as though it were endeavoring to suggest that the clothing is a robe of one great piece of gold hung from the neck to the heels, and that this cumbersome, inartistic adornment would make her specially attractive in the sight of God in the kingdom, which is untrue; it would be entirely inartistic and unattractive; but as the prophet is presenting it, her clothing is of inwrought gold, which would suggest something that is worked in, as of some kind of ornamentation, in order to make her particularly beautiful and attractive when she would enter into the presence of the king, clothed

in the precious wedding robe that God wants her to adorn herself with, in order that she might be meet for the inheritance of the Bride of Christ.

"Her clothing is of inwrought gold. She shall be brought to the king in raiment of needle work." Put these two together, inwrought gold and embroidery work, and we get the relationship which we believe the Lord inspired the prophet to present to us, -- the picture of the queen having undertaken to prepare herself for queenly association with the King in the kingdom, and receiving instructions in relation thereto from the precious love-letters of the New Testament, this queen, laboriously taking the robe of the righteousness of Christ and working into it certain golden threads of embroidery, which would make that garment rich in ornamentation, and then when she had finished the work of embroidery, transplanted from her earthly condition into the glories of the kingdom of heaven, with a robe perfectly fit for association with the king, and very properly described by the prophet when he says, "She is all glorious within the palace." The embroidery which the Lord provided was that she might realize what was necessary to do in order to make her garment beautiful, inwrought into the very fibre of the garment, and thus a wedding robe provided which would be appropriate for her queenly state.

Dear friends, the obligation upon the elect Bride of Christ is that she should help make her own garment beautiful and attractive before her king, and not until she shall have done this will she be received with joy and thanksgiving and acknowledgement of her faithfulness in the presence of the Glorious One with whom she shall rule over all the earth in due time.

These letters which the King has given to the elect bride, instruct her that she must put in all her time and attention upon this particular work of putting the golden embroidery in its proper position, and weave it into the places that He has designated, so that a beautiful ornamentation shall eventually be worked out, and she is to consider that her obligation to her Lord is so important that no other work can be done while she is endeavoring to prepare that garment for a share in the kingdom. And when we have considered just what is represented in the development of the ornamentation upon the garment to make it a wedding-robe, I think you and I will agree that a woman could never be able to do another thing but ornament that one robe for that glorious occasion, and that if she left that work to attempt to do something else she would lose such valuable time that the work would likely never be finished.

But just one moment to emphasize the relationship between the two doctrines of faith and works, the two doctrines which have been frequently set up by different classes of Christian people as supposedly antagonistic; one class emphasizing the assertion that only faith is essential to eternal salvation, and that if one manifested the required faith at the last moment of one's existence, the next instance he would be swept into glory to inherit the kingdom of heaven; and on the other hand another class of persons emphasizing the thought that if one develops the right kind of work, it does not make very much difference whether they have believed in Christ, whether they have recognized the precious blood of our glorious Savior or not, the fact that they did what they thought was right merited for them God's eternal blessing, and they likewise at the end of their meritorious career would be permitted to go into the kingdom and receive all of its favors.

Now the Scriptures do not represent either of these doctrines from this standpoint. The Scriptures emphatically declare that without faith it is impossible to please God. They likewise limit the

matter still further, so that not only general faith in God is required, but likewise faith in Jesus Christ, His glorious Son our Lord. In the text we quoted a while ago, it says, "Ye are all children of God by faith in Christ Jesus." And thus the very foundation of the Christian religion is laid in recognizing that faith in our Redeemer must be manifested, and in no other way can the basis for our acceptance in God's sight be obtained.

The robe is the evidence of that fact. It cannot be purchased. All the good works in the whole world would never purchase that glorious robe, or make the individual fit to stand in the presence of God. He must have the gift of God through Jesus Christ our Lord by exercising that one simple element of faith in our dear Redeemer.

And then when the faith has been manifested, God ordained that the individual, in order to get a place in the kingdom, in order to share with Jesus Christ in the glories of the queenly position on the throne, must develop certain works, without which it would never be possible for the person to have faithfully fulfilled the obligations and be ready for association with our Lord in the future.

We are not saying that individuals who have not been particularly doing work in the present time will never get any blessings. In his address a week ago, Brother Russell emphatically presented the matter from the standpoint of the Scriptures that thousands and millions who have never had any knowledge of Jesus Christ, and never had an opportunity to do anything in the Lord's service will be blessed when the Millennial kingdom of Christ is established. What we are emphasizing is, that no person shall ever inherit the kingdom of heaven, no person shall ever share the glorious position of a member of the Bride of Christ who has not fulfilled the Apostle's exhortation in his letter to the Philippians, where he says, "Work out your own salvation with fear and trembling, for it is God that worketh in you both to will and to do His good pleasure."

And so we have the basis in the garment representing our faith. And then upon that working in the precious golden threads of our consecration representing character development, the Queen is being made ready for her association with her Lord in glory. Now, dear friends, we want to find out exactly just what it is the Lord expects us to do, which would correspond to this putting into our garment of the golden threads that would properly constitute an ornamentation, fit for a wedding-robe, and the Apostle Peter tells us just what are the conditions in his second epistle, first chapter, beginning with the 5th verse. In the 4th verse the Apostle tells us something which suggests this very thought of golden threads. He says, "Whereby are given unto us exceeding great and precious promises that by these we might be partakers of the divine nature." Now all of us who have had the privilege of studying matters together for some little time, notice the symbolic significance of gold; that in the scriptures it signifies the nature of God, and that in the various symbolic institutions of the Old Testament where gold is used, it represents to us the character of divinity. The Apostle is here telling us God has given to us as His people who are called to be members of the Bride of Christ, the great privilege of being made partakers of the gold nature, the divine nature, the very highest nature, -- as gold is the very highest of the metals.

When the Apostle has emphasized that thought, then he brings to our attention the necessity of bringing in certain characteristics in harmony with this nature, and the relationship is very clear. If God has ordained that we shall attain in due time to the possession of the divine nature, it is

essential that we shall understand in the present time of what that nature consists, as far as its moral qualities are concerned. It is not possible, dear friends, for us to be ushered into the kingdom of heaven without any preparation. It is not possible for us, fixing our thoughts, and purpose, and attention, upon the earth all the days of our life, to expect that at the last moment the Lord will so change our characteristics, and our old way of looking at things, that when we shall be ushered into the kingdom of heaven, we would find ourselves in complete harmony and accord with that glorious situation. It would be absolutely impossible to expect that that could be fulfilled, if the kingdom is a spiritual kingdom, and if it consists of such glorious arrangements that the Apostle Paul could say, "Eye hath that not seen, nor ear heard, neither have entered into the heart of man, the things which God hath prepared for them that love Him." It would be impossible for any individual to enjoy this condition unless he had learned something about the situation before he would be translated there. It is essential that those who expect to be of the divine nature should have the characteristics that will enable them to appreciate the divine nature; they must get these characteristics into their minds and hearts. That represents the ornamentation of the wedding-robe, to make it fit for the kingdom. And then the Apostle gives us the outline of the character, so that we might be able to appreciate the obligation upon us. In the fifth verse he says, "And besides this, give all diligence" -- here is the necessity of setting all our time upon the inworking of the golden threads; if we are not doing that we are neglecting the precious time necessary to make us ready for the bridal state. Giving all diligence means to be neglecting some of the very things people consider the most important in this world, because they imagine the present is the only time the human race will have opportunity for eternal salvation. The usual suggestion is that as soon as you are justified by faith in Christ, you should go out and make somebody else a Christian. Now, dear friends, it is an obligation upon every Christian to so let his light shine before men that they, seeing his good works, may glorify the Father which is in heaven; but the individual lets his light shine by his own character development, and by the manifestation of his own endeavor to produce the characteristics that are in harmony with the great nature which he expects to attain in the kingdom; and what he is obligated to do is not to go out and preach to the whole world the blessed tidings, because he cannot reach the whole world at the present time, but to make himself ready for the grandeur of the kingdom, which, when it is established, will so effectually preach to every member of the human race that not one will be deprived of the glorious opportunity of eternal salvation. It is to get ready to do something in preaching the Gospel that the Bride Class is expected to be giving all diligence in putting in the precious golden threads which will constitute that ornamentation to make this garment a wedding robe in harmony with God's instructions.

Giving all diligence, "Add to your faith, virtue." Now in these two words, faith and virtue, the Apostle mentions the first two qualities of Christian character which must enter into the robe. But notice for a moment the word "add." This is an unfortunate translation; it does not signify in the original Greek to merely add one quality on top of another, as though the Apostle were to say, put in all of the first quality I mentioned, and then after you have gotten that all in, put in all of the next quality, and after this is all in put in all of the next quality, and so on, because, dear friends, that is contrary to the facts. Having faith, we do not develop one quality at a time, getting all of virtue properly in our character, and then produce the next one in its logical order. We develop a little bit at a time, and that is exactly the thought that is intended to be conveyed by the word "add." The original is properly translated "superadd," and that means to add a little more from time to time, according as the necessity comes in bringing together the various qualities that



are to be worked in as a glorious ornamentation. The first quality is put into its place for a little space; a little bit of the drawing in of the golden thread is manifested, and we strive to develop along that line; and we find we cannot get very far until we have to work in another quality, because the peculiarity of the arrangement or the ornamentation requires that another one shall come in just a little bit after the first one has been worked; and then when the second one is worked a little ways, we find we cannot get very far until we must have another one in the garment if we are to make the ornamentation right; and so we bring in the next quality, and after we have gone a little ways with that, we find that we have to put in a little more of the first, then bring in some of the fourth, then a little more of the second, then a little more of the first, then bring in a little bit of the fifth, and then some of the first again. And so going on from one to the other, and superadding to each one, until as the arrangement progresses we find we are superadding little by little and intertwining these various qualities represented in the ornamentation, until the last quality crowns them all. And thus the glorious robe approaches the completion which the Lord ordained, and we are ready for a grand entrance into the glorious kingdom. We are spreading a little at a time to every one of the qualities, according as the Lord wants us to do.

Now the Apostle says, "Superadd to your faith, virtue." The first quality you must have is virtue. Faith is the very first foundation. It is, so to speak, the thread that runs all around the bottom of the garment, and from which all the others must proceed. It is not merely the faith which brought justification, but we must have the faith that presides in all the experiences of our Christian life, or we shall never be able to complete the work the Lord gave us to do. Some persons think all that is necessary to do is to manifest faith in Jesus Christ, and get justification, and then everything else depends on the work. Dear friends, you try that for a little while, and forsake the faith with which you began, and you will never be able to make any progress in the Lord's way at all. You must have faith all the way along. So faith is not merely represented in the precious robe which was the gift of the Lord because of our faith, but faith is represented in the precious golden thread which constitutes the very foundation of the ornamentation; we have to put it in as a characteristic of our new nature to make us ready as members of the Bride class for the precious privileges of the kingdom of heaven. We began with faith, and we get a little bit of faith in its proper position, and then the Apostle says to superadd to your faith, virtue.

The word virtue is not a good translation, either, dear friends. The ordinary conception of that word is purity, innocence. That is not the thought the Apostle is suggesting. The innocence is represented in the cleansing, in the garment. The Apostle is presenting to us a characteristic of Christian development. Superadd to your faith fortitude, which is the proper rendering of the original Greek; or, if we want to express it in just as clear and literal language as we can, -- manliness, courageousness, standing up for the truth in the midst of a wicked and perverse generation, which would endeavor to overthrow our faith and prevent us from fulfilling God's glorious law in connection with our character preparation for the kingdom.

We began with a little faith; we manifested that faith by realizing what the truth was, taking hold of it, and making it ours by the full consecrating of ourselves to the Lord; and then we showed by some of the experiences of our daily lives that we had sufficient faith to trust in the Lord that He would guide, and direct, and comfort us, and then we began to proclaim the truth to others. What was the result? Why, people began to antagonize us, and try to overthrow our faith and to tell us

that we had gotten the whole thing mixed up, that our faith was a great mistake. What did we do? Did we say, "Oh, I think I had better let that all go, Mr. So and So says it is not true after all, and I will drop the thing?" No, we did not say that. We exercised fortitude; that is, we stood up for the truth. We realized that it was our duty now to be manly, not to be squeamish, not to have a cowardly spirit, but to say, By the grace of God we were going to stand, being strengthened with the fortitude that comes from the knowledge that this precious truth we have been studying is God's own glorious plan. So we endeavored to proclaim the message as the Lord gave it to us.

But we did not get very far in bringing the golden thread of fortitude into this wedding-robe until we found we had to have another quality made manifest. The Apostle says, "Superadd to your fortitude, knowledge." We knew a little about the Plan of God at the beginning, but in our earnestness and zeal we went forward manifesting fortitude in defending the truth, and found various arguments presented that needed to be answered from certain standpoints in the Scriptures which we did not know anything about, and that sent us back to the Bible, and we started to study to show ourselves approved unto God, workmen that needeth not be ashamed, rightly dividing the word of truth. We developed the quality of knowledge, and got more and more information with respect to the glorious message of divine grace. Then when we were doing that we were bringing in the third quality, the golden thread which is so manifest in the ornamentation in the precious garment in order to make it a wedding robe fit for the kingdom of heaven.

We did not get very far in the development of the knowledge of God's glorious truth until we found there was another quality to be brought in. We realized we had developed faith for a short while, after that we had produced a manifestation of fortitude for a little time, and that we had come forward to some extent in the knowledge of God's glorious plan, and that all of these various things were requiring the demonstration of another quality, which is absolutely essential to the carrying out of the remainder that was laid on us as a responsibility, and so the Apostle said, "Superadd to your knowledge, temperance." This is an unfortunate translation also. We do not understand that the Apostle is describing merely a certain amount of moderation governing our thought and appetites with regard to eating and drinking, but that he wants to emphasize something that will control in every act of our daily lives; and so the Apostle's thought in this word is self-control. Dear friends, in this expression the Apostle is presenting one of the chief obligations that belong to us as new creatures, because we are still in the flesh.

To use again the picture of the dairy-maid class, -- we are still surrounded by our father's conditions, we still have the pails and pans and other things to look after that are incidental to our present existence, until the Prince shall come and receive us to Himself; but are we going to set our affections and thoughts and purposes upon these things, and to think that we might as well let our minds dwell on them, that maybe the Prince will never come, that maybe we will never have the opportunity of being associated with Him as His Bride? Are we going to do that? Dear friends, if we are doing that, then the quality of self-control is not being exercised. If our minds run off in a side direction, and we allow our affections to center on some individual who belongs to the earthly race, if we are thinking about the things that pertain to the earth from such a standpoint, when we made a covenant with the Lord that we would be thinking about Him, and would be preparing for His kingdom and association, and with the administration of His glorious spiritual arrangements, then we are losing self-control. We are not getting one of these precious

golden threads in its proper relationship in the garment that we are to make ready as a wedding-robe. But, on the other hand, if we are faithful to the exhortation of the Apostle in the 3rd chapter of Colossians, the first three verses -- "If ye then be risen with Christ, seek those things which are above, where Christ sitteth on the right-hand of God. Set your affections on things above, not on things on the earth, for ye are dead and your life is hid with Christ in God" -- we are bringing in another golden thread; we are putting it into its proper relationship in the garment the Lord gave us to embroider; we are making ourselves ready as the bride of Christ for a precious share in His kingdom.

It is exceedingly important that we hold to the position suggested by the Apostle when he was writing his first letter to the Corinthians: "I keep under my body, and bring it into subjection; lest that by any means, when I have preached to others, I myself should be a castaway" (1 Cor. 9:27). We are still in the body; we are still associated with the old conditions; we are still connected with the father's house; we have not left it; we must be here in this earthly tabernacle until the Lord changes us and puts us into relationship with the glorious, eternal, permanent house of the kingdom; and we are to keep these bodies in subjection; we are to hold them under control, and when we are holding them under control, we are getting this particular quality which the Lord is so emphatically presenting to us through the Apostle in this expression.

Then we do not get very far in self-control, until we find there is another exceedingly essential quality. We have learned something of faith, and we have learned something of fortitude, and something of knowledge, and something of self-control, and this all reminds us of the next quality the Apostle mentions when he says, "Superadd to your self-control, patience." Dear friends, how absolutely necessary it is to be patient in the Lord's service, and in the accomplishment of the Lord's will? Here we are taking up various needles, and putting in different threads, putting in one a little ways, then dropping it and picking up another one, and then dropping that, and picking up another one, and then bringing in the first one again, and putting that in a little way and dropping it and bringing in another one, and so on, and finally we might come to the conclusion, "What is the use of all of this? How tiresome the whole thing is! It keeps me busy all the time looking after all of these particular threads, and sometimes I put one in and when I have it worked in to my satisfaction, I find it does not fit in with the pattern, and I have to pull out the whole thread again. I have made some serious mistake, and I will throw the whole thing away." Now, dear friends, if we have in some terrible moment of self-commiseration thrown the whole thing away, we have lost our patience and we have lost the opportunity of becoming sharers with our Lord in the precious privileges of His kingdom. Dear friends, the Lord never excoriates us for making mistakes; he never condemns us because we put the thread in the wrong way, but the Lord does expect that we shall learn patience in such degree that we will be willing to patiently pull the thread out and put it in again in the right way. If we do that, God's grace will be with us to strengthen us in our endeavors, and we shall have His assistance until we shall have finished the great work laid on us, until our garment is complete, and we are ready for a share with Him in the Bridal position.

We have not done with it all, dear friends, if we have learned about patience; that is simply the middle quality. We realize the necessity of keeping on while we are learning the lesson of dropping and picking up again these various threads. The Apostle says, "Superadd to your patience, godliness," or, to break it up into its old English expression, God-like-ness. Just think,

the Apostle says God expects us to be like Him! Is it possible? Is there any way for such poor, weak, creatures, members of the degraded human race, to develop qualities that would be in harmony with God's grand nature? Yes, dear friends, it is not only possible, but we are under a definite obligation to that end. Connect two passages of Scripture together and you will easily see the situation by the Apostle Paul. In Romans 8:29, he says: "For whom He did foreknow, He also did predestinate to be conformed to the image of His Son." Here the Apostle suggests that the Lord's people are under an obligation, that they are predestinated to be conformed to the image of Jesus Christ, our glorious Lord; but as the Church is looking to Jesus Christ, and setting her affections on Him, she is gradually developing characteristics that are like Himself. And then when we want to find what Jesus Christ is like, we turn to the third chapter of the Hebrews, the first three verses, and we have a statement clearly made that Jesus Christ was the express image of the Father's Person. Peter puts it in one word, Godlikeness, -- which is the obligation upon us. What is Godlikeness? We might elaborate it all afternoon, dear friends, and we would never get to the end of it. But very briefly it would be comprehended in the four special characteristics which God presents to us, -- justice, wisdom, love and power! These are the qualities God expects us to duplicate in our hearts, to bring into our golden-threaded ornamentation, to make it ready for the grand association with Him in His kingdom: justice to God, realizing that we have an obligation to God, that we be just in performing it, and not permit ourselves to be deflected by any consideration of selfishness, or self-will, in fulfilling the Lord's good purpose respecting us. To be just towards our fellowmen, to realize that we have certain obligations which must be performed in our conduct with one another day by day. To be just to the brethren when we consider their weaknesses and imperfections, not to deal with them from the standpoint of iron-handed tyranny, but recognizing our obligation of justice in such a degree that we will perform reasonably, and properly, and faithfully, all of our duties toward them, striving earnestly to conform ourselves to this feature of God's character, so that we might be helpful, and not be putting stumbling-blocks in other people's way.

I have noticed sometimes in our bearing with one another, we are inclined to put the order the other way and to say, "Brother Smith did not treat me just right; I do not think he is acting just right." That is not the position we are to take at all. If we are going to be just from God's standpoint, we are going to ask ourselves, Am I just to Brother Smith? When we come to consider the relationship of Brother Smith to ourselves, then we are to say, I am to manifest the spirit of love when I consider Brother Smith's actions toward me, and to show forth my loving consideration for his imperfections and weaknesses, because I know he, like myself, is deficient in various ways, and that he needs the loving consideration of the brethren. Now that is developing the particular quality of Godlikeness that the Lord wants to see in us.

And we are to have the quality of wisdom which comes down from above, the wisdom which is first pure, then peaceable, gentle, easy of entreatment, full of mercy and of good fruit; the wisdom of which Jesus speaks when He says that we are to be as wise as serpents and as harmless as doves; the wisdom to which the apostle Paul referred when he wrote to Timothy about the spirit of a sound mind, the wisdom which is to govern all of the Lord's people, the heavenly wisdom governing all of our thoughts and purposes, so that we will be striving to be wise and attentive to the interests of righteousness in our conduct with one another, and not so overly enthusiastic that we transgress the proper bounds in our endeavors to try to do good to one

another, and to the world in general, as we have opportunity. This is wisdom from the Lord's standpoint.

And then when we have learned something about wisdom, we have also learned something about the love which the Lord wants us to develop, a loving consideration for one another, a loving helpfulness that will try to provide for one another's interests, according to our best ability, a love that will permeate our thoughts and actions before one another, so that, striving to manifest the qualities of love, we shall be like God to the fullest extent possible.

We will realize also, while we are developing these qualities, that if we are trusting in the Lord, we shall have the power which will enable us to fulfill the requirements. "Be strong in the Lord and in the power of His might" is the exhortation of the Apostle, and if then we have the strength which the Lord provides, His powerful truth working in us will cement these four qualities and make one glorious fourfold thread of beauty with all its golden richness worked into this precious garment which God has given to us to manifest forth to His praise and honor, when we have reached the grandeur of the kingdom, and the Lord is willing to count us as glorious in His presence.

But when we have learned something about Godlikeness, the Apostle does not stop there, but says, "Superadd to godliness, brotherly kindness." Or, as more accurately translated in the Diaglott, and also in the revised version, "Love of the brethren." Superadd to your Godlikeness, love of the brethren. It does not stop with loving God, and loving Christ, and trying to fulfill the characteristics that are perfectly represented in them, but to let your love flow out in all that increasing intensity as you come to develop in the characteristics of righteousness, so that you will have loving kindness for all the Lord's people, realizing that we are all walking in the same way, striving to attain to the same conditions, having the same obligations before us, and wanting to be sources of assistance and encouragement to all with whom we come in contact who have named the name of Christ. We want to realize everything suggested by Solomon when he tells us, "There is that scattered, and, yet increaseth; and there is that withhold more than is meet, but it tendeth to poverty." We might sometimes in the deficiency of our knowledge of the requirements of the Lord's people be inclined to say, "It is not for me to attend to this matter personally, and not to take any particular notice of what anybody else is going to do, to just push myself ahead with all the earnestness I possess, and get there." But, dear friends, there is a spirit of selfishness about that attitude which is not in harmony with love of the brethren. The scattering of our loving interest toward others with whom we come in contact is the very thing which will enable us to make a greater amount of progress ourselves, and the withholding of more than is meet to ourselves, and preventing our loving thoughts and interests going out to others, will be the very thing that will tend to our spiritual poverty, and prevent us from a development of the righteous qualities that the Lord would approve. Love of the brethren is the love to which the Apostle refers in the 6th chapter of Galatians, 1st verse, where he says, "Brethren, if a man be overtaken in a fault, ye which are spiritual, restore such an one in the spirit of meekness, considering thyself lest thou also be tempted." It is the spirit of loving kindness which lifts up the erring brother who has fallen by reason of some overcoming thing in his flesh, setting him on his feet again to walk in the same narrow way, and to accomplish the same conditions as are laid upon us; it is that interest which, prompting us to the encouragement of another, will lead us to the sacrificing of our personal interests, so that we will show our

loving care for one another as fully and completely as it is possible for us to do in this present time of deficiency and weakness; and when we are doing that, this precious quality, the bright-shining characteristic of love of the brethren, is being drawn into its proper position, and worked in together with the other qualities to produce the ornamentation the Lord wants to see.

And then, dear friends, when we have learned what it is to love the brethren, and we have learned how to be charitable and considerate of the Lord's people with whom we come in contact, then the Apostle puts the climax to the whole situation. He speaks of the final quality which shall crown the entire ornamentation: "Superadd to your love of the brethren, love." That is all, dear friends, -- no limitation, no circumscribing of the expression by adding any adjectives to it to limit what it would express in comprehensiveness, but just love in all the grandeur of its fullness and completeness, flowing out to the whole world of mankind; not merely a general, compassionate, interest in the world as a whole, but going to so complete an extent that love for the very enemies who would injure us if they could, would be especially prominent in this characteristic. Dear friends, if we have that attitude in our hearts we will be able to fulfill that precious little thought which our dear Brother Barton left with some of us when he said, "Doing a kindness, being solicitous for one who has done us an injury, with a sincere tear in our eyes, is loving God." And it is more than loving God, it is loving as God loves, and that is what we want to do, because the Apostle John says in that precious text which we all realize so fully since we have learned about Present Truth, "God so loved the world that He gave His only begotten Son, that whosoever believeth on Him should not perish but have everlasting life." And, dear friends, that love manifested in our heart, welling up in our minds, and overflowing in our daily actions, doing good unto all men as we have opportunity, especially to the household of faith, is bringing into our garments such a precious golden thread that it is completing the arrangements the Lord requires; and when in the Lord's arrangement we have been permitted to so some little insignificant bit in showing our love for the world in the present time, God is going to take us to His glorious self to be associated with Him in His eternal kingdom with the grand Redeemer and Lord, the glorious Bridegroom, at our side. So in all the authority and power that that kingdom represents, these that have sought to love as God loves will be able to pour out their love without the possibility of any restraint upon every member of the human race, comforting, blessing, lifting up and helping them back to all the grandeur of Adamic perfection, because they learned to love in the present time. And thus they will be able to do the work which love would prompt in the glorious future. This is what God expects us to develop, dear friends. Is it any wonder it is proper to say that if we pay attention to these obligations there will not be time to do anything else? Thank God that though our time will be absolutely occupied in developing these characteristics from this standpoint, when we have gotten to the kingdom our work will not be finished, but it will be just begun to be manifested in all its grand completeness toward the whole world of mankind.

So, dear friends, as the Apostle has expressed it in the passage which we have called to your attention, -- if we have hearkened to the voice that has called us to leave our own country and our father's house, if we have made this full covenant of consecration to the Lord, and if we have been striving to develop these qualities that are pleasing in His sight, so shall the King greatly desire thy beauty. He is looking forward to it all; He sees the consummation, He perceives the wonderful development which this class can make if they put their trust and confidence in Him; and His mind pictures this grand company, perfectly formed in character and ready for

association in His kingdom, when they have been separated from their imperfect bodies of flesh of the present time, and He ardently longs to be associated with His Bride that she might manifest these characteristics in their beauty and glory in the heavenly estate, and He is waiting for that grand time to come when the work which He and His Bride shall perform may be inaugurated for the blessing and comfort of the race of mankind.

Dear friends, let us unite in earnest and prayerful desire to accomplish that which the Lord has given us to do, realizing that He who has begun a good work in us is perfectly able to complete it, unto the day of Jesus Christ; and if we are not sharers in that glorious position, it is because of our own error, our own mistakes, our own neglect to lay proper hold upon the assistances which the Lord has graciously provided.

Those who make their covenant of consecration to become members of the Bridal class, according to the Scriptures, are eventually divided into two different parts; one of them is the class which, realizing its obligations, went on day by day to fulfill that which the Lord gave it to do. These made mistakes, they slipped and fell in the way; from time to time they got their garments soiled with the flesh and with their contact with the ground, but just as soon as they realized they had made mistakes, then they immediately appealed to the Lord; they confessed their imperfections and weaknesses, and acknowledged with sorrow the wrong that had been done, and the Lord graciously washed out the stain and made the garment pure and white, so that the individual could see the lines or marking of the ornamentation which was to be properly worked in. But the other class forgot its obligations, forgot that which was laid upon them as necessary in order to be members of the Bride Class; when they fell, and allowed the cares of this world, and the deceitfulness of various kinds of riches to deflect their minds and to absorb their thoughts, and when they got spots on their garments, they did not go to the Lord, they did not ask Him for any assistance, they allowed the matter to accumulate. So they went further and they fell again, another spot got on the robe; and they went further and fell again, and got another spot on the robe, and so spot after spot has been accumulating on the robe, and after a time the lines which marked out the proper place to work in the ornamentation became obliterated, and it has been impossible for them to complete the work, and they are never going to get the place in the kingdom which the Lord promises to those who prove faithful. But because they are still wearing the robe, the Lord is going to give them a place, but it is going to be the place suggested in the part of the text we read which says, "The virgins her companions that follow her shall be brought unto thee." They are not of the queen class, they are the virgins who constitute bridesmaids, because they failed to appreciate their precious privileges.

And just at the risk of detaining you for a moment or two longer, I would like to call your attention to the description of this class in the 7th chapter of Revelation, 9th verse: "After this I behold, and, lo, a great multitude which no man could number, of all nations, and kindreds and people, and tongues, stood before the throne, and before the Lamb clothed with white robes and palms in their hands." Here it is described that a class said to be a great multitude which no man could number stood before the throne. There is a somewhat imperfect translation here, because the whole world of humanity could be numbered by anyone if he chose to take the time, and it has been done repeatedly, but what the proper translation suggests is, a number which no man knows; a number which God never revealed, because He never intended it to be a specified number, as He has determined the Church to be. But these, partially failing, kept their robes on

them, and the Lord will permit them to enter into the kingdom, and they shall have an opportunity to stand before the throne and bear palms in their hands; and then he goes on further to describe in the 13th and 14th verses: "And one of the Elders answered saying unto me, what are these which are arrayed in white robes? And whence came they? And I said unto him, Sir, thou knowest. And he said to me, these came out of great tribulation and have washed their robes, and made them white in the blood of the Lamb." Here is emphasized the fact that these accumulated spottings which they allowed to get on their garments while they were neglectful will be washed off, but because they did not do it while they had the opportunity of going on each occasion to the Lord and asking that the spot might be removed, because they allowed the accumulation to remain there, they must go through a severe trouble and there get all of this accumulation and soiling removed that they might again be clean. And when they come down to that experience, it will mean, dear friends, that the time has passed for them to develop their characters. They have gotten their robes clean, but they have not the time to put in the golden threads of character. In great tribulations, in severe fiery tests, they will have such strenuous experiences that in the heat of that time they will develop the right characters; but it will not be the slow, careful, meditative development which is represented in the bringing in of the golden threads, and working them into the garment so that they become specially beautiful as a golden ornamentation for a wedding-robe. It will be a character developed in the intensity of heat, in a short period of time, and therefore not to be specially honored by admitting the individual to a share in the kingdom. And when they have thus gotten rid of the manifestations of weakness and imperfection, and have been thoroughly reconciled to the Lord again, it is declared, "Therefore are they before the throne of God, and serve Him day and night in His temple, and He that sitteth on the throne shall dwell amongst them."

Now notice the distinction. The Queen sits on the throne, while this class stands before the throne. The Queen wears a crown, manifesting the fact that she is exalted to be on an equality with her Lord as a co-ruler, while this class does not wear any crown but simply holds palm branches while they stand before the throne. The Queen sits as ruler as she directs the various interests of the government, but while this other class stands before the throne, they do not rule; they serve God in His temple day and night forever. They are servants of the Temple, the Church, the specially blessed, the Bride of Christ, and they will continue in that position all through all the aeons of eternity, occupying a subordinate place, because they did not appreciate the precious privilege of making their calling and elections sure to the superior position when they had the opportunity.

God has not called us to this class; He has called none to share in this position of subordination; He has arranged it as a sort of consolation for those who maintain their faith while neglecting their responsibilities to some extent, and yet not to so great a degree as to merit the second death, and so He will give them the position of servants. He has called us with this precious exhortation suggested in our text, and He has set before us the glorious attractiveness of the situation, and He has suggested that He earnestly desires the beauty of these spiritually developed ones, and He leaves it to us to make our calling and election sure.

Dear friends, let us lay aside every weight, and the sin that doth so easily beset us, and let us look for grace and strength to Him who called us, being perfectly sure, according to His precious promise, that He who has begun a good work in us will never leave it until He shall have



gloriously completed it in the day of Jesus Christ, that we might honor Him in His kingdom by showing our faithfulness to the end, cooperating with Him in the establishment of His great work upon the earth. Amen.

**7:30 P.M. - Symposium**  
**on the "Fruits of the Spirit of Love"**  
*-- Love Feast following.*

**Bros. Thornton, Hall, Kuesthart, Rutherford, Williamson**



Bro. Thornton.      Bro. Hall      Bro. Kuesthart.      Bro. Rutherford.      Bro. Williamson

**Brother Williamson:** We have reached the last session of this glorious convention and are about to start out into the world as ambassadors for Christ, and we want to realize that we have learned something more about the old, old story of God's love. How refreshing it has been to our hearts, and we want to carry the refreshment to other hearts. Let us sing No. 116 -- "I love to tell the story of gracious heavenly love." This was followed by prayer by Bro. Frank Draper.

**Bro. Williamson:** We all feel like Peter did on the Mount of Transfiguration, we would like to build tabernacles and stay here with the Lord. The inspired record, however, says that Peter did not realize what he was saying. God has work for us to do and we cannot do it here. How He has blessed us! We have been in one place with one accord and we have gotten what we came for and now the Lord expects us to scatter to our different localities and pour out the blessings upon others, and so we must be on our way.

We are further reminded of the fact that while we must separate to the various responsibilities at our homes, we expect to meet by and by in the Great Convention, and we rejoice when we realize that it will never end. We will now sing No. 66, "Sweet By and By."

---

**Brother Williamson:** The first part of this evening's program is a Symposium, and our subject is one that must be of vital interest to everyone that is seeking to be prepared for the Kingdom of Heaven: "The Fruits of the Spirit."

The Apostle Paul in the fifth chapter of his epistle to the Galatians, the 22nd and 23rd verses tells us: "The fruits of the spirit are love, joy, peace, long-suffering, gentleness, goodness, faith, meekness, temperance, against such there is no law."

The Apostle declares that the spiritual condition which God wants to see in every consecrated child is the development of the fruits of the spirit. We might select one of these and talk all the evening upon that theme, and then we would be able to continue our convention for nine more sessions, because there are nine phases of the fruits that the Lord wants every Christian to develop. We have not nine sessions and we are at the end of this one, so we can say just about half a dozen sentences in connection with each one. Our dear brethren on the platform are going to tell just a little bit on these special features.

**Brother Hall**, who has been one of the faithful co-laborers in the Pilgrim service and active in other ways, and now with the Louisville (Ky.) Church, will give some suggestions in ten minutes on the first two fruits the Apostle mentions:

### **Love and Joy.**

Dear Friends: I would call your attention to the contrast in mentioning the fruits of the Spirit by Peter in the first chapter of his second epistle, and our symposium text for this evening, Gal. 5:22, 23, which reads: "The fruit of the spirit is love, joy, peace, long-suffering, gentleness, goodness, faith, meekness, temperance: against such there is no law." Peter is showing the construction of the "new creature" character, which our dear Bro. Williamson so forcefully presented this afternoon, while the Apostle Paul is evidently showing us the completion of this character. He describes it as the fruit of the spirit, the result or finished work of God working in us to will and to do of His good pleasure. This thought is emphasized by the Apostle in verses 19-21, where he says, "The works of the flesh are manifest, which are these: Adultery, fornication, uncleanness, lasciviousness (these four evils head the list in the depraved character even as love joy, peace, head the list in the perfect character), idolatry, witchcraft, hatred, variance, emulations, wrath, strife, seditions, heresies, envying, murders, drunkenness, revellings and such like and they which do (or practice) such things shall not inherit the Kingdom of God."

A fearful picture, is it not, dear friends. The Apostle holds up the lovable and the unlovable characters in antithesis for our consideration.

This love character of the new creature has been created in righteousness and true holiness by God "who hath saved us, and called us with an holy calling not according to our works, but according to His own purpose and grace which was given us in Christ Jesus." Now, what was this purpose? Surely not our salvation only. Dear friends, I fear we do not even yet always remember and understand the highest sense in which we are to be grateful to our gracious Heavenly Father for this wondrous salvation. We find the key in 1 Peter 2:9. Notice here the reason for our calling. Ye are a chosen generation, royal priesthood, a holy nation, a peculiar people that ye should show forth the praises of Him who hath called you out of darkness into His marvelous light." Dear friends, it is God's purpose that all His creation should show forth His praises. "The heavens declare the glory of God. Day unto day uttered speech and night unto night showed knowledge. There is no speech nor knowledge where their voice is not heard." This

sentiment in us of showing forth God's praises and never our own, is love -- love in its very highest sense. This principle is illustrated in our love for the brethren just as it is in loving, praising and admiring all of God's perfect work. True love for God with all our being is to shrink out of sight ourselves and pass on the praise to Him, for all we have and are is of Him that no flesh or being in any sphere may glory in themselves in His sight.

This new creature character reminds me of an art glass window I used to see and admire at the corner of Washington and Illinois streets in Indianapolis. It represented a beautiful girl just budding into womanhood, full of grace and innocence. You all know how such an art glass window is constructed; first the frame work of delicate metal, then the details of the figure worked out and the high lights and shadows of tinted glass set in their proper place. Thus gradually the artist produces a marvel of beauty. I thought how the delicate frame work that separates each tint in the picture fitly represents our faith structure, how as each new tint or glory is added, a cement is applied to keep the glass in position, showing the strengthening of our faith day by day as the Great Artist is "working in us to will and to do of His good pleasure."

This window faced the east. When the morning sun shown upon it no picture was discernible to those outside, but those in the room, which could represent the first apartment of the tabernacle, saw the glory and beauty of each tint as the sun of righteousness caused its light to be reflected in all its splendor on those inside. Again, when the electric lights inside illuminated the figure those out in the darkness of this world saw its glorious beauty, reminding me of the Lord's injunction to let my light so shine that men might see my good works -- the fruit of the spirit and glorify God. The second division of this fruit assigned to me is joy, which has been described as "love in exaltation." Dear friends, we have the joy of the gospel ever with us according to the measure of the spirit, or the capacity we possess of containing the spirit. We notice here at the convention, dear friends, how everybody is bubbling over with joy and gladness of heart in proportion as they are making others happy. We can only have the real joy when we are in service showing forth God's praises. For this reason those who are most active in service grow in grace and in favor with the Lord, because their continual joy of service enlarges their capacity by a rapid growth in the addition of the graces of the spirit until they come in the unity of the faith and of the knowledge of the Son of God unto a perfect man (the completion of the character picture) unto the measure of the stature of the fullness of Christ \* \* \* henceforth no more children tossed to and fro and carried about with every wind of doctrine."

The fullness of joy can only come to us when, clothed with majesty and power from on high as kings and priests we shall in the age to come lift up a dead world, turning their eyes to God their Savior, thus showing forth the praises of Him that called us out of darkness into His marvelous light.

Dear friends, we do not always show forth the praises of Him because of our many weaknesses, while in the flesh, but when the change shall come to us in the first resurrection, then, and in the ages to come it will not only be glory for me and for you to look on His face, but to continue to show forth His praises to all eternity. Then shall we have fullness of joy. If our hearts burn within us now and we overflow with joy whenever a hearing ear is found, their heart turning to God, hungry and starved, what shall the age to come have in store for us as we see the world coming back to righteousness, to the Garden of Eden, to God! Then indeed shall our joy be

complete. We are told to look unto Jesus the author and finisher of our faith, who for the joy that was set before Him, endured the cross, despising the shame. Was this not the joy of leading a ruined race back to God by showing forth the praises of the God who so loved the world that He could give His only begotten Son as a ransom for them that they might not perish, but through Him get eternal life?

So we see that the feeble words we may now use is not the fullest opportunity we shall have in showing forth his praises. Our actions sometimes speak far louder. Many of the Lord's people should now be at the mark for the prize and indeed should have recognized the principles of the fruits of the spirit early in their consecrated life. While we may have reached having done all we are to stand and let patience have her perfect work. It is only another way of saying the mark already -- many of us -- we remember that after the wheat has been ground into flour and formed into the one loaf it must be baked with fire before it can be broken to the world. Jesus' persecutions came while he was at the mark. He was born on it. Our severest trials shall be after we reach the mark also, so let us joy in tribulation and examine ourselves daily to see if we have yet learned to love and pray for those who hate us and despitefully use us. This is proof that we have the love of God shed abroad in our hearts, and the rejoicing in tribulation gives us confidence that we are nearing the glad day when our joy shall be full to overflowing, when we shall have been made into the image of God's dear Son.

**Brother Williamson:** I was raised, as far as my secular experience was concerned, in the law, and I was never impressed that many lawyers would get into the Kingdom. I now have the pleasure of introducing one whom the law did not take the desire from to serve the Lord with all his heart, our dear Brother Rutherford, who has been associated with the earthly law, but now associated with the heavenly law, and it will not be long before he will be regularly engaged in the Pilgrim work, as he has been partly. Brother Rutherford will now speak for ten minutes on

### **Peace and Long-Suffering.**

**Brother J. F. Rutherford, Boonville, Mo.:** We have reached the close of the most spiritual convention it has ever been my privilege to attend. We are also reminded of the fact that we are nearing the close of the harvest period, and also that we are one day nearer to the Kingdom, and as we reach this point along our life's course, we take a keen interest in all things concerning spiritual development. If there ever was a time, dear brethren, that there was a thought in our minds concerning the time features of God's plan, we ought to be able to judge today from the extraneous evidences about us that the time for the glorification of the Saints is at hand. Why? Because, dear friends, of the wonderful manifestations of love that we see among the dear friends here. We might say that we are practically led by sight while here at this convention. There never has been a time when the love of Jesus Christ for His Bride, so beautifully pictured in the Song of Solomon, or so clearly understood at the present time. And why so? Because the light of the Master is shining in our faces, clearly revealing God's plan, and causing us to realize more fully what Christ Jesus' love is for us. Thank God, dear friends, for the wonderful manifestations of love in taking out of the world a people for His name, the Bride, the members of His body -- called to be Saints. What is the purpose? "The saints shall judge the world."

Now, one of the qualities of a judge is peace, because no earthly judge can sit upon a court and do his duty unless he is peaceable, and no one will be able to judge the world unless he is peaceable and possesses that quality, because he will be called upon to sit with the Chief Justice and lead the turbulent elements of the world.

Another element is patient endurance with the short-comings of those being judged. These judges are now being taken out of the world, and the election will soon be over. For this reason, each one expecting to be elected as a judge must demonstrate the qualifications for the office, and one of these qualifications is peace, and another is long-suffering. Now then, dear friends, if we expect to occupy this position with our dear Lord and Master, are we striving day by day to develop in character these qualities? He has not called us without giving us an opportunity to develop those qualifications. He sends some out to preach by word of mouth; some by distributing the Dawns, etc. For what purpose? In order that those engaged in that work may come into contact with the various characters they are to judge.

One word for the encouragement of the dear Colporteurs; there is no part of the work that affords a more wonderful opportunity to study the weaknesses of human character than those have who are engaged in that work of colportering the Dawns, because every time you go to a door, you come into contact with a different character. I thank God that He has given us an opportunity to engage in the work.

Peace has been defined as, love in repose. There is not a more beautiful figure, to our minds from an earthly standpoint than a babe in its loving mother's arms, and, as it lies there looking up into its mother's arms, it may be said to be, at peace in love. Dear friends, if we are seeking to develop those fruits, we are peacefully in repose in Jesus' arms.

Peace has also been defined as love enduring. This is a peculiar combination of these two elements. If we are resting in that peace of God which passeth all understanding, we are at the same time longing to be with our Lord and Master beyond the veil, yet we are perfectly willing to stay here and suffer whatever the Lord may see necessary for us in order to develop the character-likeness of our master. While in repose peacefully in the arms of Jesus, we are suffering long in this world, desiring to be with our Father, desiring to be where we belong.

A dear brother said today, we are almost walking by sight. Another said, yes, and I wish I could go home from this convention. I believe every consecrated child of God would be glad if he could go home to his Master tonight, but we are not complaining if it is the Lord's will that we should suffer: His will be done. And we are rejoicing in long-suffering and we are bowing to His will.

If we are cultivating these two characteristics, these two elements of love, peace and long-suffering, we are preparing to go home to our Lord and Master. Let us all remember each other, not only tonight but at the close of each day, until the last member passes over.

God bless each and every one of you, and I extend to each one of you my heartfelt love.

**Bro. Williamson:** The next speaker, Brother Thornton, according to the flesh, is a Doctor of Medicine, but he is striving to understand something of the Spiritual ailments and to minister according to the spiritual requirements; we will now ask him to address us on the subject,

### **Gentleness and Goodness.**

**Bro. D. H. Thornton, of Athens, W. Va.:** My dear brethren, in appearing before you this evening in the name of my blessed Master, I do not wish you to have the thought that I do so because of my ability or that I wish to speak to you with enticing words of man's wisdom, but rather in plainness of speech; in order that the babes in Christ as well as those of more mature age may comprehend with all saints something of the heights and the depths and the lengths and the breadths of the goodness of God.

It is just like our dear Heavenly Father in dealing with His dear loving children to give them such seasons of refreshment and rejoicing together in gentleness and goodness as has been manifesting itself throughout the several days of this convention week.

Gentleness is love in society, while goodness is love in action. In other words, goodness is action; it is the active endeavor, whereas gentleness is the attitude or manner manifested in prosecuting this act. Goodness has an intrinsic value within itself, while gentleness is largely composed of a commercial value. To illustrate; gold would represent goodness, while a gold certificate would well represent gentleness. The certificate is very useful as a circulating medium, because it is very much more convenient to carry and to handle and even if worn out, may be renewed without having any loss of the merit of the gold itself. It is well illustrated in the golden thread mentioned by our Bro. Williamson in that most excellent discourse. Our Heavenly Father gave this to the Church and it was manifested in the bridal garments. That golden thread is goodness; it carries with it, all of its purity, even though we could not see it at all. Even though it were covered up the intrinsic merit and value remain there just the same. The adornment, the beautifying of the garment well represents gentleness. The ornamentation of the garment will shine forth on account of the presence of the thread itself.

To further illustrate: Goodness is like fruit, in that it possesses within itself nutritious properties that are well adapted to the perpetuation of physical life, whereas, gentleness is more like the beautiful effects of that fruit. The sweet aroma arising therefrom, is very much like you yourself; there is a beautiful appearance connected with each face before me of the dear brethren, and we believe there has been a sweet aroma; a sweet incense going up to the Lord from this people ever since we have been meeting here; throughout this convention. And His admonition is that we bear much fruit and so shall ye be disciples of the Blessed Master.

To further illustrate: Goodness is very much like the light that illumines the room we occupy this evening, whereas; gentleness is as the shining forth of this light. Goodness ought to light the room if it is not under a bushel, but put it under a bushel and you fail to receive the benefit therefrom, whereas, remove the bushel and let gentleness come in; let the light shine out and it will give its light to all in the room. It is said of the blessed Master Himself, He is the light of the world, He lights every man that cometh into the world. He said of us, that we are the light and we are admonished and we are to so let our light shine that others may see our good work and be

constrained to glorify our Father which is in Heaven. May you do this; may you so emulate the example of our great pattern the blessed Master in this respect -- letting our lights shine and shine and shine while here upon the earth; so that when translated from the shores of time to that Kingdom of righteousness where the sun of righteousness will ever prevail in all His Glory and Beauty that even over there, you may be bright and shining lights in the Kingdom of our Father and that you may ever dwell and be in the sunlight of God's eternal Glory.

And dear brethren, unto this end may each of you together with our ownself, develop these noble graces of the spirit -- gentleness and goodness.

**Bro. Williamson:** The next dear brother who shall speak to us was at one time associated with the Lutheran Denomination as a Minister of that particular sect of Babylon. We rejoice very much with him in connection with his relation to the truth and the trials experienced in the flesh, but which have developed much of the fruit in our dear brother. He will now address us in connection with,

### **Faith and Meekness.**

**Br. S. Kuesthart, Port Clinton, O.:** Two fruits of the spirit are, faith and meekness. These two Christian characteristics which our dear Bro. Paul calls the fruit of the Spirit we need and had to use to receive the truth; it was by faith that we accepted the truth. You will agree with me that only those of an understanding heart, of a meek and humble heart, have been enabled and blessed to receive the truth. Now, the fruit of the spirit which Paul called the manifestation of faith and meekness is it the same characteristic which we need and use when we receive the truth? Yes, it is. But it is in a much riper, more developed form; it is a fruit. And we know that to bring forth fruit, ripe fruit, it takes time. At first a little flower, very insignificant, and then a little fruit begins. It may be covered up by a leaf; it is invisible. As the rain from heaven, the water of truth falls down upon the fruit, it begins to grow. It has to be watered every day, and has also to remain on the tree from which it sprang forth, and that plant has to be fed and nourished. After a while, the fruit shows forth a little bit and begins to grow and it requires the sunshine of God's grace as well as the heat of the fiery trials to bring the color; to bring the ripeness of the fruit. And so our faith ought to grow. Did our faith grow? Yes indeed. While first we accepted the good tidings by faith, especially the central part of faith, that our Lord and Savior gave His life a Ransom for all and as I was included in the all, there was no doubt in my mind that I was one. I accepted it and was saved by the Grace of God. Being justified by faith freely from all things, faith was necessary again, faith to give everything to my Heavenly Father in Consecration. Faith was necessary and if we would continue in the narrow way, we must have faith; we find it is getting more difficult as we go on and maybe it is necessary to drop many things which we carried along at first; we have to drop them by the way-side one after another and rest exclusively on the everlasting Father and our dear Brother who is present. That is one thing we have to accept by faith and we know by faith beyond doubt that Christ is here the second time the Chief Reaper, to gather His saints the Elect, His Kingdom in full power in due time and that His dear Saints shall reign with Him.

Do we see any evidence of it? Only by faith dear friends, therefore;

"Trusting in Jesus I find sweetest rest,  
Just simply trusting Oh: how I am blessed."

Can we grow in humility? Yes indeed. Is it not something to be small and little? Yes indeed. In that direction we have to grow also. You remember Moses the meekest of all men; he had to become still more meek that the Lord might use him, and when in the right condition the Lord could use him as a great and mighty general and it was then that the Lord said to him, "Certainly I will be with thee." Think of our dear Lord who humbled Himself and became obedient even to the death of the cross. Just think of Him, how He humbled Himself and has been given a name above every name and if we are humble and meek, we shall be with Him in the same power and glory. Think of our Brother Paul, he was so glad that he had been permitted to become a sufferer for Christ's sake. We are glad that we have been able to humble ourselves and to be meek and little. It should be our daily prayer, "O To Be Nothing." Think of our dear brother who has been chosen by the Lord to dispense to the household the meat in due season at this time. He is certainly an example of meekness and humility. He does not claim anything for Himself of the truth brought forth but presents it to you and to me to accept or reject. I call your attention now of the necessity to develop the fruit of meekness. Whenever you see a fruit, you find that it is hanging down, bent down. If you see a head of ripe wheat it is bent down, only the tares stick their heads right up. Any precious fruit when ripe bends its head down. I know of only a few poisonous fruits that bear fruit with their heads up. We should have the spirit of meekness, the spirit of humility for faith and meekness go hand-in-hand, we have nothing of our own to offer. We are leaning on the everlasting arms of our Heavenly Father, we need faith every day. "All the way my Savior leads me." "The Father planned it all," and everything works for our good, the called ones according to His good Will.

Now dear friends, as we are nearing the end of this Gospel Age, as we have to make our calling and election sure, let us be faithful and let us remain meek and humble; it is the only safe-guard to stand and enter in.

Let us remember that we have nothing of our own but that it is all from our Heavenly Father; let us be faithful to the end and rely upon the everlasting arms of our dear Heavenly Father.

### **Temperance.**

**Brother A. E. Williamson:** The last quality of the fruits of the spirit is declared by the Apostle to be temperance. As we saw this afternoon, it does not signify temperance only in its restricted modern sense, but it does signify in the comprehensive sense, "self-control." It signifies all that the word Temperance in its usual meaning implies, when expressed in the language of the present day regarding moderation in the use of food and drink. We are not to forget that it has that application also. We are under just as much obligation when we are endeavoring to manifest the quality of self-control when we see that it applies to what we eat and drink, as to where we put our affections, as to how we use our time and what we do with our influence. If I consulted my appetite and eat all I can enjoy because my palate wants to be tickled, then I am not exercising self-control; I am living for the purpose of eating and drinking. A person who has made a consecration to the Lord has no right to live to eat and drink. He is not his own; he has been bought; he belongs to another, and as he is a member of the body of Christ our Lord, he is



under a sacred obligation to eat and drink so that he might use his body for the glorification of God. If I realize that in attending to that duty of the physical requirements, that I have certain obligations to perform, I will endeavor to make such wise selections in food for the sustenance of my body, and when making that selection, I am exercising self-control, when not, I am not exercising self-control, and I am bound to suffer. There is bound to be certain interference with my bodily functions and consequently with my usefulness in the Lord's service. By exercising self-control, I am endeavoring to round out the character the Lord expects me to have. But looking at self-control from a broader standpoint, I have often been very much strengthened by the illustration of Jesus, when he said, in Matthew 11:28-30, "Come unto Me, all ye that labor and are heavy laden, and I will give you rest. Take My yoke upon you and learn of me; for I am meek and lowly in heart; and ye shall find rest unto your soul. For My yoke is easy and My burden is light." In the first exhortation, He is willing to take the burden away from the individual and give him righteousness, peace, and liberty -- justification. Next, we are to take something, He says take My yoke upon you, put a new burden upon yourself, undertake a certain obligation; it is your privilege. We ought to show our appreciation. The object of the yoke was and is to harness two animals side by side in order that their united strength co-operated might fulfill a duty not otherwise so successfully performed. The two animals yoked up together, their strength properly divided, would be able to do a work if they appreciate their relation to one another. Supposing one was inclined to be obstreperous and wanted to get away; you can easily see that their relation would be a sorry one indeed. The yoke would be forced down upon them and would chafe each animal and there would be no comfort or satisfaction in their work. That is just the condition individuals get into who are yoked up with the Lord in consecration but are trying to fulfill their own wills, and they go back to the former condition. In so doing, they are either running away ahead of the Lord or getting behind Him; in either condition lacking self-control. Many are trying to get ahead of the Lord, thinking this is the time to save the world, thinking about something else than developing character. They see the world needs something but as they do not study the truth, they think the world needs their assistance to bring them in. They are losing the precious blessing the Lord ordained should be their portion now. He says, – "Learn of Me." While not learning of Him, they are experiencing the chafing of the yoke which prevents them from experiencing the peace and satisfaction they ought to enjoy. While that is not commendable, the other side of the matter is still less commendable; they drop away behind the Lord. Many are inclined to say, the Lord can get along without me; He has so many I may as well take things as they come. That is dropping a long way behind the Lord, not exercising self-control, and the Lord will not appreciate them and will not bless them. Our duty is to give the Lord all our hearts and serve Him, laying aside our wills and when doing just as the Lord instructs us we are exercising self-control. When we are moderate with all these matters, we are along side the Lord and then we can learn of Him, because we can see how He is walking and how He wishes us to fulfill His will, and we will be able to carry it out in all the details of life. If walking with Him day by day and learning the lesson of patience and experience the Lord wants us to learn, His yoke will be easy, His burden will be light. It will not bring trouble; it will bring comfort, peace and happiness and God's grace manifesting itself in the fact that Jesus Christ is the great burden bearer and that He is holding the largest portion upon His shoulder, and we will bear just enough to properly fulfill our duty, using all our strength in His service. We will get the rich blessing the Lord intends us to have and then we will be greater and grander servants in the Eternal Kingdom to which He is inviting those who have developed this precious fruit of the Spirit. I trust dear friends, that as we think of this precious fruit, we will desire to manifest all of

the fruits of the Spirit day by day, continuing in the way of righteousness and sacrifice and so make our calling and election sure, and eventually, according to the promise, be received into an abundant entrance into the Everlasting Kingdom of our Lord and Savior, Jesus Christ.

### Love Feast.

**Bro. Williamson:** Now dear friends, the time has come when we must separate; we have feasted together in Spiritual things; we have partaken of the great bounty that His grace has provided. We realize that the Lord has been good to us in permitting us to gather again, we know not what the circumstances may be under which we may gather under another occasion. Every period between conventions shows that the Lord is calling to Himself those whom He recognizes as having fulfilled their Consecration vows and are ready to be received Home. There certainly will be from this convention some, but we do not know how many. It may be myself; it may be each of you, dear friends. Think of it and realize what responsibility rests upon us. If we go by the Lord's grace, it will be into the glory of the Eternal Kingdom and all the pleasure of the Spiritual feasting even while they shall be waiting for the last member to come before the marriage supper can be accomplished. We must be ready. We are not to think of it as this experience has been thought of in the past, that we must be ready against a great day of reckoning in which the Lord was going to decide our eternal fate, either in heavenly bliss or torment of an eternal agonizing kind. We are to think of it from the standpoint of our consecration and having undertaken a certain work, it must be performed and He will give us the grace to carry it out and so live each day as though it were our last day until our Lord is pleased to say: "Well done, good and faithful servant, thou hast been faithful over a few things, I will make thee ruler over many things; enter thou into the joy of the Lord." We shall be able to rejoice in the rich refreshment that approving word may bring and experience a wonderful blessing with those beyond the veil. As has been suggested many times since I have arrived, the veil is very thin, we can almost see through it, so to speak, and realize that there are some who are exceedingly close to it and being called to be associated with those on the other side. Bro. Barton gave an illustration which greatly impressed me. It seems as though all the Lord's people were sitting down at the Lord's table, just 144,000 at that table, and there was a veil in certain place on the table which divided those who were in the Kingdom and feasting on the Spiritual things on that side, and those on this side feasting on the natural things, before they entered. And when the Lord was ready, He simply moved the veil one, two or three spaces as the conditions may be. And as the veil moves down, it would eventually take in the whole banquet table and all would be realizing the great banquet. There would be no change in the food. It is just simply a different condition under which we shall be eating. Let us rejoice in the Lord's favor in providing the precious food that is being given us now. We will feel that it is simply coming inside the veil and having the same blessings continued with us in a better condition as far as our bodies are concerned.

Then dear friends, we have some work to do and I believe we are all going to do it and the grace of the Lord will be provided for us so that we will not make any mistakes as far as the Lord's arrangements are concerned or our intentions. If we appreciate the situation, let us continue in the work realizing that He will be with us thoroughly and effectively. Let us so work before Him as to please Him and let us so trust Him that we shall not slip, and let us labor to see that when our work is finished here that it will be proper to say of us that we have ceased to labor but continue our work. It is so suggested in the 14th chapter of Revelation, 13th verse: "Blessed are

the dead which die in the Lord from henceforth; yea saith the Spirit, that they may rest from their labors, and their works do follow them." So while we now labor and recognize that the labor is laborious because of our weakness and imperfections, yet when we get into the Kingdom, we are not going to stop work; because the very object of being called to the Kingdom is to do the most glorious work God could give us to do. We are rejoicing in getting tired in the Lord's service and we thank God that His grace is sufficient, but we will never be tired of God's service, but will wait until the time when the laboring ceases and we will be able to engage in the precious work which will not be labor because of the bodies provided and the intentions of our minds will be able to fully express themselves. Let us give ourselves to this work so that in due time, we may be able to enter together beyond the veil.

---

At this point all of the Elders from the various congregations were requested to line up in front of the platform; then in front of them stood the brethren who had spoken at the different sessions of the convention, the Pilgrims holding plates of bread. Opposite to this line, was another very long line facing them, composed of the colporteurs and intending colporteurs. The congregation was then invited to pass between these two lines, which they did, shaking hands with them, wishing them God's blessing and breaking bread with the Pilgrims.

Thus ended the best convention ever held. Indianapolis was good, Niagara better, but Norfolk BEST.



*(We wish to again remind the friends that the Report has not been edited by the speakers but the discourses, except where condensed, are practically as delivered. If the speakers were to write out their discourses for publication, many phrases would doubtless be changed, but reporting them as delivered carries with the Report the personality of the speakers, and the friends can almost imagine they are in actual attendance.)*

## **JUDGE ME, O LORD! Psa. 26:1.**

I want the Father's favor, O, I wish His sweet "well done,"  
To crown this consecrated way in which my feet have run!  
It worries me but little as to what shall be the prize,  
But I long beyond describing for approval in His eyes.

It pains me when I find the world misunderstands my ways,  
And grieves still more to hear my friends unkindly voices raise.  
So Lord, to Thy wise judgment, my decision now I leave,  
In confidence 'twill be alright, whatever I receive.

I know if I must stand the test applied by earthly fame,  
Or fill the measure that is used by those who live for gain,  
Or even reach unto the mark which worldly minds call ease,  
All they will disappointed be who measure me by these.

And e'en disciples of my Lord who look for outward deeds,  
Will judge me wrong as they behold how many are my needs.  
They'll hear me speak the hasty word, they'll see my fault and sin,  
And lack the grace that is in Thee -- the power to look within.

How little knowledge do they have of how that thing I did,  
Was meant by me the other way, -- to their eyes that is hid.  
The thing so good I wished to do they never, never know,  
The motive in the heart's unseen, the weaknesses but show.

But even self cannot be judge of what I shall receive;  
My feelings, and my failings too, would even me deceive; --  
I may sometimes account myself more virtuous than right,  
Or even may condemn severe where censure should be light.

But Father, I can trust in Thee more than in self or friend!  
Just where I'm right, just where to blame, -- Thou canst all comprehend.  
Thou knowest what the heart has meant and where the flesh was weak,  
And in the secret of my soul, the motives Thou dost seek.

I fear not Thy correction, for I know 'twill be in love,  
Sent not to hurt and crush me, but to fit me for above.  
I try self-disciplining, but I leave so much undone; --  
To teach those needed lessons best Thou are the very One.

Oh! show me where I'm faulty and then show me what is right,  
And as I learn the lesson, give me strength the wrong to fight.  
My heart holds purest motives, in my life may they shine out;  
Thy holy spirit's presence proving thus to those about.

-- Selected.